

OPERATION MANUAL

VRV SYSTEM Inverter Air Conditioners

MODELS

4-Way Blow Ceiling-Suspended type

FXUQ18PAVJU

FXUQ24PAVJU

FXUQ30PAVJU

FXUQ36PAVJU

English

Français

Español

Read these instructions carefully before installation.
Keep this manual in a handy place for future reference.
This manual should be left with the equipment owner.

Lire soigneusement ces instructions avant l'installation.
Conserver ce manuel à portée de main pour référence ultérieure.
Ce manuel doit être donné au propriétaire de l'équipement.

Lea cuidadosamente estas instrucciones antes de instalar.
Guarde este manual en un lugar a mano para leer en caso de tener alguna duda.
Este manual debe permanecer con el propietario del equipo.

SAFETY CONSIDERATIONS

Read these *Safety Considerations for Operations* carefully before installing air conditioning equipment. After completing the installation, make sure that the unit operates properly during the startup operation. Instruct the customer on how to operate and maintain the unit.

Inform customers that they should store this Operation Manual with the Installation Manual for future reference.

Meanings of **DANGER**, **WARNING**, **CAUTION**, and **NOTE**

Symbols:

 **DANGER**.....Indicates an imminently hazardous situation which, if not avoided, will result in death or serious injury.

 **WARNING**.....Indicates a potentially hazardous situation which, if not avoided, could result in death or serious injury.

 **CAUTION**.....Indicates a potentially hazardous situation which, if not avoided, may result in minor or moderate injury. It may also be used to alert against unsafe practices.

 **NOTE**Indicates situations that may result in equipment or property-damage accidents only.

DANGER

- Do not install the unit in an area where flammable materials are present due to risk of explosion resulting in serious injury or death.
- Any abnormalities in the operation of the air conditioner such as smoke or fire could result in severe injury or death. Turn off the power and contact your dealer immediately.
- Refrigerant gas may produce toxic gas if it comes in contact with fire, such as from a fan, heater, stove, or cooking device. Exposure to this gas could cause severe injury or death.
- For refrigerant leakage, consult your dealer. Refrigerant gas is heavier than air and replaces oxygen. A massive leak could lead to oxygen depletion, especially in basements, and an asphyxiation hazard could occur leading to serious injury or death.
- If equipment utilizing a burner is used in the same room as the air conditioner, there is the danger of oxygen deficiency which could lead to an asphyxiation hazard resulting in serious injury or death. Be sure to ventilate the room sufficiently to avoid this hazard.
- Safely dispose of the packing materials. Packing materials, such as nails and other metal or wooden parts, may cause stabs or other injuries.
- Tear apart and throw away plastic packaging bags so that children can not play with them. Children playing with plastic bags face the danger of death by suffocation.

WARNING

- Contact your dealer for repair and maintenance. Improper repair and maintenance may result in water leakage, electric shock, and fire. Only use accessories made by Daikin that are specifically designed for use with the equipment and have them installed by a professional.
- Contact your dealer to move and reinstall the air conditioner. Incomplete installation may result in water leakage, electric shock, and fire.
- Never let the indoor unit or the remote controller get wet. Water can cause an electric shock or a fire.
- Never use flammable spray such as hair spray, lacquer, or paint near the unit. Flammable spray may cause a fire.
- When a fuse blows out, never replace it with one of incorrect ampere ratings or different wires.
- Never inspect or service the unit by yourself. Contact a qualified service person to perform this work.
- Turn off all electrical power before doing any maintenance to avoid the risk of serious electric shock; never sprinkle or spill water or liquids on the unit. Do not touch the switch with wet fingers. Touching a switch with wet fingers can cause electric shock.
- Do not allow children to play on or around the unit to prevent injury.
- The heat exchanger fins are sharp enough to cut. To avoid injury wear gloves or cover the fins while working around them.
- Do not put a finger or other objects into the air inlet or air outlet. The fan is rotating at high speed and may cause injury.
- Check the unit foundation for damage on a continuous basis, especially if it has been in use for a long time. If left in a damaged condition the unit may fall and cause injury.
- Placing a flower vase or other containers with water or other liquids on the unit could cause a shock or fire if a spill occurs.
- Do not touch the air outlet or horizontal blades while the swing flap is in operation because fingers could get caught and injured.
- Never touch the internal parts of the controller. Do not remove the control box cover because some parts inside are dangerous to touch. To check and adjust internal parts, contact your dealer.
- Be sure to ground the unit. Do not ground the unit to an utility pipe, arrester, or telephone ground. Incomplete grounding may cause electric shock, or fire. A high surge current from lightning or other sources may cause damage to the air conditioner.
- This equipment can be installed with a Ground-Fault Circuit Breaker (GFCI). Although this is a recognized measure for additional protection, with the grounding system in North America, a dedicated GFCI is not necessary.



CAUTION

- Do not use the air conditioner for any other purposes other than comfort cooling or heating. Do not use the unit for cooling precision instruments, food, plants, animals or works of art.
- Do not place items under the indoor unit as they may be damaged by condensates that may form if the humidity is above 80% or if the drain outlet gets blocked.
- Before cleaning, stop the operation of the unit by turning the power off or by pulling the supply cord out from its receptacle. Otherwise, an electric shock and injury may result.
- Do not wash the air conditioner with excessive water. An electric shock or fire may result.
- Avoid placing the controller in a spot splashed with water. Water entering the controller may cause an electric shock or damage the internal electronic parts.
- Do not operate the air conditioner when using a room fumigation type of insecticide. Failure to observe this could cause the chemicals to be deposited in the unit and can endanger the health of those who are hypersensitive to chemicals.
- Do not turn off the power immediately after stopping operation. Always wait for at least five minutes before turning off the power. Otherwise, water leakage may occur.
- This appliance is not intended for use by persons (including children) with reduced physical, sensory or mental capabilities, or lack of experience and knowledge, unless they have been given supervision or instruction concerning use of the appliance by a person responsible for their safety.
- The remote controller should be kept away from children so they cannot play with it.
- Consult with the installation contractor for cleaning.
- Incorrect cleaning of the inside of the air conditioner could make the plastics parts break and cause water leakage or electric shock.
- Do not touch the air inlet or aluminum fin of the air conditioner as they can cut and cause injury.
- Do not place objects in direct proximity of the outdoor unit. Do not let leaves and other debris accumulate around the unit. Leaves are a hotbed for small animals which can enter the unit. Once inside the unit, animals can cause the unit to malfunction, and cause smoke or fire when they make contact with electrical parts.



NOTE

- Never press the button of the remote controller with a hard, pointed object. The remote controller may be damaged.
- Never pull or twist the electric wire of the remote controller. It may cause the unit to malfunction.
- Do not place appliances that produce open flames in places that are exposed to the airflow of the unit or under the indoor unit. It may cause incomplete combustion or deformation of the unit due to the heat.
- Do not expose the controller to direct sunlight. The LCD display can become discolored and may fail to display the data.

- Do not wipe the controller operation panel with benzene, thinner, chemical dust cloth, etc. The panel may get discolored or the coating can peel off. If it is heavily dirty, soak a cloth in water-diluted neutral detergent, squeeze it well and wipe the panel clean. Then wipe it with another dry cloth.
- Dismantling of the unit, disposal of the refrigerant, oil, and additional parts, should be done in accordance with the relevant local, state, and national regulations.
- Operate the air conditioner in a sufficiently ventilated area and not surrounded by obstacles. Do not use the air conditioner in the following places.
 - a. Places with a mist of mineral oil, such as cutting oil.
 - b. Locations such as coastal areas where there is a lot of salt in the air.
 - c. Locations such as hot springs where there is a lot of sulfur in the air.
 - d. Locations such as factories where the power voltage varies a lot.
 - e. In cars, boats, and other vehicles.
 - f. Locations such as kitchens where oil may splatter or where there is steam in the air.
 - g. Locations where equipment produces electromagnetic waves.
 - h. Places with an acid or alkaline mist.
 - i. Places where fallen leaves can accumulate or where weeds can grow.
- Take snow protection measures. Contact your dealer for the details of snow protection measures, such as the use of a snow protection hood.
- Do not attempt to do electrical work or grounding work unless you are licensed to do so. Consult with your dealer for electrical work and grounding work.
- Pay attention to operating sound. Be sure to use the following places:
 - a. Places that can sufficiently withstand the weight of the air conditioner yet can suppress the operating sound and vibration of the air conditioner.
 - b. Places where warm air from the air outlet of the outdoor unit or the operating sound of the outdoor unit does not annoy neighbors.
- Make sure that there are no obstacles close to the outdoor unit. Obstacles close to the outdoor unit may drop the performance of the outdoor unit or increase the operating sound of the outdoor unit.
- Consult your dealer if the air conditioner in operation generates unusual noise.
- Make sure that the drainpipe is installed properly to drain water. If no water is discharged from the drainpipe while the air conditioner is in the cooling mode, the drainpipe may be clogged with dust or dirt and water leakage from the indoor unit may occur. Stop operating the air conditioner and contact your dealer.

CONTENTS

SAFETY CONSIDERATIONS.....[i] [ii]	
1. NAMES AND FUNCTIONS OF PARTS.....	1
2. MAINTENANCE (FOR SERVICE PERSONNEL)	1

1. NAMES AND FUNCTIONS OF PARTS

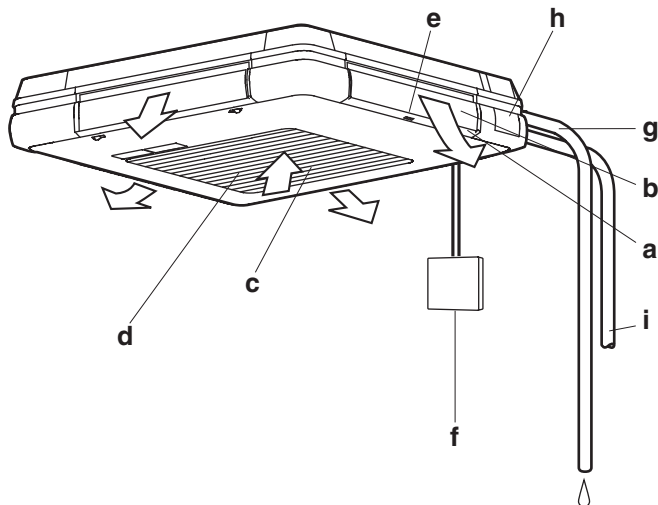

a	Air outlet
b	Horizontal blade (inside air outlet)
c	Suction grille (Refer to "2. MAINTENANCE")
d	Air filter (inside suction grille) (Refer to "2. MAINTENANCE")
e	Air outlet identification mark (□, □□, □□□, □□□□) Use this mark as a reference for setting the airflow direction.
f	Remote controller (optional accessory) The remote controller may not be needed depending on the system configuration.
g	Drain piping
h	Drain pump (built-in) It drains moisture in the room removed during the cooling operation.
i	Refrigerant piping Transmission wiring Power supply wiring Ground wiring (Note) (Note) Ground wiring allows electricity flow from the indoor unit to the ground for prevention of electric shocks or a fire in case of emergency.

2. MAINTENANCE (FOR SERVICE PERSONNEL)

ONLY A QUALIFIED SERVICE PERSON IS ALLOWED TO PERFORM MAINTENANCE

⚠ WARNING

- Do not use flammable gas (such as hair sprays and insecticides) near the air conditioner.
- Do not wipe the air conditioner with benzene or thinner. It may cause cracks, electric shocks or a fire.
- Never put your fingers or rods in the suction grille, air outlet or horizontal blade. The fan is rotating at high speed, so you would get injured.

⚠ CAUTION

- Do not wash the air conditioner with water. It may cause electric shocks or a fire due to leakage.
- Make sure to turn off the air conditioner when taking care of the air conditioner and disconnect the power supply breaker.
Unless the power supply is disconnected, it may cause electric shocks and injuries.

NOTE

- Do not remove the air filter except for cleaning. Operating the unit without an air filter may result in failure.
- Do not attach substances (such as paper towels) other than the specified air filter to the suction grille. The performance may drop and cause freeze-up/water leakage.

HOW TO CLEAN THE AIR FILTER

When the remote controller indicates a filter sign, clean the air filter.

- The sign is made after the system runs for a defined period of time.

NOTE

- You may change the time of indication a filter sign.
If the indoor unit is used in a space where the air is more contaminated, ask your local dealer for solution.

Dust level	Time until sign is displayed
Normal	2500 hours (equivalent to one year)
More contaminated	1250 hours (equivalent to a half year)

- If it becomes difficult to remove dust from the air filter, replace the air filter.
(The replacement air filter is an optional accessory.)

1. Open the suction grille.

Simultaneously and slowly slide the two knobs down the suction grille.

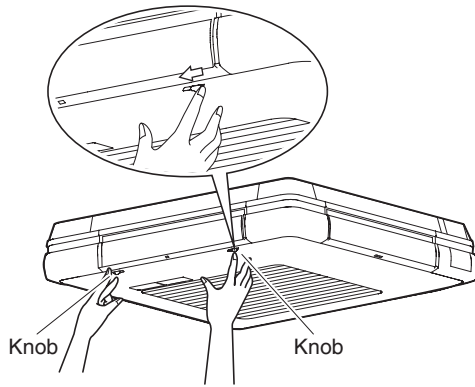

2. Take out the air filter.

Carry out the work in the order mentioned below.

- 1 Pull the air filter end inclined downward and unhook the hooking hole of the air filter from the projection of the grille. (both right and left)
- 2 Lift the air filter and unhook the hooking hole of the air filter from the projection at the grille upper part. (both left and right)

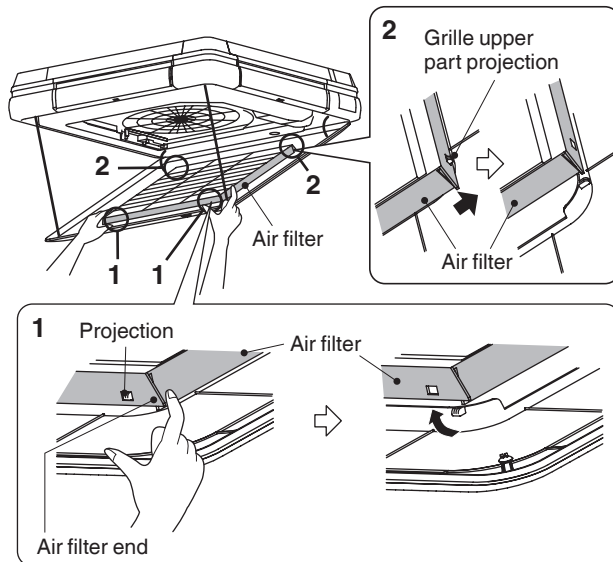

3. Clean the air filter.

Clean the dust with a vacuum cleaner or wash it with water.

If the air filter is extremely dusty, wash it with neutral detergent using a soft brush.



After dewatering, dry the air filter in the shade.

NOTE

- Do not wash the air filter with hot water of 122°F (50°C) or higher. It may cause decolorization and deformation.
- When drying the suction grille, do not heat it with fire. It may cause burning.
- Do not use chemicals such as gasoline, benzine, thinner, polishing powder and liquid insecticide sold in the market. It may cause discoloration and deformation.

4. Attach the air filter.

Attach the air filter in the reverse order mentioned in the step 2.

5. Close the suction grille.

Simultaneously slide the two knobs, slowly lift the suction grille and securely fix it in the reverse order mentioned in the step 1.

6. Reset the filter sign displayed on the remote controller after turning on the power supply.

- For details, refer to the operation manual attached to the remote controller. The sign can be turned off whether in operation or at stop.

NOTE

- When closing the suction grille, the strap is likely to be sandwiched. **Make sure the strap is not sticking out before closing the suction grille.**

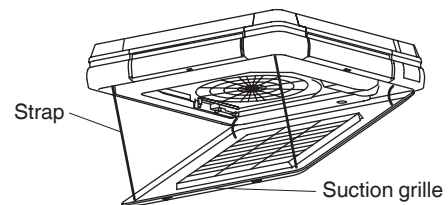

HOW TO CLEAN THE SUCTION GRILLE

1. Open the suction grille.

Simultaneously and slowly slide the two knobs down the suction grille.

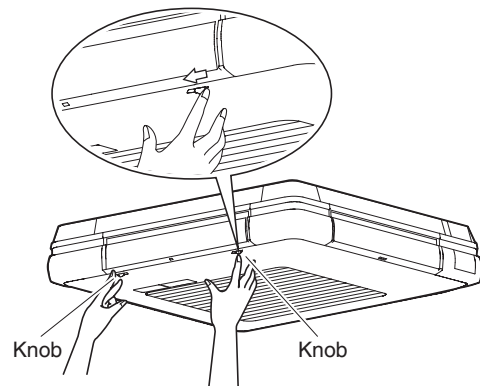

2. Remove the suction grille.

- 1 Remove the 4 straps attached to the indoor unit. (Refer to the figure shown below.)
- 2 Open the suction grille to 45° and lift it. Then, unhook it from the place to hook. (3 places)

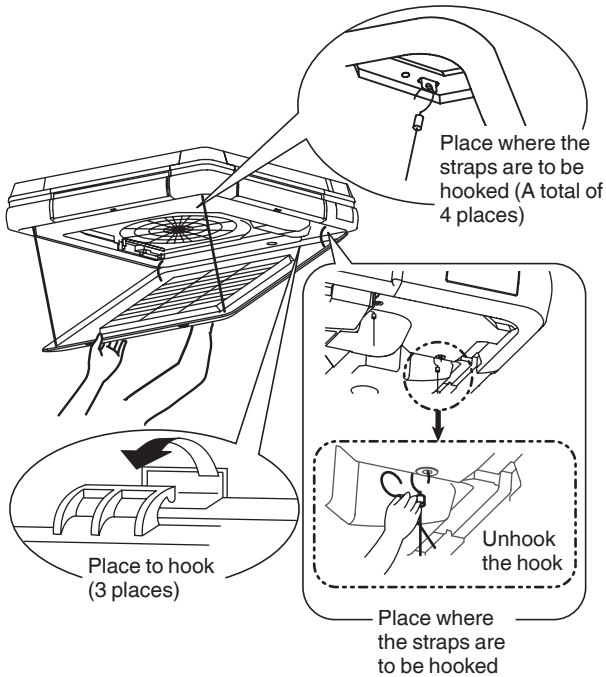

3. Take out the air filter.

Refer to the step 2 of "HOW TO CLEAN THE AIR FILTER". (page 2)

4. Clean the suction grille.

Wash the suction grille with neutral detergent using a soft brush and then dewater.

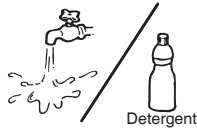

When the suction grille is extremely dusty

- Spray a detergent for a ventilating fans and ranges directly on to the suction grille, and allow it to penetrate for about 10 minutes.
- After that, carefully wash the suction grille with water.

NOTE

- **Do not wash the suction grille with hot water of 122°F (50°C) or higher.**
It may cause discoloration and deformation.
 - **When drying the suction grille, do not heat it with fire.**
It may cause burning.
 - **Do not use chemicals such as gasoline, benzene, thinner, polishing powder and liquid insecticide sold in the market.**
It may cause discoloration and deformation.
5. **Attach the air filter.**
Refer to the step 4 of "HOW TO CLEAN THE AIR FILTER". (page 2)
 6. **Attach the suction grille.**
Attach the suction grille in the reverse order mentioned in the step 2.

7. Close the suction grille.

Simultaneously slide the two knobs in the reverse order mentioned in the step 1, slowly lift the suction grille and securely fix it.

HOW TO CLEAN OUTSIDE PANELS AND REMOTE CONTROLLER

- Wipe them with a dry soft cloth.
- If the stain cannot be wiped off, dip the cloth in the neutral detergent diluted with water and twist the cloth.
After wiping off stain with this cloth, wipe them with dry cloth.

NOTE

- **Do not use chemicals such as gasoline, benzene, thinner, polishing powder and liquid insecticide sold in the market.**
It may cause discoloration and deformation.
- **Do not wash them with hot water of 122°F (50°C) or higher.**
It may cause discoloration and deformation.

■CLEANING BEFORE AND AFTER SEASONAL USE

WHAT TO DO WHEN STARTING UP AFTER A LONG PERIOD OF NO USE

Confirm the following.

- Check that the air inlet and outlet of indoor and outdoor unit are not blocked.
Remove any obstacle.
Obstacles decrease the fan speed, and cause performance decrease and may damage the unit.

Clean the air filter.

- After cleaning the air filter, make sure to reinstall it. (Refer to "2. MAINTENANCE" on page 1.)
For information on how to install, remove, or clean the optional air filter, refer to the installation manual attached to the air filter.
- Turn off the filter sign displayed on the remote controller after turning on the power.
- For details, refer to the operation manual attached to the remote controller.
The indication can be turned off whether in operation or at stop.

Turn on the power circuit breaker at least 6 hours before operation.

- This is required in order to activate the air conditioner smoothly, and to protect the air conditioner.
- The display on the remote controller will be shown when the power circuit breaker is turned on.

HEATING OPERATION within 6 hours after power is supplied to the air conditioner.

Some model series perform the following operation to protect the equipment.
If the HEATING OPERATION is performed within 6 hours after power is supplied to the air conditioner, the indoor fan stops for about 10 minutes during the outdoor unit operation to protect the equipment.

The above operation is performed not only for installation, but every time the power circuit breaker is turned off/on. For comfortable use, do not turn off the power circuit breaker during seasonal use of the HEATING OPERATION.

WHAT TO DO WHEN STOPPING THE AIR CONDITIONER FOR A LONG PERIOD

Turn on FAN OPERATION for a half day on a nice day and dry the indoor unit.

- This can prevent the causes of mold.

Turn off the power circuit breaker.

- When the power circuit breaker is on, some electricity is used even if the air conditioner is not operating. Turn off the power circuit breaker to save energy.
- When the power circuit breaker is off, there is no longer a display on the remote controller.

Clean the air filter.

- Be sure to reinstall the air filter after cleaning. (Refer to “**2. MAINTENANCE**” on page 1.) For information on how to install, remove, or clean the optional air filter, refer to the installation manual attached to the air filter.

NOTE

The inside of the air conditioner may become dusty after several seasons of use, potentially causing performance degradation and water leakage. Ask your local dealer for details on cleaning the inside of the indoor unit. This operation requires a qualified service person.

DAIKIN MANUFACTURING COMPANY, L.P

Daikin Texas Technology Park,
19001 Kermier Road,
Waller, TX, 77484, U.S.A.

