

DM80VC/DC80VC GAS FURNACE - CATEGORY I CATÉGORIE I

Table of Contents

These furnaces comply with requirements embodied in the American National Standard / National Standard of Canada ANSI Z21.47·CSA-2.3 Gas Fired Central Furnaces.



Intertek

*Installer:
Affix all manuals
Adjacent to the unit.*

! RECOGNIZE THIS SYMBOL AS A SAFETY PRECAUTION

*NOTE: Please contact your distributor or our website for the applicable Specification Sheet referred to in this manual.

! WARNING

ONLY PERSONNEL THAT HAVE BEEN TRAINED TO INSTALL, ADJUST, SERVICE, MAINTENANCE OR REPAIR (HEREINAFTER, "SERVICE") THE EQUIPMENT SPECIFIED THIS MANUAL SHOULD SERVICE THE EQUIPMENT.

THIS EQUIPMENT IS NOT INTENDED FOR USE BY PERSONS (INCLUDING CHILDREN) WITH REDUCED PHYSICAL, SENSORY OR MENTAL CAPACITIES, OR LACK OF EXPERIENCE AND KNOWLEDGE, UNLESS THEY HAVE BEEN GIVEN SUPERVISION OR INSTRUCTION CONCERNING USE OF THE APPLIANCE BY A PERSON RESPONSIBLE FOR THEIR SAFETY.

CHILDREN SHOULD BE SUPERVISED TO ENSURE THAT THEY DO NOT PLAY WITH THE EQUIPMENT.

THE MANUFACTURER WILL NOT BE RESPONSIBLE FOR ANY INJURY OR PROPERTY DAMAGE ARISING FROM IMPROPER SUPERVISION, SERVICE OR SERVICE PROCEDURES. IF YOU SERVICE THIS UNIT, YOU ASSUME RESPONSIBILITY FOR ANY INJURY OR PROPERTY DAMAGE WHICH MAY RESULT. IN ADDITION, IN JURISDICTIONS THAT REQUIRE ONE OR MORE LICENSES TO SERVICE THE EQUIPMENT SPECIFIED IN THIS MANUAL, ONLY LICENSED PERSONNEL SHOULD SERVICE THE EQUIPMENT. IMPROPER SUPERVISION, INSTALLATION, ADJUSTMENT, SERVICING, MAINTENANCE OR REPAIR OF THE EQUIPMENT SPECIFIED IN THIS MANUAL, OR ATTEMPTING TO INSTALL, ADJUST, SERVICE OR REPAIR THE EQUIPMENT SPECIFIED IN THIS MANUAL WITHOUT PROPER SUPERVISION OR TRAINING MAY RESULT IN PRODUCT DAMAGE, PROPERTY DAMAGE, PERSONAL INJURY OR DEATH.

SAFETY CONSIDERATIONS 2
 PRODUCT DESCRIPTION 4
 PRODUCT APPLICATION 4
 LOCATION REQUIREMENTS AND CONSIDERATIONS 5
 COMBUSTION AND VENTILATION AIR REQUIREMENTS 7
 CATEGORY I VENTING 9
 EXTERIOR MASONRY CHIMNEYS
 (CATEGORY I FURNACES ONLY) 10
 ELECTRICAL CONNECTIONS..... 10
 GAS SUPPLY AND PIPING 14
 CIRCULATING AIR 17
 START-UP PROCEDURE AND ADJUSTMENT..... 19
 DAIKIN COMMUNICATING SYSTEM 24
 DAIKIN COMMUNICATING SYSTEM ADVANCED FEATURES ... 26
 NORMAL SEQUENCE OF OPERATION 28
 OPERATIONAL CHECKS..... 30
 SAFETY CIRCUIT DESCRIPTION 30
 TROUBLESHOOTING..... 31
 MAINTENANCE 32
 BEFORE LEAVING AN INSTALLATION 33
 REPAIR AND REPLACEMENT PARTS..... 33
 TROUBLESHOOTING CHART..... 34
 STATUS CODES 39
 AIR FLOW DATA 40
 DIP SWITCHES 41
 WIRING DIAGRAM DM80VC/DC80VC 42
 START-UP CHECK LIST 43

! WARNING

DO NOT BYPASS SAFETY DEVICES.

80% HEX

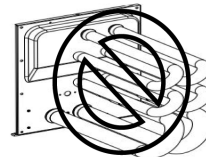

DO NOT LIFT
PRODUCT USING
HEAT EXCHANGER

Our continuing commitment to quality products may mean a change in specifications without notice.



SAFETY CONSIDERATIONS

Adhere to the following warnings and cautions when installing, adjusting, altering, servicing, or operating the furnace. To ensure proper installation and operation, thoroughly read this manual for specifics pertaining to the installation and application of this product.

This furnace is manufactured for use with natural gas. It may be field converted to operate on L.P. gas by using the appropriate L.P. conversion kit listed in the **PROPANE GAS/HIGH ALTITUDE INSTALLATIONS** section of this manual.

Install this furnace only in a location and position as specified in **LOCATION REQUIREMENTS & CONSIDERATIONS** section and **INSTALLATION POSITIONS** section of this manual.

Provide adequate combustion and ventilation air to the furnace as specified in **COMBUSTION & VENTILATION AIR REQUIREMENTS** section of this manual.

Combustion products must be discharged to the outdoors. Connect this furnace to an approved vent system only, as specified in **Category 1 Venting** section of this manual.

Never test for gas leaks with an open flame. Use a commercially available soap solution made specifically for the detection of leaks to check all connections, as specified in **GAS SUPPLY AND PIPING** section of this manual.

Always install a furnace to operate within the furnace's intended temperature-rise range with a duct system which has external static pressure within the allowable range, as specified on the furnace rating plate and **OPERATIONAL CHECKS** section of these instructions.

When a furnace is installed so that supply ducts carry air circulated by the furnace to areas outside the space containing the furnace, the return air shall also be handled by duct(s) sealed to the furnace casing and terminating outside the space containing the furnace.

A gas-fired furnace for installation in a residential garage must be installed as specified in the **LOCATION REQUIREMENTS AND CONSIDERATIONS** section of this manual.

This furnace may be used as a construction site heater only if certain conditions are met. These conditions are listed in the **PRODUCT APPLICATION** section of this manual.



WARNING

FIRE OR EXPLOSION HAZARD

FAILURE TO FOLLOW THE SAFETY WARNINGS EXACTLY COULD RESULT IN SERIOUS INJURY, DEATH OR PROPERTY DAMAGE.

NEVER TEST FOR GAS LEAKS WITH AN OPEN FLAME. USE A COMMERCIALY AVAILABLE SOAP SOLUTION MADE SPECIFICALLY FOR THE DETECTION OF LEAKS TO CHECK ALL CONNECTIONS. A FIRE OR EXPLOSION MAY RESULT CAUSING PROPERTY DAMAGE, PERSONAL INJURY OR LOSS OF LIFE.



AVERTISSEMENT

RISQUE D'INCENDIE OU D'EXPLOSION

SI LES CONSIGNES DE SÉCURITÉ NE SONT PAS SUIVIES À LA LETTRE, CELA PEUT ENTRAÎNER LA MORT, DE GRAVES BLESSURES OU DES DOMMAGES MATÉRIELS.

NE JAMAIS VÉRIFIER LA PRÉSENCE DE FUITES DE GAZ AU MOYEN D'UNE FLAMME NUE. VÉRIFIER TOUS LES RACCORDS EN UTILISANT UNE SOLUTION SAVONNEUSE COMMERCIALE CONÇUE SPÉCIALEMENT POUR LA DÉTECTION DE FUITES. UN INCENDIE OU UNE EXPLOSION RISQUE DE SE PRODUIRE, CE QUI PEUT ENTRAÎNER LA MORT, DES BLESSURES OU DES DOMMAGES MATÉRIELS.



WARNING

TO PREVENT PERSONAL INJURY OR DEATH DUE TO IMPROPER INSTALLATION, ADJUSTMENT, ALTERATION, SERVICE OR MAINTENANCE, REFER TO THIS MANUAL. FOR ADDITIONAL ASSISTANCE OR INFORMATION, CONSULT A QUALIFIED INSTALLER, SERVICER AGENCY OR THE GAS SUPPLIER.



WARNING

IF THE INFORMATION IN THESE INSTRUCTIONS IS NOT FOLLOWED EXACTLY, A FIRE OR EXPLOSION MAY RESULT CAUSING PROPERTY DAMAGE, PERSONAL INJURY OR LOSS OF LIFE.

- DO NOT STORE OR USE GASOLINE OR OTHER FLAMMABLE VAPORS AND LIQUIDS IN THE VICINITY OF THIS OR ANY OTHER APPLIANCE.
- WHAT TO DO IF YOU SMELL GAS:
 - DO NOT TRY TO LIGHT ANY APPLIANCE.
 - DO NOT TOUCH ANY ELECTRICAL SWITCH; DO NOT USE ANY PHONE IN YOUR BUILDING.
 - IMMEDIATELY CALL YOUR GAS SUPPLIER FROM A NEIGHBOR'S PHONE. FOLLOW THE GAS SUPPLIER'S INSTRUCTIONS. IF YOU CANNOT REACH YOUR GAS SUPPLIER, CALL THE FIRE DEPARTMENT.
- INSTALLATION AND SERVICE MUST BE PERFORMED BY A QUALIFIED INSTALLER, SERVICE AGENCY OR THE GAS SUPPLIER.

DANGER



CARBON MONOXIDE POISONING HAZARD

Special Warning for Installation of Furnace or Air Handling Units in Enclosed Areas such as Garages, Utility Rooms or Parking Areas

Carbon monoxide producing devices (such as an automobile, space heater, gas water heater, etc.) should not be operated in enclosed areas such as unventilated garages, utility rooms or parking areas because of the danger of carbon monoxide (CO) poisoning resulting from the exhaust emissions. If a furnace or air handler is installed in an enclosed area such as a garage, utility room or parking area and a carbon monoxide producing device is operated therein, there must be adequate, direct outside ventilation.

This ventilation is necessary to avoid the danger of CO poisoning which can occur if a carbon monoxide producing device continues to operate in the enclosed area. Carbon monoxide emissions can be (re)circulated throughout the structure if the furnace or air handler is operating in any mode.

CO can cause serious illness including permanent brain damage or death. B10259-216

DANGER PELIGRO



RIESGO DE INTOXICACIÓN POR MONÓXIDO DE CARBONO

Advertencia especial para la instalación de calentadores ó manejadoras de aire en áreas cerradas como estacionamientos ó cuartos de servicio.

Los equipos ó aparatos que producen monóxido de carbono (tal como automóvil, calentador de gas, calentador de agua por medio de gas, etc) no deben ser operados en áreas cerradas debido al riesgo de envenenamiento por monóxido de carbono (CO) que resulta de las emisiones de gases de combustión. Si el equipo ó aparato se opera en dichas áreas, debe existir una adecuada ventilación directa al exterior. Esta ventilación es necesaria para evitar el peligro de envenenamiento por CO, que puede ocurrir si un dispositivo que produce monóxido de carbono sigue operando en el lugar cerrado.

Las emisiones de monóxido de carbono pueden circular a través del aparato cuando se opera en cualquier modo.

El monóxido de carbono puede causar enfermedades severas como daño cerebral permanente ó muerte. B10259-216

DANGER



RISQUE D'EMPOISONNEMENT AU MONOXYDE DE CARBONE

Advertencia especial para la instalación de calentadores ó manejadoras de aire en áreas cerradas como estacionamientos ó cuartos de servicio.

Avertissement special au sujet de l'installation d'appareils de chauffage ou de traitement d'air dans des endroits clos, tels les garages, les locaux d'entretien et les stationnements. Evitez de mettre en marche les appareils produisant du monoxyde de carbone (tels que les automobile, les appareils de chauffage autonome, etc.) dans des endroits non ventilés tels que les d'empoisonnement au monoxyde de carbone. Si vous devez faire fonctionner ces appareils dans un endroit clos, assurez-vous qu'il y ait une ventilation directe provenant de l'exterieur.

Cette ventilation est nécessaire pour éviter le danger d'intoxication au CO pouvant survenir si un appareil produisant du monoxyde de carbone continue de fonctionner au sein de la zone confinée.

Les émissions de monoxyde de carbone peuvent étre recirculées dans les endroits clos, si l'appareil de chauffage ou de traitement d'air sont en marche.

Le monoxyde de carbone peut causer des maladies graves telles que des dommages permanents au cerveau et meme la mort. B10259-216

WARNING

HEATING UNIT SHOULD NOT BE UTILIZED WITHOUT REASONABLE, ROUTINE, INSPECTION, MAINTENANCE AND SUPERVISION. IF THE BUILDING IN WHICH ANY SUCH DEVICE IS LOCATED WILL BE VACANT, CARE SHOULD BE TAKEN THAT SUCH DEVICE IS ROUTINELY INSPECTED, MAINTAINED AND MONITORED. IN THE EVENT THAT THE BUILDING MAYBE EXPOSED TO FREEZING TEMPERATURES AND WILL BE VACANT, ALL WATER-BEARING PIPES SHOULD BE DRAINED, THE BUILDING SHOULD BE PROPERLY WINTERIZED, AND THE WATER SOURCE CLOSED. IN THE EVENT THAT THE BUILDING MAY BE EXPOSED TO FREEZING TEMPERATURES AND WILL BE VACANT, ANY HYDRONIC COIL UNITS SHOULD BE DRAINED AS WELL AND, IN SUCH CASE, ALTERNATIVE HEAT SOURCES SHOULD BE UTILIZED.

WARNING

TO PREVENT PERSONAL INJURY OR DEATH DUE TO IMPROPER INSTALLATION, ADJUSTMENT, ALTERATION, SERVICE OR MAINTENANCE, REFER TO THIS MANUAL. FOR ADDITIONAL ASSISTANCE OR INFORMATION, CONSULT A QUALIFIED INSTALLER, SERVICER AGENCY OR THE GAS SUPPLIER.

WARNING

TO PREVENT POSSIBLE PROPERTY DAMAGE, PERSONAL INJURY OR DEATH DUE TO ELECTRICAL SHOCK, THE FURNACE MUST BE LOCATED TO PROTECT THE ELECTRICAL COMPONENTS FROM WATER.

WARNING

SHOULD OVERHEATING OCCUR OR THE GAS SUPPLY FAIL TO SHUT OFF, TURN OFF THE MANUAL GAS SHUTOFF VALVE EXTERNAL TO THE FURNACE BEFORE TURNING OFF THE ELECTRICAL SUPPLY.

WARNING

POSSIBLE PROPERTY DAMAGE, PERSONAL INJURY OR DEATH DUE TO FIRE, EXPLOSION, SMOKE, SOOT, CONDENSATION, ELECTRICAL SHOCK OR CARBON MONOXIDE MAY RESULT FROM IMPROPER INSTALLATION, REPAIR OPERATION, OR MAINTENANCE OF THIS PRODUCT.

SHIPPING INSPECTION

All units are securely packed in shipping containers tested according to International Safe Transit Association specifications. The carton must be checked upon arrival for external damage. If damage is found, a request for inspection by carrier's agent must be made in writing immediately.

The furnace must be carefully inspected on arrival for damage and bolts or screws which may have come loose in transit. In the event of damage the consignee should:

1. Make a notation on delivery receipt of any visible damage to shipment or container.
2. Notify carrier promptly and request an inspection.
3. With concealed damage, carrier must be notified as soon as possible - preferably within five days.

WARNING

TO PREVENT PERSONAL INJURY OR DEATH DUE TO ASPHYXIATION, THIS FURNACE MUST BE CATEGORY I VENTED. DO NOT VENT USING CATEGORY III VENTING. PROVISIONS MUST BE MADE FOR PROPER VENTING SYSTEM. THE LENGTH OF FLUE PIPE COULD BE A LIMITING FACTOR IN LOCATING THE FURNACE.

ADDITIONAL SAFETY CONSIDERATIONS

- This furnace is approved for Category I Venting only.
 - Provisions must be made for venting combustion products outdoors through a proper venting system. The length of flue pipe could be a limiting factor in locating the furnace.
4. File the claim with the following support documents within a nine month statute of limitations.
- Original or certified copy of the Bill of Lading, or indemnity bond.
 - Original paid freight bill or indemnity in lieu thereof.
 - Original or certified copy of the invoice, showing trade and other discounts or reductions.
 - Copy of the inspection report issued by carrier's representative at the time damage is reported to carrier.

The carrier is responsible for making prompt inspection of damage and for a thorough investigation of each claim. The distributor or manufacturer will not accept claims from dealers for transportation damage.

Keep this literature in a safe place for future reference.

ELECTROSTATIC DISCHARGE (ESD) PRECAUTIONS

NOTE: DISCHARGE BODY'S STATIC ELECTRICITY BEFORE TOUCHING UNIT. AN ELECTROSTATIC DISCHARGE CAN ADVERSELY AFFECT ELECTRICAL COMPONENTS.

Use the following precautions during furnace installation and servicing to protect the integrated control module from damage. By putting the furnace, the control, and the person at the same electrostatic potential, these steps will help avoid exposing the integrated control module to electrostatic discharge. This procedure is applicable to both installed and non-installed (ungrounded) furnaces.

1. Disconnect all power to the furnace. Do not touch the integrated control module or any wire connected to the control prior to discharging your body's electrostatic charge to ground.
2. Firmly touch clean, unpainted, metal surface of the furnaces near the control. Any tools held in a person's hand during grounding will be discharged.
3. Service integrated control module or connecting wiring following the discharge process in step 2. Use caution not to recharge your body with static electricity; (i.e., do not move or shuffle your feet, do not touch ungrounded objects, etc.). If you come in contact with an ungrounded object, repeat step 2 before touching control or wires.
4. Discharge your body to ground before removing a new control from its container. Follow steps 1 through 3 if installing the control on a furnace. Return any old or new controls to their containers before touching any ungrounded object.

TO THE INSTALLER

Before installing this unit, please read this manual thoroughly to familiarize yourself with specific items which must be adhered to, including but not limited to: unit

maximum external static pressure, gas pressures, BTU input rating, proper electrical connections, circulating air temperature rise, minimum or maximum CFM, and motor speed connections, and venting. These furnaces are designed for Category I venting only.



WARNING

TO PREVENT PROPERTY DAMAGE, PERSONAL INJURY OR DEATH DUE TO FIRE, DO NOT INSTALL THE FURNACE IN A MOBILE HOME, TRAILER, OR RECREATIONAL VEHICLE.

PRODUCT DESCRIPTION

FEATURES

This furnace is a part of the communicating family of products. A Daikin communicating thermostat allows this furnace to be installed as part of a digitally communicating system. The Communicating system provides advanced airflow configuration, enhanced setup features, and enhanced diagnostics. It also reduces the number of thermostat wires to a maximum of four. It may be also installed as part of a "legacy" system using a standard 24 VAC thermostat.

This product may also be installed with the communicating thermostat and a non-communicating compatible single stage air conditioning unit. However, this reduces the benefits of the communicating system as the enhancements will only apply to the furnace.

PRODUCT APPLICATION

This furnace is primarily designed for residential home-heating applications. It is NOT designed or certified for use in mobile homes, trailers or recreational vehicles. Neither is it designed or certified for outdoor applications. The furnace **must** be installed indoors (i.e., attic space, crawl space, or garage area provided the garage area is enclosed with an operating door).

This furnace can be used in the following non-industrial commercial applications:

Schools, Office buildings, Churches, Retail stores, Nursing homes, Hotels/motels, Common or office areas

In such applications, the furnace must be installed with the following stipulations:

- It must be installed per the installation instructions provided and per local and national codes.
- It must be installed indoors in a building constructed on site.
- It must be part of a ducted system and not used in a free air delivery application.
- It must not be used as a "make-up" air unit.
- All other warranty exclusions and restrictions apply.

This furnace may be used as a construction site heater **ONLY** if all of the following conditions are met:

- The vent system is permanently installed per these installation instructions.
- A room thermostat is used to control the furnace. Fixed jumpers that provide continuous heating CANNOT be used and can cause long term equipment damage. Bi-metal thermostats, or any thermostat affected by vibration must not be used during construction.
- Return air ducts are provided and sealed to the furnace.
- A return air temperature range between 60°F (16°C) and 80°F (27°C) is maintained.
- Air filters are installed in the system and replaced daily during construction and upon completion of construction.
- The input rate and temperature rise are set per the furnace rating plate.
- 100% outside air must be used for combustion during construction. Temporary ducting may be used to supply outside air to the furnace for combustion – do not connect this duct directly to the furnace. Size this duct according to NFPA 54/ANSI Z223.1 section for Combustion and Ventilation Air.
- The furnace heat exchanger, components, duct system, air filters and evaporator coils are thoroughly cleaned following final construction clean up by a qualified person.
- All furnace operating conditions (including ignition, input rate, temperature rise and venting) are verified by a qualified person according to these installation instructions.
- Furnace doors must be in place on the furnace while the furnace is operating in any mode.
- Damage or repairs due to failure to comply with these requirements are not covered under the warranty.

NOTE: THE COMMONWEALTH OF MASSACHUSETTS REQUIRES THAT THE FOLLOWING ADDITIONAL REQUIREMENTS MUST ALSO BE MET:

- Gas furnaces must be installed by a licensed plumber or gas fitter.
- A T-handle gas cock must be used.
- If the unit is to be installed in an attic, the passageway to and the service area around the unit must have flooring.

 WARNING
TO PREVENT PROPERTY DAMAGE, PERSONAL INJURY OR DEATH DUE TO FIRE, DO NOT INSTALL THE FURNACE IN A MOBILE HOME, TRAILER, OR RECREATIONAL VEHICLE.

To ensure proper furnace operation, install, operate and maintain the furnace in accordance with these installation and operation instructions, all local building codes and ordinances. In their absence, follow the latest edition of the National Fuel Gas Code (NFPA 54/ANSI Z223.1) and/or local plumbing or waste water codes, and other applicable codes.

A copy of the National Fuel Gas Code (NFPA 54/ANSI Z223.1) can be obtained from any of the following:

American National Standards Institute
25 West 43rd Street, 4th Floor

New York, NY 10036

National Fire Protection Association

1 Batterymarch Park
Quincy, MA 02169-7471

CSA International

8501 East Pleasant Valley
Cleveland, OH 44131

The rated heating capacity of the furnace should be greater than or equal to the total heat loss of the area to be heated. The total heat loss should be calculated by an approved method or in accordance with “ASHRAE Guide” or “Manual J-Load Calculations” published by the Air Conditioning Contractors of America.

In the USA, this furnace MUST be installed in accordance with the latest edition of the ANSI Z223.1 booklet entitled “National Fuel Gas Code” (NFPA 54), and the requirements or codes of the local utility or other authority having jurisdiction. Additional helpful publications available from the NFPA are, NFPA 90A - Installation of Air Conditioning and Ventilating System and NFPA 90B - Warm Air Heating and Air Conditioning System.

All venting shall be in accordance with the National Fuel Gas Code, ANSI Z223.1, or applicable local building and/or air conditioning codes.

NOTE: FURNACES WITH NOX SCREENS MEET THE CALIFORNIA NOX EMISSION STANDARDS AND CALIFORNIA SEASONAL EFFICIENCY STANDARDS. ANNUAL INSPECTIONS OF THE FURNACE AND ITS VENT SYSTEM IS STRONGLY RECOMMENDED.

LOCATION REQUIREMENTS AND CONSIDERATIONS

Your unit model type determines which installation procedures must be used. For DM80VC models, you must follow instructions for Horizontal Left, Horizontal Right or Upflow installations only. These furnaces are not approved for Downflow installations.

DC80VC models may be installed in the Downflow position as well as Horizontal Left & Horizontal Right positions.

 WARNING
TO PREVENT POSSIBLE EQUIPMENT DAMAGE, PROPERTY DAMAGE, PERSONAL INJURY OR DEATH, THE FOLLOWING BULLET POINTS MUST BE OBSERVED WHEN INSTALLING THIS UNIT.

Follow the instructions listed below when selecting a furnace location. Refer also to the guidelines provided in the *Combustion and Ventilation Air Requirements*.

- Centrally locate the furnace with respect to the proposed or existing air distribution system.
- Ensure the temperature of the return air entering the furnace is between 55°F and 100°F when the furnace is heating.
- Provisions must be made for venting combustion products outdoors through a proper venting system. The length of flue pipe could be a limiting factor in locating the furnace.
- Ensure adequate combustion air is available for the furnace. Improper or insufficient combustion air can expose building occupants to gas combustion products that could include carbon monoxide. Refer to *Combustion and Ventilation Air Requirements* section.
- The furnace must be level. If the furnace is to be set on a floor that may become wet or damp at times, the furnace should be supported above the floor on a concrete base sized approximately 1-½" larger than the base of the furnace.
- Ensure upflow or horizontal furnaces are not installed directly on carpeting, or any other combustible material. The only combustible material allowed is wood.
- Exposure to contaminated combustion air will result in safety and performance-related problems. Do not install the furnace where the combustion air is exposed to the following substances:
 - chlorinated waxes or cleaners
 - chlorine-based swimming pool chemicals
 - water softening chemicals
 - deicing salts or chemicals
 - carbon tetrachloride
 - halogen type refrigerants
 - cleaning solutions (such as perchloroethylene)
 - printing inks
 - paint removers
 - varnishes
 - hydrochloric acid
 - cements and glues
 - antistatic fabric softeners for clothes dryers and masonry acid washing materials
- If the furnace is used in connection with a cooling unit, install the furnace upstream or in parallel with the cooling unit coil. Premature heat exchanger failure will result if the cooling unit coil is placed ahead of the furnace.
- For vertical applications, the minimum cooling coil width shall not be less than furnace width minus 1". Additionally, a coil installed above an upflow furnace or under a counterflow furnace may be the same width as the furnace or may be one size larger than the furnace. Example: a "C" width coil may be installed with a "B" width furnace.

- For upflow applications, the front of the coil and furnace must face the same direction.
- If the furnace is installed in a residential garage, position the furnace so that the burners and ignition source are located not less than 18 inches (457 mm) above the floor. Protect the furnace from physical damage by vehicles.
- If the furnace is installed horizontally, the furnace access doors must be vertical so that the burners fire horizontally into the heat exchanger. Do not install the unit with the access doors on the "up/top" or "down/bottom" side of the furnace.
- Do not connect this furnace to a chimney flue that serves a separate appliance designed to burn solid fuel.
- Counterflow installation over a noncombustible floor. Before setting the furnace over the plenum opening, ensure the surface around the opening is smooth and level. A tight seal should be made between the furnace base and floor by using a silicon rubber caulking compound or cement grout.
- Counterflow installation over a combustible floor. If installation over a combustible floor becomes necessary, use an accessory subbase (see Specification Sheet applicable to your model for details). A special accessory subbase must be used for upright counterflow unit installations over any combustible material including wood. Follow the instructions with the subbase for proper installations. Do not install the furnace directly on carpeting, tile, or other combustible material other than wood flooring.

NOTE: THE SUBBASE WILL NOT BE REQUIRED IF AN AIR CONDITIONING COIL IS INSTALLED BETWEEN THE SUPPLY AIR OPENING ON THE FURNACE AND THE FLOOR. THE AIR CONDITIONING COIL MUST BE DOWNSTREAM FROM THE HEAT EXCHANGER OF THE FURNACE.

Vent Pipe Clearance to Combustibles- 6" using Single Wall Connector or 1" using B-1 vent.

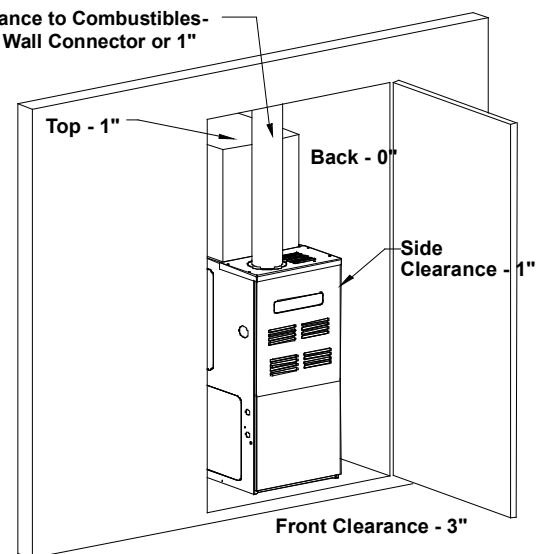

- Adequate combustion/ventilation air must be supplied to the closet.
- Furnace must be **completely** sealed to floor or base. Combustion / ventilation air supply pipes must terminate 12" from top of closet and 12" from floor of closet. DO NOT remove solid base plate for side return.
- Return air ducts must be **completely** sealed to the furnace and terminate outside the enclosure surfaces.

CLEARANCES AND ACCESSIBILITY

Clearance in accordance with local installation codes, the requirements of the gas supplier and the manufacturer's installation instructions.

Dégagement conforme aux codes d'installation locaux, aux exigences du fournisseur de gaz et aux instructions d'installation du fabricant.

Unobstructed front clearance of 24" **for servicing** is recommended.

VENT		SIDES	FRONT	BACK	TOP (PLENUM)
B1-VENT	SINGLE				
1"	6"	1"	3"	0"	1"

TOP CLEARANCE FOR HORIZONTAL CONFIGURATION - 1"

INSTALLATION POSITIONS

DM80VC model furnaces may be installed vertically (upflow) or horizontally with left or right side down. DC80VC model furnaces may be installed vertically (downflow) or horizontally with left or right side down. Do not install this furnace on its back. For vertically installed *upflow* furnaces, return air ductwork may be attached to the side panel(s) and/or basepan. For *horizontally* installed *upflow* furnaces, return air ductwork must be attached to the basepan. For *counterflow* furnaces, return ductwork must be attached to the blower compartment end of the furnace.

NOTE: DUCTWORK MUST NEVER BE ATTACHED TO THE BACK OF THE FURNACE.

HORIZONTAL INSTALLATION

Line contact to framing is permitted when installed in the horizontal configuration. Line contact is defined as the portion of the cabinet that is formed by the intersection of the top and side. ACCESSIBILITY CLEARANCE, WHERE GREATER, SHOULD TAKE PRECEDENCE OVER MINIMUM FIRE PROTECTION CLEARANCE. A gas-fired furnace for installation in a residential garage must be installed so that the ignition source and burners are located not less than eighteen inches (18") above the floor and is protected or located to prevent physical damage by vehicles. A gas furnace must not be installed directly on carpeting, tile, or other combustible materials other than wood flooring.

FURNACE SUSPENSION

If suspending the furnace from rafters or joist, use 3/8" threaded rod and 2"x2"x3/8" angle iron as shown below. The length of rod will depend on the application and the clearances necessary.

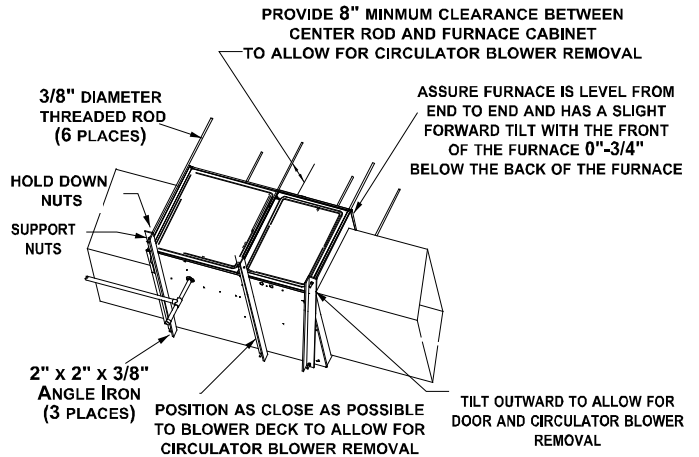

SUSPENDED FURNACE

EXISTING FURNACE REMOVAL

NOTE: WHEN AN EXISTING FURNACE IS REMOVED FROM A VENTING SYSTEM SERVING OTHER APPLIANCES, THE VENTING SYSTEM MAY BE TOO LARGE TO PROPERLY VENT THE REMAINING ATTACHED APPLIANCES.

THERMOSTAT LOCATION

In an area having good air circulation, locate the thermostat about five feet high on a vibration-free inside wall. Do not install the thermostat where it may be influenced by any of the following:

- Drafts, or dead spots behind doors, in corners, or under cabinets.
- Hot or cold air from registers.
- Radiant heat from the sun.
- Light fixtures or other appliances.
- Radiant heat from a fireplace.
- Concealed hot or cold water pipes, or chimneys.
- Unconditioned areas behind the thermostat, such as an outside wall.

Consult the instructions packaged with the thermostat for mounting instructions and further precautions.

COMBUSTION AND VENTILATION AIR REQUIREMENTS

 WARNING
<p>TO AVOID PROPERTY DAMAGE, PERSONAL INJURY OR DEATH, SUFFICIENT FRESH AIR FOR PROPER COMBUSTION AND VENTILATION OF FLUE GASES MUST BE SUPPLIED. MOST HOMES REQUIRE OUTSIDE AIR BE SUPPLIED INTO THE FURNACE AREA.</p>



WARNING

CARBON MONOXIDE POISONING HAZARD

FAILURE TO FOLLOW THE STEPS OUTLINED BELOW FOR EACH APPLIANCE CONNECTED TO THE VENTING SYSTEM BEING PLACED INTO OPERATION COULD RESULT IN CARBON MONOXIDE POISONING OR DEATH.

THE FOLLOWING STEPS SHALL BE FOLLOWED WITH EACH APPLIANCE CONNECTED TO THE VENTING SYSTEM PLACED IN OPERATION, WHILE ANY OTHER APPLIANCES CONNECTED TO THE VENTING SYSTEM ARE NOT IN OPERATION:

1. SEAL ANY UNUSED OPENINGS IN THE VENTING SYSTEM.
2. INSPECT THE VENTING SYSTEM FOR PROPER SIZE AND HORIZONTAL PITCH, AS REQUIRED BY THE NATIONAL FUEL GAS CODE, ANSI Z223.1 OR THE NATURAL GAS AND PROPANE INSTALLATION CODE, CSA B149.1-15 AND THESE INSTRUCTIONS. DETERMINE THAT THERE IS NO BLOCKAGE OR RESTRICTION, LEAKAGE, CORROSION AND OTHER DEFICIENCIES WHICH COULD CAUSE AN UNSAFE CONDITION.
3. AS FAR AS PRACTICAL, CLOSE ALL BUILDING DOORS AND WINDOWS AND ALL DOORS BETWEEN THE SPACE IN WHICH THE APPLIANCE(S) CONNECTED TO THE VENTING SYSTEM ARE LOCATED AND OTHER SPACES OF THE BUILDING.
4. CLOSE FIREPLACE DAMPERS.
5. TURN ON CLOTHES DRYERS AND ANY APPLIANCE NOT CONNECTED TO THE VENTING SYSTEM. TURN ON ANY EXHAUST FANS, SUCH AS RANGE HOODS AND BATHROOM EXHAUSTS, SO THEY SHALL OPERATE AT MAXIMUM SPEED. DO NOT OPERATE A SUMMER EXHAUST FAN.
6. FOLLOW THE LIGHTING INSTRUCTIONS. PLACE THE APPLIANCE BEING INSPECTED IN OPERATION. ADJUST THERMOSTAT SO APPLIANCE SHALL OPERATE CONTINUOUSLY.
7. TEST FOR SPILLAGE FROM DRAFT HOOD APPLIANCES AT THE DRAFT HOOD RELIEF OPENING AFTER 5 MINUTES OF MAIN BURNER OPERATION. USE THE FLAME OF A MATCH OR CANDLE.
8. IF IMPROPER VENTING IS OBSERVED DURING ANY OF THE ABOVE TESTS, THE VENTING SYSTEM MUST BE CORRECTED IN ACCORDANCE WITH THE NATIONAL FUEL GAS CODE ANSI Z223.1/NFPA 54 AND/OR NATIONAL GAS AND PROPANE INSTALLATION CODE CSA B149.1-15.
9. AFTER IT HAS BEEN DETERMINED THAT EACH APPLIANCE CONNECTED TO THE VENTING SYSTEM PROPERLY VENTS WHEN TESTED AS OUTLINED ABOVE, RETURN DOORS, WINDOWS, EXHAUST FANS, FIREPLACE DAMPERS AND ANY OTHER GAS BURNING APPLIANCE TO THEIR PREVIOUS CONDITIONS OF USE.



AVERTISSEMENT

RISQUE D'INTOXICATION AU MONOXYDE DE CARBONE

SI LES ÉTAPES DÉCRITES CI-DESSOUS NE SONT PAS SUIVIES POUR CHACUN DES APPAREILS RACCORDÉS AU SYSTÈME DE VENTILATION AU MOMENT DE SA MISE EN MARCHÉ, CELA PEUT ENTRAÎNER UNE INTOXICATION AU MONOXYDE DE CARBONE OU LA MORT.

LES ÉTAPES SUIVANTES DOIVENT ÊTRE SUIVIES POUR CHACUN DES APPAREILS RACCORDÉS AU SYSTÈME DE VENTILATION AU MOMENT DE SA MISE EN MARCHÉ, ALORS QUE TOUS LES AUTRES APPAREILS RACCORDÉS AU SYSTÈME DE VENTILATION NE SONT PAS EN MARCHÉ :

1. SCELLER TOUTES LES OUVERTURES INUTILISÉES DU SYSTÈME DE VENTILATION.
2. INSPECTER LE SYSTÈME DE VENTILATION AFIN DE VÉRIFIER SI LA TAILLE ET L'INCLINAISON PAR RAPPORT À L'HORIZONTALE SONT CONFORMES AUX EXIGENCES DU NATIONAL FUEL GAS CODE, ANSI Z223.1/NFPA 54 OU DU CODE D'INSTALLATION DU GAZ NATUREL ET DU PROPANE, CSA B149.1 ET À CES INSTRUCTIONS. VÉRIFIER QU'IL N'Y A PAS D'OBSTRUCTION OU DE RESTRICTION, DE FUITE, DE CORROSION ET D'AUTRES PROBLÈMES QUI POURRAIENT ENTRAÎNER UNE SITUATION DANGEREUSE.
3. SI POSSIBLE, FERMER TOUTES LES PORTES ET FENÊTRES DU BÂTIMENT AINSI QUE TOUTES LES PORTES SÉPARANT L'ENDROIT OÙ SE TROUVENT LES APPAREILS RACCORDÉS AU SYSTÈME DE VENTILATION ET LES AUTRES ZONES DU BÂTIMENT.
4. FERMER LE REGISTRE DES FOYERS.
5. METTRE LES SÈCHEUSES EN MARCHÉ AINSI QUE TOUS LES AUTRES APPAREILS QUI NE SONT PAS RACCORDÉS AU SYSTÈME DE VENTILATION. METTRE EN MARCHÉ TOUS LES VENTILATEURS DE TIRAGE, COMME CELUI DES HOTTES DE CUISINE ET DES SALLES DE BAINS, ET LES RÉGLER À LA PUISSANCE MAXIMALE. NE PAS METTRE EN MARCHÉ LES VENTILATEURS D'ÉTÉ.
6. SUIVRE LES INSTRUCTIONS D'ALLUMAGE. METTRE EN MARCHÉ L'APPAREIL SOUMIS À L'INSPECTION. RÉGLER LE THERMOSTAT DE MANIÈRE À CE QUE L'APPAREIL FONCTIONNE EN CONTINU.
7. VÉRIFIER LA PRÉSENCE DE FUITE AU NIVEAU DE L'OUVERTURE DU COUPE-TIRAGE DES APPAREILS QUI EN SONT DOTÉS APRÈS 5 MINUTES DE FONCTIONNEMENT DU BRÛLEUR PRINCIPAL. UTILISER LA FLAMME D'UNE ALLUMETTE OU D'UNE BOUGIE.
8. SI UN PROBLÈME DE VENTILATION EST OBSERVÉ PENDANT L'UN DES ESSAIS DÉCRITS CI-DESSUS, DES CORRECTIFS DOIVENT ÊTRE APPORTÉS AU SYSTÈME DE VENTILATION CONFORMÉMENT AU NATIONAL FUEL GAS CODE, ANSI Z223.1/NFPA 54 ET (OU) AU CODE D'INSTALLATION DU GAZ NATUREL ET DU PROPANE, CSA B149.1.
9. UNE FOIS QU'IL A ÉTÉ DÉTERMINÉ QUE CHAQUE APPAREIL RACCORDÉ AU SYSTÈME DE VENTILATION FONCTIONNE CORRECTEMENT AU MOYEN DES ESSAIS DÉCRITS CI-DESSUS, LES PORTES, LES FENÊTRES, LES VENTILATEURS, LES REGISTRES DE FOYER ET TOUS LES AUTRES APPAREILS DE COMBUSTION ALIMENTÉS AU GAZ DOIVENT ÊTRE REMIS DANS LEUR ÉTAT INITIAL.

If this furnace is to be installed in the same space with other gas appliances, such as a water heater, ensure there is an adequate supply of combustion and ventilation air for all appliances. Refer to the latest edition of the National Fuel Gas Code NFPA 54/ANSI Z223.1 or CAN/CSA B149 Installation Codes or applicable provisions of the local building codes for determining the combustion air requirements for the appliances.

This furnace must use indoor air for combustion. It cannot be installed as a direct vent (i.e., sealed combustion) furnace.

Most homes will require outside air be supplied to the furnace area by means of ventilation grilles or ducts connecting directly to the outdoors or spaces open to the outdoors such as attics or crawl spaces.

CATEGORY I VENTING (VERTICAL VENTING)



WARNING

TO PREVENT PERSONAL INJURY OR DEATH DUE TO ASPHYXIATION, THIS FURNACE MUST BE CATEGORY I VENTED. Do NOT VENT USING CATEGORY III VENTING.

Category I Venting is venting at a non-positive pressure. A furnace vented as Category I is considered a fan-assisted appliance and the vent system does not have to be “gas tight”. **NOTE:** Single stage gas furnaces with induced draft blowers draw products of combustion through a heat exchanger allowing, in some instances, common venting with natural draft appliances (i.e. water heaters). All installations must be vented in accordance with National Fuel Gas Code NFPA 54/ANSI Z223.1 - latest edition.

NOTE: THE VERTICAL HEIGHT OF THE CATEGORY I VENTING SYSTEM MUST BE AT LEAST AS GREAT AS THE HORIZONTAL LENGTH OF THE VENTING SYSTEM.



WARNING

TO PREVENT POSSIBLE INJURY OR DEATH DUE TO ASPHYXIATION, COMMON VENTING WITH OTHER MANUFACTURER’S INDUCED DRAFT APPLIANCES IS NOT ALLOWED.

The minimum vent diameter for the Category I venting system is as shown:

MODEL	MINIMUM VENT	
	UPFLOW	COUNTERFLOW
060	4 inch	4 inch
080	4 inch	4 inch
100	5 inch	4 inch

Under some conditions, larger vents than those shown above may be required or allowed. *When an existing furnace is removed from a venting system serving other appliances*, the venting system may be too large to properly vent the remaining attached appliances.

Furnaces are shipped with the induced draft blower discharging from the top of the furnace. (“Top” is as viewed for an upflow installation.) The induced draft blower on DM80VC models can be rotated 90 degrees for Category I venting. For furnaces installed vertically or horizontally, a four-inch single wall pipe can be used to extend the induced draft blower outlet ½” beyond the furnace cabinet. On DM80VC furnaces installed upflow or horizontally with left side down, the draft inducer may be rotated

to discharge from the right side of the cabinet. When rotating the inducer, a chimney transition bottom kit (part # 0270F01119) is needed for proper alignment of the inducer outlet and the vent exit hole in the side of the cabinet. The inducer may NOT be rotated on *CVC8 model furnaces regardless of installation position.

THIS PRODUCT IS NOT DESIGNED FOR COUNTERCLOCKWISE INDUCED DRAFT BLOWER ROTATION.

Vent the furnace in accordance with the National Fuel Gas Code NFPA 54/ANSI Z223.1 - latest edition.

VENTING

THIS FURNACE IS NOT DESIGN CERTIFIED TO BE HORIZONTALLY VENTED.

To rotate the induced draft blower clockwise, you will need to purchase one (0270F01119) chimney transition bottom kit.

1. Disconnect electrical power from the furnace.
2. Disconnect the induced draft blower power leads, flue pipe, and pressure switch tubing.
3. Remove the round cutout from the right side of the wrapper.
4. Remove and save the four screws that fasten the induced draft blower to the flue collector box.
5. Remove and save the three screws that hold the chimney assembly to the induced draft blower.
6. Remove and save the four screws that fasten the chimney top to the chimney bottom.
7. Remove the chimney transition bottom from the transition bottom kit.
8. Install the chimney top with the four screws retained from step 6 onto the new chimney transition bottom from the transition bottom kit.
9. Install chimney assembly with the three screws retained from step 5 onto the induced draft blower.
10. Reinstall the induced draft blower rotating it 90 degrees clockwise from the original upflow configuration using the four screws retained in step 3. Ensure the gasket located between the induced draft blower and the collector box is rotated accordingly.
11. Reconnect the induced draft blower power leads. **NOTE:** If the wires are not long enough, pull extra wire from the wire bundle in the blower compartment.
12. Reconnect the flue pipe, and the pressure switch tubing. Ensure that all wires and the pressure switch tubing is at least one inch from the flue pipe, or any other hot surface.
13. Restore power to furnace.

Counterflow units are shipped with the induced draft blower discharging from the top of the furnace. (“Top” as viewed for a counterflow installation.)

Vent the furnace in accordance with the National Fuel Gas Code NFPA54/ANSI Z223.1-latest edition.



WARNING

NEVER ALLOW THE PRODUCTS OF COMBUSTION, INCLUDING CARBON MONOXIDE TO ENTER THE RETURN DUCTWORK OR CIRCULATION AIR SUPPLY.

EXTERIOR MASONRY CHIMNEYS (CATEGORY I FURNACES ONLY)

An exterior masonry chimney is defined as a “Masonry” chimney exposed to the outdoors on one or more sides below the roof line.” The ability to use a clay lined masonry chimney depends on a parameter not associated with interior chimneys. This variable is the geographic location of the installation. Researchers have discovered that the winter design temperatures have a direct impact on the suitability of this type of venting. In most situations, the existing masonry chimneys will require a properly sized metallic liner.



WARNING

POSSIBILITY OF PROPERTY DAMAGE, PERSONAL INJURY OR DEATH DAMAGING CONDENSATION CAN OCCUR INSIDE MASONRY CHIMNEYS WHEN A SINGLE FAN-ASSISTED CATEGORY I APPLIANCE (80% AFUE FURNACE) IS VENTED WITHOUT ADEQUATE DILUTION AIR. DO NOT CONNECT AN 80% FURNACE TO A MASONRY CHIMNEY UNLESS THE FURNACE IS COMMON VENTED WITH A DRAFT HOOD EQUIPPED APPLIANCE OR THE CHIMNEY IS LINED WITH A METAL LINER OR TYPE B METAL VENT. ALL INSTALLATIONS USING MASONRY CHIMNEYS MUST BE SIZED IN ACCORDANCE WITH THE APPROPRIATE VENTING TABLES. IF AN 80% FURNACE IS COMMON VENTED WITH A DRAFT GOOD EQUIPPED APPLIANCE, THE POTENTIAL FOR CONDENSATION DAMAGE MAY STILL EXIST WITH EXTREMELY COLD CONDITIONS, LONG VENT CONNECTORS, EXTERIOR CHIMNEYS, OR ANY COMBINATION OF THESE CONDITIONS. THE RISK OF CONDENSATION DAMAGE IS BEST AVOIDED BY USING MASONRY CHIMNEY AS A PATHWAY FOR PROPERLY SIZED METAL LINER OR TYPE B METAL VENT.

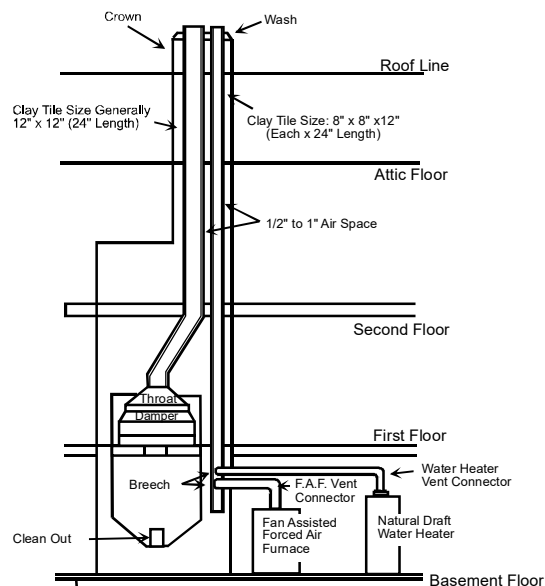

TYPICAL MULTIPLE FLUE CLAY TILE CHIMNEY

ELECTRICAL CONNECTIONS



WARNING

HIGH VOLTAGE

TO AVOID RISK OF ELECTRICAL SHOCK, WIRING TO THE UNIT MUST BE POLARIZED AND GROUNDED.



WARNING

HIGH VOLTAGE

TO AVOID PERSONAL INJURY OR DEATH DUE TO ELECTRICAL SHOCK, DISCONNECT ELECTRICAL POWER BEFORE SERVICING OR CHANGING ANY ELECTRICAL WIRING.



CAUTION

LABEL ALL WIRES PRIOR TO DISCONNECTION WHEN SERVICING CONTROLS. WIRING ERRORS CAN CAUSE IMPROPER AND DANGEROUS OPERATION AFTER SERVICING.



WARNING

HIGH VOLTAGE

TO AVOID THE RISK OF INJURY, ELECTRICAL SHOCK OR DEATH, THE FURNACE MUST BE ELECTRICALLY GROUNDED IN ACCORDANCE WITH LOCAL CODES OR IN THEIR ABSENCE, WITH THE LATEST EDITION OF THE NATIONAL ELECTRICAL CODE.



WIRING HARNESS

The wiring harness is an integral part of this furnace. Field alteration to comply with electrical codes should not be required. Wires are color coded for identification purposes. Refer to the wiring diagram for wire routings. If any of the original wire as supplied with the furnace must be replaced, it must be replaced with wiring material having a temperature rating of at least 105°C. Any replacement wiring must be a copper conductor.

115 VOLT LINE CONNECTIONS

Before proceeding with electrical connections, ensure that the supply voltage, frequency, and phase correspond to that specified on the unit rating plate. Power supply to the furnace must be NEC Class 1, and must comply with all applicable codes. The furnace must be electrically grounded in accordance with local codes or, in their absence, with the latest edition of The National Electric Code, ANSI NFPA 70 and/or The Canadian Electric Code CSA C22.1.

Use a separate fused branch electrical circuit containing properly sized wire, and fuse or circuit breaker. The fuse or circuit breaker must be sized in accordance with the maximum overcurrent protection specified on the unit rating plate. An electrical disconnect must be provided at the furnace location.

Connect hot, neutral, and ground wires as shown in the wiring diagram located on the unit's blower door. Metal conduit is not considered a substitute for an actual ground wire to the unit.

Line polarity must be observed when making field connections. Line voltage connections can be made through either the right or left side panel. The furnace is shipped configured for a right side electrical connection with the junction box located inside the burner compartment (blower compartment for downflows). To make electrical connections through the opposite side of the furnace, the junction box must be relocated to the other side of the burner (or blower) compartment prior to making electrical connections. To relocate the junction box, follow the steps shown below.

NOTE: WIRE ROUTING MUST NOT TO INTERFERE WITH CIRCULATOR BLOWER OPERATION, FILTER REMOVAL, OR ROUTINE MAINTENANCE.

JUNCTION BOX RELOCATION

 WARNING
EDGES OF SHEET METAL HOLES MAY BE SHARP. USE GLOVES AS A PRECAUTION WHEN REMOVING PLUGS.

Line voltage connections can be made through either the right or left side panel. The furnace is shipped configured for a right side electrical connection. To make electrical connections through the opposite side of the furnace, the junction box must be relocated to the left side prior to making electrical connections. To relocate the junction box, perform the following steps.

 WARNING
TO PREVENT PERSONAL INJURY, ELECTRICAL SHOCK, DISCONNECT ELECTRICAL POWER BEFORE INSTALLING OR SERVICING THIS UNIT.



1. Remove both doors from the furnace.
2. Remove and save the screws holding the junction box to the right side of the furnace.
3. Models that have the junction box located in the burner or blower compartment will need to move the junction box directly over.
4. Attach the junction box to the left side of the furnace, using the screws removed in step 2.
5. Check the location of the wiring. Confirm that it will not be damaged by heat from the burners or by the rotation of the fan. Also confirm that wiring location will not interfere with filter removal or other maintenance.

After the junction box is in the desired location, use washers to connect field-supplied conduit to the junction box in accordance with NEC and local codes. Connect hot, neutral, and ground wires as shown in the furnace wiring diagram. The wires and ground screw are located in the furnace junction box.

NOTE: IN DOWNFLOW APPLICATIONS THE POWER LEADS SHOULD BE ROUTED THROUGH THE SUPPLIED WIRE TABS WHEN LOCATING JUNCTION BOX TO THE LEFT SIDE.

Low voltage wires may be connected to the terminal strip.

IMPORTANT NOTE: To AVOID POSSIBLE EQUIPMENT MALFUNCTION, ROUTE THE LOW VOLTAGE WIRES TO AVOID INTERFERENCE WITH FILTER REMOVAL OR OTHER MAINTENANCE.

 WARNING	
HIGH VOLTAGE TO AVOID THE RISK OF INJURY, ELECTRICAL SHOCK OR DEATH, THE FURNACE MUST BE ELECTRICALLY GROUNDED IN ACCORDANCE WITH LOCAL CODES OR IN THEIR ABSENCE, WITH THE LATEST EDITION OF THE NATIONAL ELECTRICAL CODE.	

To ensure proper unit grounding, the ground wire should run from the furnace ground screw located inside the furnace junction box all the way back to the electrical panel. **NOTE:** Do not use gas piping as an electrical ground. To confirm proper unit grounding, turn off the electrical power and perform the following check.

1. Measure resistance between the neutral (white) connection and one of the burners.
2. Resistance should measure 10 ohms or less.

This furnace is equipped with a blower door interlock switch which interrupts unit voltage when the blower door is opened for servicing. Do not defeat this switch.

24 VOLT THERMOSTAT WIRING

IMPORTANT NOTE: WIRE ROUTING MUST NOT INTERFERE WITH CIRCULATOR BLOWER OPERATION, FILTER REMOVAL, OR ROUTINE MAINTENANCE. A REMOVABLE PLUG CONNECTOR IS PROVIDED WITH THE CONTROL TO MAKE THERMOSTAT WIRE CONNECTIONS. THIS PLUG MAY BE REMOVED, WIRE CONNECTIONS MADE TO THE PLUG, AND REPLACED. IT IS STRONGLY RECOMMENDED THAT YOU DO NOT CONNECT MORE THAN TWO WIRES INTO A SINGLE TERMINAL IN THE FIELD BECAUSE THERE IS A RISK OF THE WIRES BECOMING LOOSE. WIRE NUTS ARE RECOMMENDED TO ENSURE ONE 18 AWG WIRE IS USED FOR EACH TERMINAL. FAILURE TO DO SO MAY RESULT IN INTERMITTENT OPERATION.

IMPORTANT NOTE: WHEN USING A NON-COMMUNICATING THERMOSTAT, DIP SWITCHES S1-3 MUST BE SET TO MATCH THE THERMOSTAT TYPE. WHEN USING A 2-STAGE THERMOSTAT, SET S1-3 TO ON. WHEN USING A SINGLE STAGE THERMOSTAT, SET 1-3 TO OFF. S1-4 SHOULD BE USED ONLY WHEN A SINGLE STAGE THERMOSTAT IS CONNECTED. SEE SINGLE STAGE HEATING THERMOSTAT APPLICATION SECTION FOR DETAILS.

As a two-stage non-communicating furnace, the furnace integrated control module provides terminals for both “W1” and “W2”, and “Y1” and “Y2” thermostat connections. This allows the furnace to support the following system applications: ‘Two-Stage Heating Only’, ‘Two-Stage Heating with Single Stage Cooling’, and ‘Two-Stage Heating with Two-Stage Cooling’. Refer to the following figures for proper connections to the integrated control module.

Low voltage connections can be made through either the right or left side panel. Thermostat wiring entrance holes are located in the blower compartment. The following figure shows connections for a “heat/cool system”.

This furnace is equipped with a 40 VA transformer to facilitate use with most cooling equipment. Consult the wiring diagram, located on the blower compartment door, for further details of 115 Volt and 24 Volt wiring.

NOTE: FOR SINGLE STAGE COOLING APPLICATIONS, A JUMPER MAY BE LOCATED BETWEEN Y1 AND Y2 AT THE FURNACE CONTROL IN ORDER TO ACHIEVE THE DESIRED SINGLE STAGE COOLING AIRFLOW. USE OF RAMPING PROFILES AND DEHUMIDIFICATION FEATURES REQUIRES A JUMPER BETWEEN Y1 AND O WHEN THE CONDENSING UNIT IS COOLING ONLY.

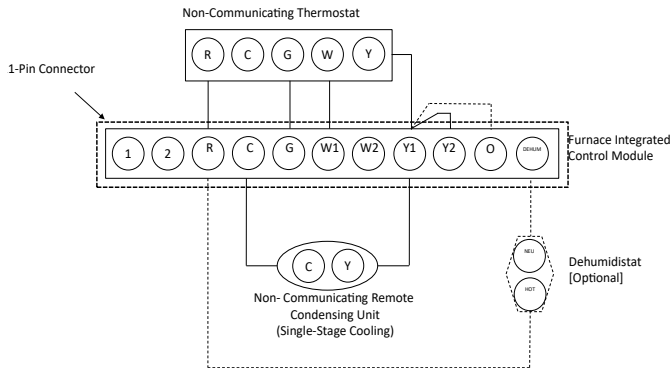

NOTE: TO APPLY A SINGLE-STAGE HEATING THERMOSTAT, THE THERMOSTAT SELECTOR SWITCH ON THE INTEGRATED CONTROL MODULE MUST BE SET ON SINGLE-STAGE.

THERMOSTAT - SINGLE -STAGE HEATING WITH SINGLE-STAGE COOLING

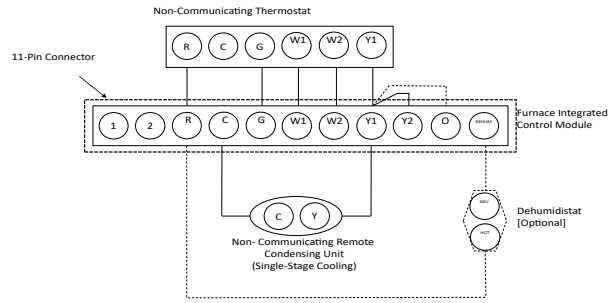

THERMOSTAT - TWO-STAGE HEATING WITH SINGLE-STAGE COOLING

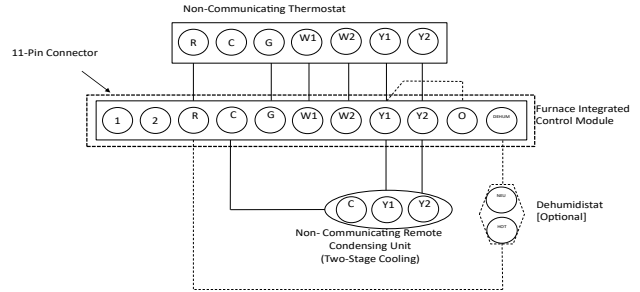

THERMOSTAT - TWO-STAGE HEATING WITH TWO-STAGE COOLING THERMOSTAT WIRING DIAGRAMS

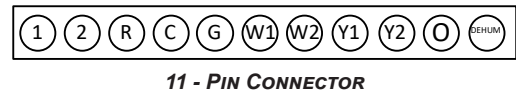

11 - PIN CONNECTOR

An 11 position low voltage connector is supplied with recent production furnaces. This connector facilitates connection to both communicating & non-communicating thermostat types. Refer to connection Diagrams.

NOTE: WHEN USING A 24 VOLT THERMOSTAT, EXERCISE CAUTION TO AVOID MAKING CONNECTIONS TO DATA 1 AND DATA 2 POSITIONS.

SINGLE-STAGE HEATING THERMOSTAT APPLICATION

A single-stage thermostat with only one heating stage may be used to control this furnace. The application of a single-stage thermostat offers a *timed* transition from low to high fire. The furnace will run on low stage for a fixed period of time before stepping up to high stage to satisfy the thermostat’s call for heat. The delay period prior to stepping up can be set at either a fixed 5 minute time delay or a load based variable time between 1 and 12 minutes (AUTO mode). If the AUTO mode is selected, the control averages the cycle times of the previous three cycles and uses the average to determine the time to transition from low stage to high stage.

To use a single-stage thermostat, turn off power to the furnace, move the thermostat selection DIP switch to the OFF position. Set the desired transition time by setting the transition delay DIP switch to the desired ON/OFF position. Turn power back on. Refer to the following figure.

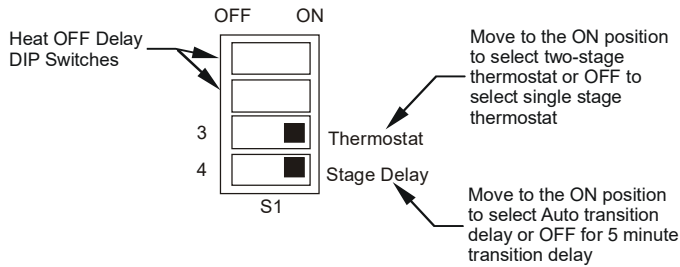

24 VOLT DEHUMIDISTAT WIRING

The optional usage of a dehumidistat allows the furnace's circulator blower to operate at a slightly lower speed (85% of desired speed) during a combined thermostat call for cooling and dehumidistat call for dehumidification. This can be done through an independent dehumidistat or through a thermostat's DEHUM terminal (if available). This lower blower speed enhances dehumidification of the conditioned air as it passes through the AC coil. For proper function, a dehumidistat applied to this furnace must operate on 24 VAC and utilize a switch which *opens on humidity rise*. Refer to the "Thermostat Wiring Diagrams" figure for additional wiring details.

To install / connect a dehumidistat:

1. Turn OFF power to furnace.
2. To enable the dehumidify function on the integrated control module, set the dehumidification ENABLE dipswitch from OFF to ON.
3. Secure the dehumidistat neutral wire (typically the white lead) to the terminal marked "DEHUM" on the furnace integrated control module.
4. Secure the dehumidistat hot wire (typically the black lead) to the terminal marked "R" on the furnace integrated control module.
5. Secure the dehumidistat ground wire (typically the green lead) to the ground screw on the furnace junction box. **NOTE:** Ground wire may not be present on all dehumidistats.
6. Turn ON power to furnace.

Once the switch is set, the dehumidify function is enabled during a *combination* call for cooling (T-Stat) and dehumidification (DEHUM-Stat).

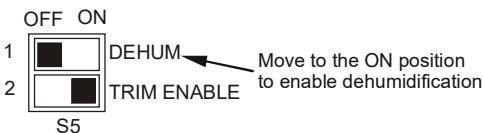

FOSSIL FUEL APPLICATIONS

This furnace can be used in conjunction with a heat pump in a fossil fuel application. A fossil fuel application refers to a combined gas furnace and heat pump installation which uses an outdoor temperature sensor to determine the most cost efficient means of heating (heat pump or gas furnace).

A heat pump thermostat with *three stages of heat* is required to properly use a two-stage furnace in conjunction with a heat pump. Refer to the fossil fuel kit installation instructions for additional thermostat requirements.

Strictly follow the wiring guidelines in the fossil fuel kit installation instructions. All furnace connections must be made to the furnace two-stage integrated control module and the "FURNACE" terminal strip on the fossil fuel control board.

115 VOLT LINE CONNECTION OF ACCESSORIES (HUMIDIFIER AND ELECTRONIC AIR CLEANER)

WARNING

HIGH VOLTAGE
TO AVOID PERSONAL INJURY OR DEATH DUE TO ELECTRICAL SHOCK, DISCONNECT ELECTRICAL POWER BEFORE SERVICING OR CHANGING ANY ELECTRICAL WIRING.

The furnace integrated control module is equipped with line voltage accessory terminals for controlling power to an optional field-supplied humidifier and/or electronic air cleaner.

The accessory load specifications are as follows:

Humidifier	1.0 Amp maximum at 120 VAC
Electronic Air Cleaner	1.0 Amp maximum at 120 VAC

Turn OFF power to the furnace before installing any accessories. Follow the humidifier or air cleaner manufacturers' instructions for locating, mounting, grounding, and controlling these accessories. Accessory wiring connections are to be made through the 1/4" quick connect terminals provided on the furnace integrated control module. The Electronic air cleaner hot terminal is identified as EAC. *It is necessary to remove the protective tab on the board cover to access the EAC Terminal.* The EAC neutral terminal is identified as NEUTRAL. A line voltage humidifier may be connected between one of the HUM contacts and NEUTRAL. The other HUM contact must be fed from the L1 terminal.

All field wiring must conform to applicable codes. Connections should be made as shown in the following figure.

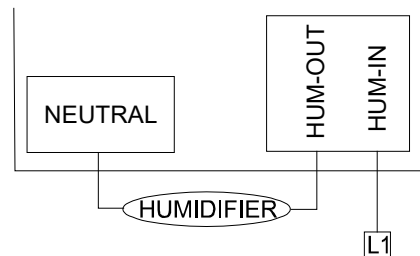
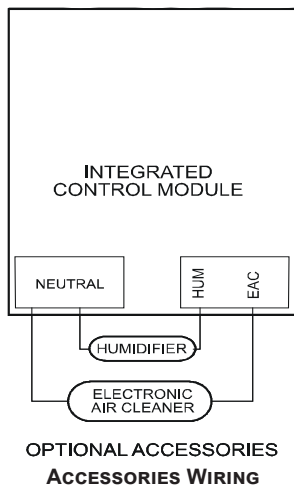

24 VOLT HUMIDIFIER

A 24 volt humidifier can be powered by feeding one of the HUM terminals with a field installed wire from the R terminal or by connecting to the NO side of the low fire pressure switch.

AUXILIARY ALARM SWITCH

The control is equipped with a 24VAC Auxiliary Alarm Input (12 inch purple wire attached to pin 6 of 15 pin connector) which can be utilized with communicating mode setups (typically used for condensate switch wiring but could be used with compatible CO₂ sensors or Fire Alarms).

Legacy mode use

In a legacy system (Non-communicating), this auxiliary alarm input is not operational. Any auxiliary alarm switch must be used to interrupt Y1 signal either to IFC or to UC.

Communication mode use

This feature can be activated or deactivated through the thermostat user menus. By default, an AUX switch is normally closed and opens when the water level in the evaporator coil base pan reaches a particular level. The control will respond by turning off the outdoor compressor and display the proper fault codes. If the AUX switch is detected closed for 30 seconds, normal operation resumes and error messages are no longer displayed. Installer must wire control voltage (24VAC) to AUX switch to ensure the Auxiliary Alarm Input has 24 VAC during normal operation.

GAS SUPPLY AND PIPING

The furnace rating plate includes the approved furnace gas input rating and gas types. The furnace must be equipped to operate on the type of gas applied. This includes any conversion kits required for alternate fuels and/or high altitude.

 CAUTION
<p>TO PREVENT UNRELIABLE OPERATION OR EQUIPMENT DAMAGE, THE INLET GAS SUPPLY PRESSURE MUST BE AS SPECIFIED ON THE UNIT RATING PLATE WITH ALL OTHER HOUSEHOLD GAS FIRED APPLIANCES OPERATING.</p>

If it is necessary for the installer to supply additional line voltage wiring to the inside of the furnace, the wiring must conform to all local codes, and have a minimum temperature rating of 105°C. All line voltage wire splices must be made inside the furnace junction box.

The integrated control module single humidifier terminal (HUM) is energized with 115 volts whenever the induced draft blower is energized. This terminal can also be used to provide 115 volt power to a humidifier transformer. The remaining primary transformer wire would be connected to the Line N on the control board. The integrated control module electronic air cleaner terminal (EAC) is energized with 115 volts whenever the circulator blower is energized.

In addition, the control is equipped with a dedicated humidification relay which is available through ¼ inch terminals HUM-IN and HUM-OUT. Similar to the HUM terminal, when utilizing legacy connections, this relay will be closed during normal heating operation. HUM IN must be powered with the desired voltage (24 vac from the R terminal or 115 vac from L1 terminal). The internal relay will close during a call for heat. Also, the control can provide additional humidification features when wired to a communicating thermostat (1, 2, R, C connections). If the communicating thermostat is not capable of providing a humidification call, this dedicated relay will function exactly as mentioned above with a legacy setup. If the communicating thermostat is capable of providing a humidification call the user is now provided with 3 modes of operations which can be selected within the thermostat user menu.

1. ON: Humidifier is turned on with a heat demand.
2. OFF: Humidifier remains off (relay never closes).
3. IND: Humidifier will cycle with humidification demand, independent of heat demand. This mode allows the user to select one of 4 fan speeds (25, 50, 75, and 100%).

Inlet gas supply pressures must be maintained within the ranges specified in the following table. The supply pressure must be constant and available with all other household gas fired appliances operating. The minimum gas supply pressure must be maintained to prevent unreliable ignition. The maximum must not be exceeded to prevent unit overfiring.

NOTE: Do NOT REMOVE THE GAS VALVE INLET PLUG BEFORE THE GAS LINE IS INSTALLED. REPLACE IF WATER OR DEBRIS HAS BEEN INTRODUCED.

INLET GAS SUPPLY PRESSURE		
Natural Gas	Minimum: 4.5" w.c.	Maximum: 10.0" w.c.
Propane Gas	Minimum: 11.0" w.c.	Maximum: 13.0" w.c.

NOTE: ADJUSTING THE MINIMUM SUPPLY PRESSURE BELOW THE LIMITS IN THE ABOVE TABLE COULD LEAD TO UNRELIABLE IGNITION. GAS INPUT TO THE BURNERS MUST NOT EXCEED THE RATED INPUT SHOWN ON THE RATING PLATE. OVERFIRING OF THE FURNACE CAN RESULT IN PREMATURE HEAT EXCHANGER FAILURE. GAS PRESSURES IN EXCESS OF 13 INCHES WATER COLUMN CAN ALSO CAUSE PERMANENT DAMAGE TO THE GAS VALVE.

At all altitudes, the manifold pressure must be within 0.3 inches w.c. of that listed in the Specification Sheet applicable to your model for the fuel used. At all altitudes and with either fuel, the air temperature rise must be within the range listed on the furnace nameplate. Should this appliance be converted to LP, refer to the instructions included in the factory authorized LP conversion kit.

HIGH ALTITUDE DERATE

High altitude installations may require both a pressure switch and an orifice change. These changes are necessary to compensate for the natural reduction in the density of both the gas fuel and the combustion air at higher altitude.

For installations above 5500 feet, please refer to your distributor for required kit(s).

Gas	Altitude	Kit	Orifice	Manifold Pressure		Pressure Switch Change
				High Stage	Low Stage	
Natural	0-5500	None	#45	3.5" w.c.	1.9" w.c.	None
Propane		LPM-06	#55	10.0" w.c.	6.0" w.c.	None

Consult the furnace Specification Sheet for appropriate manufacturer's kits for propane gas and/or high altitude installations. The indicated kits must be used to insure safe and proper furnace operation. All conversions must be performed by a qualified installer, or service agency.

PROPANE GAS CONVERSION

 WARNING
<p>POSSIBLE PROPERTY DAMAGE, PERSONAL INJURY OR DEATH MAY OCCUR IF THE CORRECT CONVERSION KITS ARE NOT INSTALLED. THE APPROPRIATE KITS MUST BE APPLIED TO ENSURE SAFE AND PROPER FURNACE OPERATION. ALL CONVERSIONS MUST BE PERFORMED BY A QUALIFIED INSTALLER OR SERVICE AGENCY.</p>

This unit is configured for natural gas. The appropriate manufacturer's propane gas conversion kit, must be applied for propane gas installations.

If converting to LP gas, it is recommended that an LPLP0* kit also be installed. The use of this kit will prevent the furnace from firing when the LP gas supply pressure is too low to support proper combustion.

GAS PIPING CONNECTIONS

 WARNING
<p>TO AVOID POSSIBLE UNSATISFACTORY OPERATION OF EQUIPMENT DAMAGE DUE TO UNDERFIRING OR EQUIPMENT, USE THE PROPER SIZE OF NATURAL/PROPANE GAS PIPING NEEDED WHEN RUNNING PIPE FROM THE METER/TANK TO THE FURNACE.</p>

When sizing gas lines, be sure to include all appliances which will operate simultaneously.

The gas piping supplying the furnace must be properly sized based on the gas flow required, specific gravity of the gas, and length of the run. The gas line installation must comply with local codes, or in their absence, with the latest edition of the National Fuel Gas Code, NFPA 54/ANSI Z223.1.

**Natural Gas Capacity of Pipe
In Cubic Feet of Gas Per Hour (CFH)**

Length of Pipe in Feet	Nominal Black Pipe Size				
	1/2"	3/4"	1"	1 1/4"	1 1/2"
10	132	278	520	1050	1600
20	92	190	350	730	1100
30	73	152	285	590	980
40	63	130	245	500	760
50	56	115	215	440	670
60	50	105	195	400	610
70	46	96	180	370	560
80	43	90	170	350	530
90	40	84	160	320	490
100	38	79	150	305	460

(Pressure 0.5 psig or less and pressure drop of 0.3" W.C.; Based on 0.60 Specific Gravity Gas)

$$CFH = \frac{BTUH \text{ Furnace Input}}{\text{Heating Value of Gas (BTU/Cubic Foot)}}$$

To connect the furnace to the building's gas piping, the installer must supply a ground joint union, drip leg, manual shutoff valve, and line and fittings to connect to gas valve. In some cases, the installer may also need to supply a transition piece from 1/2" pipe to a larger pipe size.

The following stipulations apply when connecting gas piping.

- Gas piping must be supported external to the furnace cabinet so that the weight of the gas line does not distort the burner rack, manifold or gas valve.
- Use black iron or steel pipe and fittings for the building piping.
- Use pipe joint compound on male threads only. Pipe joint compound must be resistant to the action of the fuel used.
- Use ground joint unions.
- Install a drip leg to trap dirt and moisture before it can enter the gas valve. The drip leg must be a minimum of three inches long.
- Use two pipe wrenches when making connection to the gas valve to keep it from turning. The orientation of the gas valve on the manifold must be maintained as shipped from the factory.
- Install a manual shutoff valve between the gas meter and unit within six feet of the unit. If a union is installed, the union must be downstream of the manual shutoff valve, between the shutoff valve and the furnace.
- Tighten all joints securely.
- Connect the furnace to the building piping by one of the following methods:
 - Rigid metallic pipe and fittings.
 - Semi-rigid metallic tubing and metallic fittings. Aluminum alloy tubing must not be used in exterior locations.
 - Use listed gas appliance connectors in accordance with their instructions. Connectors must be fully in the same room as the furnace.
 - Protect connectors and semi-rigid tubing against physical and thermal damage when installed. Ensure aluminum-alloy tubing and connectors are coated to protect against external corrosion when in contact with masonry, plaster, or insulation, or subjected to repeated wetting by liquids such as water (except rain water), detergents, or sewage.

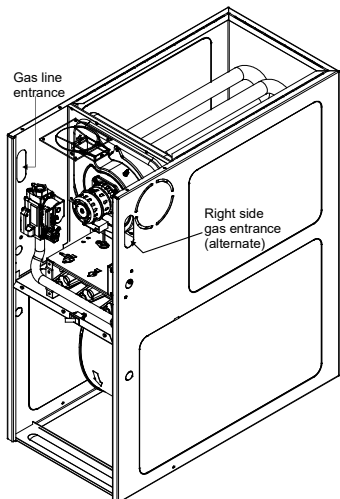

GENERAL FURNACE LAYOUT

UPFLOW INSTALLATIONS

When the gas piping enters through the side of the furnace, the installer must supply the following fittings (starting from the gas valve):

- Close nipple.
- 90 degree elbow.
- Straight pipe to reach the exterior of the furnace.

A ground joint union, drip leg, and manual shutoff valve must also be supplied by the installer. In some cases, the installer may also need to supply a transition piece from 1/2" to another pipe size.

When the gas piping enters through the left side of the furnace, the installer must supply the following fittings (starting from the gas valve):

- 90 degree elbow.
- Straight pipe to reach the exterior of the furnace.
- A ground joint union, drip leg, and manual shutoff valve must also be supplied by the installer. In some cases, the installer may also need to supply a transition piece from 1/2 inch to another pipe size.

COUNTERFLOW INSTALLATIONS

When the gas piping enters through the left side of the furnace, the installer must supply a straight pipe and a 90 degree elbow to reach the exterior of the furnace.

A ground joint union, drip leg and manual shutoff valve must also be supplied by the installer. In most cases, the installer may also need to supply a transition piece from 1/2" to another pipe size. When the gas piping enters through the right side of the furnace, the installer must supply the following fittings (starting at the gas valve):

- Close Nipple
- 90 Degree Elbow
- Straight Pipe to Reach Exterior of Furnace.

GAS PIPING CHECKS

Before placing unit in operation, leak test the unit and gas connections.

 <b style="font-size: 1.2em;">WARNING
<p>TO AVOID THE POSSIBILITY OF EXPLOSION OR FIRE, NEVER USE A MATCH OR OPEN FLAME TO TEST FOR LEAKS.</p>

Check for leaks using an approved chloride-free soap and water solution, an electronic combustible gas detector, or other approved testing methods.

 <b style="font-size: 1.2em;">CAUTION
<p>TO PREVENT PROPERTY DAMAGE OR PERSONAL INJURY DUE TO FIRE, THE FOLLOWING INSTRUCTIONS MUST BE PERFORMED REGARDING GAS CONNECTIONS, PRESSURE TESTING, LOCATION OF SHUTOFF VALVE AND INSTALLATION OF GAS PIPING.</p>

NOTE: NEVER EXCEED SPECIFIED PRESSURES FOR TESTING. HIGHER PRESSURE MAY DAMAGE THE GAS VALVE AND CAUSE SUBSEQUENT OVERFIRING, RESULTING IN HEAT EXCHANGER FAILURE.

Disconnect this unit and shutoff valve from the gas supply piping system before pressure testing the supply piping system with pressures in excess of ½ psig (3.48 kPa). This unit must be isolated from the gas supply system by closing its manual shutoff valve before pressure testing of gas supply piping system with test pressures equal to or less than ½ psig (3.48 kPa).

PROPANE GAS TANKS AND PIPING

WARNING

IF THE GAS FURNACE IS INSTALLED IN A BASEMENT, AN EXCAVATED AREA OR CONFINED SPACE, IT IS STRONGLY RECOMMENDED TO CONTACT A PROPANE SUPPLIER TO INSTALL A GAS DETECTING WARNING DEVICE IN CASE OF A GAS LEAK.

- **SINCE PROPANE GAS IS HEAVIER THAN AIR, ANY LEAKING GAS CAN SETTLE IN ANY LOW AREAS OR CONFINED SPACES.**
- **PROPANE GAS ODORANT MAY FADE, MAKING THE GAS UNDETECTABLE EXCEPT WITH A WARNING DEVICE.**

A gas detecting warning system is the only reliable way to detect a propane gas leak. Rust can reduce the level of odorant in propane gas. Do not rely on your sense of smell. Contact a local propane gas supplier about installing a gas detecting warning system. If the presence of gas is suspected, follow the instructions on Page 3 of this manual. All propane gas equipment must conform to the safety standards of the National Board of Fire Underwriters, NBFU Manual 58.

For satisfactory operation, propane gas pressure must be 10 inch WC at the furnace manifold with all gas appliances in operation. Maintaining proper gas pressure depends on three main factors:

1. Vaporization rate, depending on temperature of the liquid, and “wetted surface” area of the container or containers.
2. Proper pressure regulation (Two-stage regulation is recommended for both cost and efficiency).
3. Pressure drop in lines between regulators, and between second stage regulator and the appliance. Pipe size will depend on length of pipe run and total load of all appliances.

Complete information regarding tank sizing for vaporization, recommended regulator settings, and pipe sizing is available from most regulator manufacturers and propane gas suppliers.

Use a pipe thread compound that is approved for natural gas and LP Gas.

Refer to the following illustration for typical propane gas installations and piping.

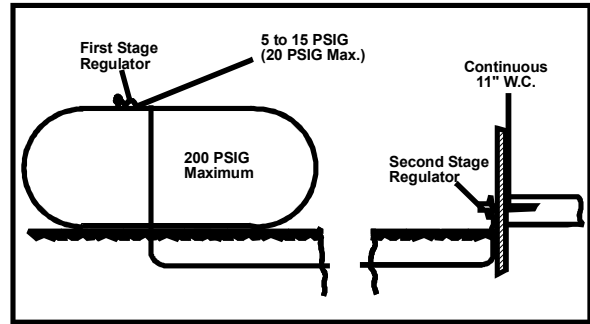

PROPANE GAS INSTALLATION (TYP.)

PROPANE GAS PIPING CHARTS

Sizing Between First and Second Stage Regulator*
 Maximum Propane Capacities listed are based on 2 psig pressure drop at 10 psig setting. Capacities in 1,000 BTU/hour.

Pipe or Tubing Length, Feet	Tubing Size, O.D. Type L					Nominal Pipe Size Schedule 40	
	3/8"	1/2"	5/8"	3/4"	7/8"	1/2"	3/4"
10	730	1,700	3,200	5,300	8,300	3,200	7,500
20	500	1,100	2,200	3,700	5,800	2,200	4,200
30	400	920	2,000	2,900	4,700	1,800	4,000
40	370	850	1,700	2,700	4,100	1,600	3,700
50	330	770	1,500	2,400	3,700	1,500	3,400
60	300	700	1,300	2,200	3,300	1,300	3,100
80	260	610	1,200	1,900	2,900	1,200	2,600
100	220	540	1,000	1,700	2,600	1,000	2,300
125	200	490	900	1,400	2,300	900	2,100
150	190	430	830	1,300	2,100	830	1,900
175	170	400	780	1,200	1,900	770	1,700
200	160	380	730	1,100	1,800	720	1,500

Sizing Between Second Stage and Appliance Regulator*
 Maximum Propane Capacities listed are based on 2 psig pressure drop at 10 psig setting. Capacities in 1,000 BTU/hour.

Pipe or Tubing Length, Feet	Tubing Size, O.D. Type L						Nominal Pipe Size Schedule 40				
	3/8"	1/2"	5/8"	3/4"	7/8"	1-1/8"	1/2"	3/4"	1"	1-1/4"	1-1/2"
10	39	92	199	329	501	935	275	567	1,071	2,205	3,307
20	26	62	131	216	346	630	189	393	732	1,496	2,299
30	21	50	107	181	277	500	152	315	590	1,212	1,858
40	19	41	90	145	233	427	129	267	504	1,039	1,559
50	18	37	79	131	198	376	114	237	448	910	1,417
60	16	35	72	121	187	340	103	217	409	834	1,275
80	13	29	62	104	155	289	89	185	346	724	1,066
100	11	26	55	90	138	255	78	162	307	630	976
125	10	24	48	81	122	224	69	146	275	567	866
150	9	21	43	72	109	202	63	132	252	511	787
200	8	19	39	66	100	187	54	112	209	439	665
250	8	17	36	60	93	172	48	100	185	390	590

CIRCULATING AIR

WARNING

NEVER ALLOW THE PRODUCTS OF COMBUSTION, INCLUDING CARBON MONOXIDE TO ENTER THE RETURN DUCT WORK OR CIRCULATION AIR SUPPLY.

Duct systems and register sizes must be properly designed for the CFM and external static pressure rating of the furnace. Ductwork should be designed in accordance with the recommended methods of “Air Conditioning Contractors of America” Manual D.

A duct system must be installed in accordance with Standards of the National Board of Fire Underwriters for the Installation of Air Conditioning, Warm Air Heating and Ventilating Systems. Pamphlets No. 90A and 90B.

A closed return duct system must be used, with the return duct connected to the furnace. **NOTE: Ductwork must never be attached to the back of the furnace.** For installations requiring more than 1800 CFM, use a bottom return or two sided return. Supply and return connections to the furnace may be made with flexible joints to reduce noise transmission. To prevent the blower from interfering with combustion air or draft when a central return is used, a connecting duct must be installed between the unit and the utility room wall. A room, closet, or alcove must not be used as a return air chamber.

When the furnace is used in connection with a cooling unit, the furnace should be installed in parallel with or on the upstream side of the cooling unit to avoid condensation in the heating element. With a parallel flow arrangement, the dampers or other means used to control the flow of air must be adequate to prevent chilled air from entering the furnace and, if manually operated, must be equipped with means to prevent operation of either unit unless the damper is in the full heat or cool position.

When the furnace is installed without a cooling coil, it is recommended that a removable access panel be provided in the outlet air duct. This opening shall be accessible when the furnace is installed and shall be of such a size that the heat exchanger can be viewed for visual light inspection or such that a sampling probe can be inserted into the airstream. The access panel must be made to prevent air leaks when the furnace is in operation.

When the furnace is heating, the temperature of the return air entering the furnace must be between 55°F and 100°F.

When a furnace is installed so that supply ducts carry air circulated by the furnace to areas outside the space containing the furnace, the return air shall also be handled by a duct sealed to the furnace casing and terminating outside the space containing the furnace.

CHECKING DUCT STATIC

Refer to your furnace rating plate for the maximum ESP (external duct static) rating.

Total external static refers to everything external to the furnace cabinet. Cooling coils, filters, ducts, grilles, registers must all be considered when reading your total external static pressure. The supply duct pressure must be read between the furnace and the cooling coil. This reading is usually taken by removing the "A" shaped block off plate from the end on the coil; drilling a test hole in it and reinstalling the block off plate. Take a duct static reading at the test hole. Tape up the test hole after your test is complete. The negative pressure must be read between the filter and the furnace blower.

Too much external static pressure will result in insufficient air that can cause excessive temperature rise. This can cause limit switch tripping and heat exchanger failure.

To determine total external duct static pressure, proceed as follows:

1. With clean filters in the furnace, use a manometer to measure the static pressure of the return duct at the inlet of the furnace. (Negative Pressure)
2. Measure the static pressure of the supply duct. (Positive Pressure)
3. The difference between the two numbers is .4" w.c.

Example:

static reading from return duct = -.1" w.c.

static reading from supply duct = .3" w.c.

total external static pressure on this system = .4" w.c.

NOTE: BOTH READINGS MAY BE TAKEN SIMULTANEOUSLY AND READ DIRECTLY ON THE MANOMETER IF SO DESIRED. IF AN AIR CONDITIONER COIL OR ELECTRONIC AIR CLEANER IS USED IN CONJUNCTION WITH THE FURNACE, THE READINGS MUST ALSO INCLUDE THESE COMPONENTS, AS SHOWN IN THE FOLLOWING DRAWING.

4. Consult proper tables for the quantity of air.

If the total external static pressure exceeds the maximum listed on the furnace rating plate, check for closed dampers, registers, undersized or poorly laid out duct work.

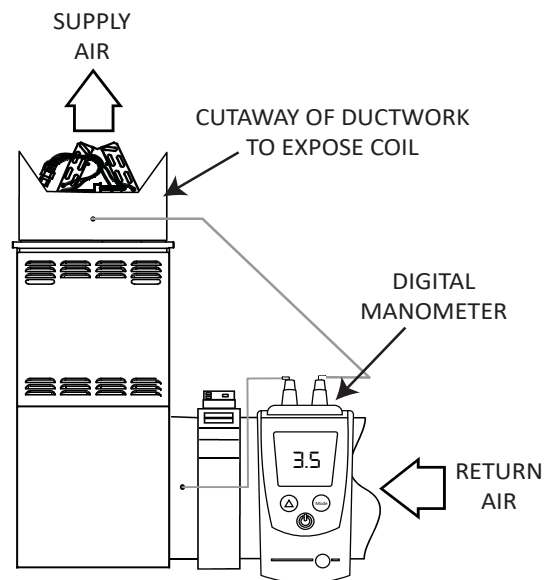

CHECKING STATIC PRESSURE

FILTERS - READ THIS SECTION BEFORE INSTALLING THE RETURN AIR DUCTWORK

Filters must be used with this furnace. Discuss filter maintenance with the building owner. Filters do not ship with this furnace, but must be provided by the installer. Filters must comply with UL900 or CAN/ULCS111 standards. Damage or repairs due to the installation of the furnace without filters is not covered under the warranty.

UPRIGHT INSTALLATIONS

Depending on the installation and/or customer preference, differing filter arrangements can be applied. Filters can be installed in the central return register or a side panel external filter rack kit (upflows), or the ductwork above a downflow furnace. As an alternative, a media air filter or electronic air cleaner can be used as the primary filter.

HORIZONTAL INSTALLATIONS

Filters must be installed in either the central return register or in the return air duct work.

CIRCULATION AIR FILTERS

One of the most common causes of a problem in a forced air heating system is a blocked or dirty filter. Circulating air filters must be inspected monthly for dirt accumulation and replaced if necessary. Failure to maintain clean filters can cause premature heat exchanger failure.

A new home may require more frequent replacement until all construction dust and dirt is removed.

Upflow / Horizontal Models	Minimum Recommended Filter Size^
DM80VC0603B*	1 - 16 X 25 Side or 1 - 14 X 24 Bottom Return
DM80VC0604B*	1 - 16 X 25 Side or 14 X 24 Bottom Return
DM80VC0803B*	1 - 16 X 25 Side or Bottom Return
DM80VC0804C*	1 - 16 X 25 Side or Bottom Return
DM80VC0805C*1	1 - 16 X 25 Side or Bottom Return ¹
DM80VC0805D*1	1 - 16 X 25 Side or Bottom Return ¹
DM80VC1005C*	2 - 16 X 25 Side or 1 - 20 X 25 Bottom Return
Downflow / Horizontal Models	
DC80VC0603B*	2 - 10 X 20 or 1 - 16 X 25 Top Return
DC80VC0803B*	2 - 10 X 20 or 1 - 16 X 25 Top Return
DC80VC0805C*	2 - 14 X 20 or 1 - 20 X 25 Top Return
DC80VC1005C*	2 - 14 X 20 or 1 - 20 X 25 Top Return

^ Larger filters may be used, filters may also be centrally located

1 = use 2 - 16 X 25 filters and two side returns or 20 X 25 filter on bottom return if furnace is connected to a cooling unit over 4 tons nominal capacity

Consider installing an air cleaner with deep-pleated media filter at the time of furnace installation. A deep-pleated filter with a MERV rating of 8 (minimum) will often provide better filtration to protect equipment and the air distribution system than a standard 1" filter and often has lower static pressure loss than a 1" filter. Also a deep-pleated filter will typically require less frequent replacement intervals. Avoid using highly restrictive 1" filters which produce static pressure loss greater than .25" W.C. In some installations the minimum filter size required (consult filter sizing chart) will not lend itself to a filter installation on the side of the furnace. The installation of a centrally installed air cleaner cabinet or a return duct filter installation may offer more practicality.

The Daikin MERV 15 air cleaner is available in the following configurations. Treats home air for airborne particulate matter found in the home. The high efficiency

MERV 15 media filter removes more than 85% of particles down to 0.3 microns in size at 492 fpm.

Visit www.daikincomfort.com for more information on our complete line of Daikin AIQ products.



START-UP PROCEDURE AND ADJUSTMENT

Furnace must have a 115 VAC power supply properly connected and grounded. Proper polarity must be maintained for correct operation. In addition to the following start-up and adjustment items, refer to further information in *Operational Checks* section.

FURNACE OPERATION

Purge gas lines of air prior to startup. Be sure not purge lines into an enclosed burner compartment.

Check for leaks using an approved chloride-free soap and water solution, an electronic combustible gas detector, or other approved method. Verify that all required kits (propane gas, high altitude, etc.) have been appropriately installed.

FURNACE STARTUP

1. Close the manual gas shutoff valve external to the furnace.
2. Turn off the electrical power to the furnace.
3. Set the room thermostat to the lowest possible setting.
4. Remove the burner compartment door.

NOTE: THIS FURNACE IS EQUIPPED WITH AN IGNITION DEVICE WHICH AUTOMATICALLY LIGHTS THE BURNER. DO NOT TRY TO LIGHT THE BURNER BY HAND.

5. Move the furnace gas valve manual control to the OFF position.
6. Wait five minutes then smell for gas. Be sure check near the floor as some types of gas are heavier than air.
7. If you smell gas after five minutes, immediately follow the instructions in the *Safety Instructions* section of this manual. If you do not smell gas after five minutes, move the furnace gas valve manual control to the ON position.

8. Replace the burner compartment door.
9. Open the manual gas shutoff valve external to the furnace.
10. Turn on the electrical power to the furnace.
11. Adjust the thermostat to a setting above room temperature.
12. After the burners are lit, set the thermostat to desired temperature.

FURNACE SHUTDOWN

1. Set the thermostat to the lowest setting.
The integrated control will close the gas valve and extinguish flame. Following a 15 second delay, the induced draft blower will be de-energized. After a 120, 150, 180 or 210-second delay period (field selectable delay OFF [90, 120, 150, 180] plus 30-second ramp down), the circulator blower de-energizes.
2. Remove the burner compartment door and move the furnace gas valve manual control to the OFF position.
3. Close the manual gas shutoff valve external to the furnace.
4. Replace the burner compartment door.

GAS SUPPLY PRESSURE MEASUREMENT

GAS PRESSURE TEST

This test is to be used for field test mode only, and it will allow gas valve pressure to be checked at 100% firing rate.

1. If both 'FAULT RECALL' and 'LEARN' push buttons are pressed for greater than 1 second, the display will blank to indicate the push buttons are pressed. Within 5 seconds, both push buttons should be released. If any push button is not released, the test mode will not activate. The display will return to normal.
2. Once the push buttons are released, the display will flash "Ft" to indicate the push buttons are released and successful entry into test mode has been achieved.
3. The control will force a high capacity demand. If a low capacity demand is already being serviced, it will be forced to high capacity.
4. The display will continue to flash "Ft" until high capacity (100%) is achieved. Once achieved, the display will show "Ft" without flashing. A 5-minute timer will be started to allow sufficient opportunity for the gas pressure to be tested.
5. If a call for heat is given or removed during the test, the system will still operate until the 5 minute test time is complete.
6. During test mode, if both push buttons are pressed for greater than 1 second, the display will blank to indicate push buttons are pressed. If both push buttons are released within 5 seconds, the test mode will terminate and the system will return to normal operation. Otherwise, the test mode will continue uninterrupted.
7. After completion of the 5-minute timer or test mode termination, whichever is earlier, the system will return to normal operation, either continuing an existing heat demand or going to the idle state.

CAUTION

TO PREVENT UNRELIABLE OPERATION OR EQUIPMENT DAMAGE, THE INLET GAS SUPPLY PRESSURE MUST BE AS SPECIFIED ON THE UNIT RATING PLATE WITH ALL OTHER HOUSEHOLD GAS FIRED APPLIANCES OPERATING.

The line pressure supplied to the gas valve must be within the range specified below. The supply pressure can be measured at the gas valve inlet pressure tap or at a hose fitting installed in the gas piping drip leg. The supply pressure must be measured with the burners operating. To measure the gas supply pressure, use the following procedure.

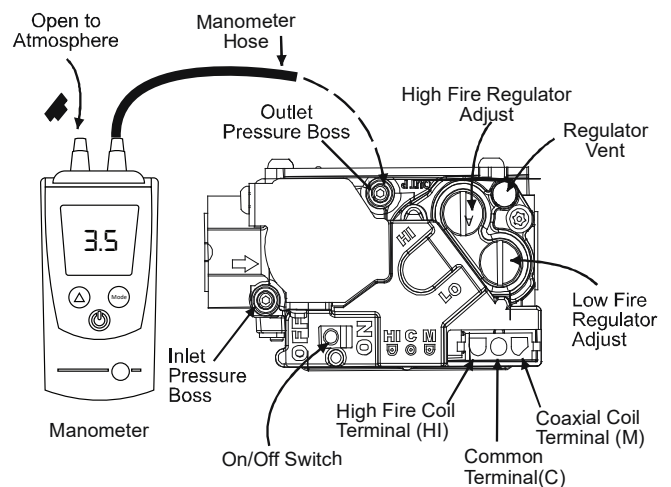
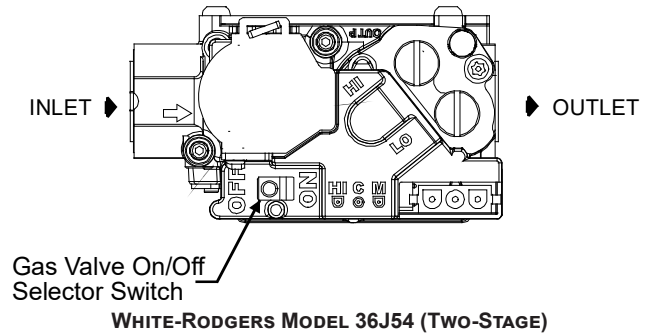

1. Turn OFF gas to furnace at the manual gas shutoff valve external to the furnace.
2. Connect a calibrated manometer (or appropriate gas pressure gauge) at the gas valve inlet pressure tap. See White-Rodgers gas valve figure for location of inlet pressure tap.

NOTE: IF USING THE INLET PRESSURE TAP ON THE WHITE-RODGERS GAS VALVE, THEN USE THE 36G/J VALVE PRESSURE CHECK KIT, PART No. 0151K00000S.

3. Turn ON the gas supply and operate the furnace and all other gas consuming appliances on the same gas supply line.
4. Measure furnace gas supply pressure with burners firing. Supply pressure must be within the range specified in the *Inlet Gas Supply Pressure* table.

INLET GAS SUPPLY PRESSURE		
Natural Gas	Minimum: 4.5" w.c.	Maximum: 10.0" w.c.
Propane Gas	Minimum: 11.0" w.c.	Maximum: 13.0" w.c.

If supply pressure differs from table, make the necessary adjustments to pressure regulator, gas piping size, etc., and/or consult with local gas utility.

- Turn OFF gas to furnace at the manual shutoff valve and disconnect manometer. Reinstall plug before turning on gas to furnace.
- Turn OFF any unnecessary gas appliances stated in step 3.

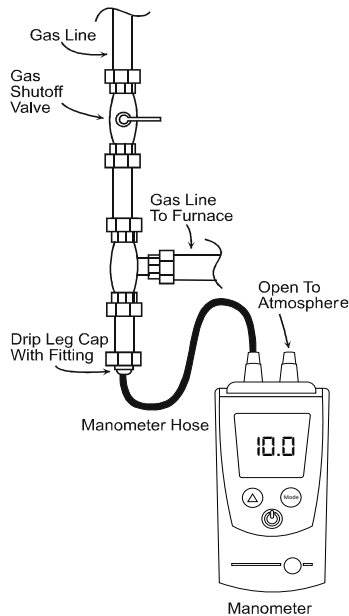

MEASURING INLET GAS PRESSURE (ALT. METHOD)

GAS MANIFOLD PRESSURE MEASUREMENT AND ADJUSTMENT



CAUTION

TO PREVENT UNRELIABLE OPERATION OR EQUIPMENT DAMAGE, THE GAS MANIFOLD PRESSURE MUST BE AS SPECIFIED ON THE UNIT RATING PLATE. ONLY MINOR ADJUSTMENT SHOULD BE MADE BY ADJUSTING THE GAS VALVE PRESSURE REGULATOR.

Only small variations in gas pressure should be made by adjusting the gas valve pressure regulator. The manifold pressure must be measured with the burners operating. To measure and adjust the manifold pressure, use the following procedure.

- Turn OFF gas to furnace at the manual gas shutoff valve external to the furnace.
- Turn off all electrical power to the system.
- Outlet pressure tap connections: Back outlet pressure test screw (inlet/outlet pressure boss) out one turn (counterclockwise, not more than one turn).
- Attach a hose and manometer to the outlet pressure tap (White-Rodgers valve).
- Turn ON the gas supply.
- Turn on power and close thermostat "R" and "W1" contacts to provide a call for low stage heat.

- Measure the gas manifold pressure with burners firing. Adjust manifold pressure using the *Manifold Gas Pressure* table shown below.
- Remove regulator cover screw from the low (LO) outlet pressure regulator adjust tower and turn screw clockwise to increase pressure or counterclockwise to decrease pressure. Replace regulator cover screw.
- Close thermostat "R" and "W2" contacts to provide a call for high stage heat.
- Remove regulator cover screw from the high (HI) outlet pressure regulator adjust tower and turn screw clockwise to increase pressure or counterclockwise to decrease pressure. Replace regulator cover screw.
- Turn off all electrical power and gas supply to the system.
- Remove the manometer hose from the hose barb fitting or outlet pressure tap.
- Replace outlet pressure tap: White-Rodgers valve: Turn outlet pressure test screw in to seal pressure port (clockwise, 7 in-lb minimum).
- Turn on electrical power and gas supply to the system.
- Close thermostat contacts "R" and "W1/W2" to energize the valve.

Using a leak detection solution or soap suds, check for leaks at outlet pressure screw (White-Rodgers valve). Bubbles forming indicate a leak. SHUT OFF GAS AND REPAIR ALL LEAKS IMMEDIATELY!

NOTE: FOR GAS TO GAS CONVERSION, CONSULT YOUR DEALER FOR APPROPRIATE CONVERSION.

Manifold Gas Pressure			
Gas		Range	Nominal
Natural	Low Stage	1.6 - 2.2" w.c.	1.9" w.c.
	High Stage	3.2 - 3.8" w.c.	3.5" w.c.
Propane	Low Stage	5.7 - 6.3" w.c.	6.0" w.c.
	High Stage	9.7 - 10.3" w.c.	10.0" w.c.

- Determine the tonnage of the cooling system installed with the furnace. If the cooling capacity is in BTU/hr divide it by 12,000 to convert capacity to TONS.
Example: Cooling Capacity of 30,000 BTU/hr.

GAS INPUT RATE MEASUREMENT (NATURAL GAS ONLY)

The gas input rate to the furnace must never be greater than that specified on the unit rating plate. To measure natural gas input using the gas meter, use the following procedure.

- Turn OFF the gas supply to all other gas-burning appliances except the furnace.
- While the furnace is operating, time and record one complete revolution of the smallest gas meter dial.
- Calculate the number of seconds per cubic foot (sec/ft³) of gas being delivered to the furnace. If the dial is a two cubic foot dial, divide the number of seconds recorded in step 2 by two.
- Calculate the furnace input in BTUs per hour (BTU/hr). Input equals the sum of the installation's gas heating value and a conversion factor (hours to

seconds) divided by the number of seconds per cubic foot. The measured input must not be greater than the input indicated on the unit rating plate.

EXAMPLE:

Installation's gas heating (HTG) value: 1,000 BTU/ft³
(Obtained from gas supplier)

Installation's seconds per cubic foot: 34 sec/ ft³
 Conversion Factor (hours to seconds): 3600 sec/hr
 Input = (Htg. value x 3600) ÷ seconds per cubic foot
 Input = (1,000 BTU/ft³ x 3600 sec/hr) ÷ 34 sec/ ft³
 Input = 106,000 BTU/hr
 Minor changes to the input rate may be accomplished through manifold pressure adjustments at the gas valve.

NOTE: THE FINAL MANIFOLD PRESSURE CANNOT VARY BY MORE THAN ± 0.3" W.C. FROM THE SPECIFIED SETTING. CONSULT YOUR LOCAL GAS SUPPLIER IF ADDITIONAL INPUT RATE ADJUSTMENT IS REQUIRED.

5. Repeat steps 2 through 4 on high stage.
6. Turn ON gas to and relight all other appliances turned off in step 1. Be certain that all appliances are functioning properly and that all pilot burners are operating.

TEMPERATURE RISE

Temperature rise must be within the range specified on the unit rating plate. An incorrect temperature rise may result in condensing in or overheating of the heat exchanger. An airflow and temperature rise table is provided in the Specification Sheet applicable to your model. Determine and adjust temperature rise as follows:

1. Operate furnace with burners firing for approximately ten minutes. Ensure all registers are open and all duct dampers are in their final (fully or partially open) position.
2. Place thermometers in the return and supply ducts as close to the furnace as possible. Thermometers must not be influenced by radiant heat by being able to "see" the heat exchanger.
3. Subtract the return air temperature from the supply air temperature to determine the air temperature rise. Allow adequate time for thermometer readings to stabilize.
4. Adjust temperature rise by adjusting the circulator blower speed. Increase blower speed to reduce temperature rise. Decrease blower speed to increase temperature rise. Refer to *Startup Procedure and Adjustment - Circulator Blower Speeds* for speed changing details.

CROSS-HATCHED AREA SUBJECTED TO RADIANT HEAT. DO NOT MEASURE SUPPLY AIR TEMPERATURE IN THIS AREA.

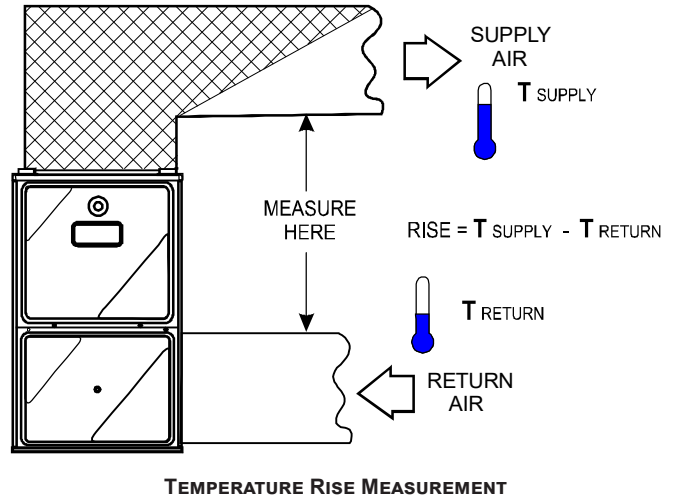

CIRCULATOR BLOWER SPEEDS

WARNING
TO AVOID PERSONAL INJURY OR DEATH DUE TO ELECTRICAL SHOCK, TURN OFF POWER TO THE FURNACE BEFORE CHANGING SPEED TAPS.

This furnace is equipped with a multi-speed circulator blower. This blower provides ease in adjusting blower speeds. The Specification Sheet applicable to your model provides an airflow table, showing the relationship between airflow (CFM) and external static pressure (E.S.P.), for the proper selection of heating and cooling speeds. The heating blower speed is shipped set at "B", and the cooling blower speed is set at "D". These blower speeds should be adjusted by the installer to match the installation requirements so as to provide the correct heating temperature rise and correct cooling CFM.

Use the dual 7-segment LED display adjacent to the dipswitches to obtain the approximate airflow quantity. The airflow quantity is displayed as a number on the display, rounded to the nearest 100 CFM. The display alternates airflow delivery indication and the operating mode indication.

Example: The airflow being delivered is 1225 CFM. The display indicates 12. If the airflow being delivered is 1275, the display indicates 13.

1. Determine the tonnage of the cooling system installed with the furnace. If the cooling capacity is in BTU/hr divide it by 12,000 to convert capacity to TONS.
Example: Cooling Capacity of 30,000 BTU/hr.
 30,000/12,000 = 2.5 Tons

- Determine the proper air flow for the cooling system. Most cooling systems are designed to work with air flows between 350 and 450 CFM per ton. Most manufacturers recommend an air flow of about 400 CFM per ton.

Example: 2.5 tons X 400 CFM per ton = 1000 CFM

The cooling system manufacturer's instructions must be checked for required air flow. Any electronic air cleaners or other devices may require specific air flows, consult installation instructions of those devices for requirements.

- Knowing the furnace model, locate the high stage cooling air flow charts in the Specification Sheet applicable to your model. Look up the cooling air flow determined in step 2 and find the required cooling speed and adjustment setting.

Example: A DM80VC0604BX furnace installed with a 2.5 ton air conditioning system. The air flow needed is 1000 CFM. Looking at the cooling speed chart for DM80VC0604BX, find the air flow closest to 1000 CFM. A cooling airflow of 990 CFM can be attained by setting the cooling speed to "C" and the adjustment to -10% trim.

- Continuous fan speeds that provide 25, 50, 75 and 100% of the furnace's maximum airflow capability are selectable via dip switches S5- 3, 4.

Example: If the furnace's maximum airflow capability is 2000 CFM and 25% continuous fan speed is selected, the continuous fan speed will be $0.25 \times 2000 \text{ CFM} = 500 \text{ CFM}$.

- Locate the blower speed selection DIP switches on the integrated control module. Select the desired "cooling" speed tap by positioning switches 1 and 2 appropriately. Select the desired "adjust" tap by positioning switches 3 and 4 appropriately. To enable adjustments and select -5, 5, -10 or 10% trim, you must set dipswitch S5-2 to ON. If S5-2 is in the OFF position, you will receive 0% trim. Refer to the following figure for switch positions and their corresponding taps. Verify CFM by noting the number displayed on the dual 7-segment LED display.
- The multi-speed circulator blower also offers several custom ON/OFF ramping profiles. These profiles may be used to enhance cooling performance and increase comfort level. The ramping profiles are selected using DIP switches S4- 1, 2. Refer to the following figure for switch positions and their corresponding taps. Refer to the bullet points below for a description of each ramping profile. Verify CFM by noting the number displayed on the dual 7-segment LED display.

Switch Bank: S4		
Ramping Profiles	DIP Switch No.	
	1	2
A*	OFF	OFF
B	ON	OFF
C	OFF	ON
D	ON	ON
(*Indicates factory setting)		

- Profile A** provides only an OFF delay of one (1) minute at 100% of the cooling demand airflow.

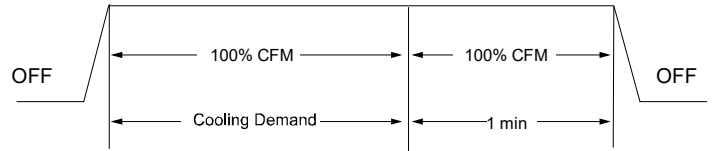

- Profile B** ramps up to full cooling demand airflow by first stepping up to 50% of the full demand for 30 seconds. The motor then ramps to 100% of the required airflow. A one (1) minute OFF delay at 100% of the cooling airflow is provided.

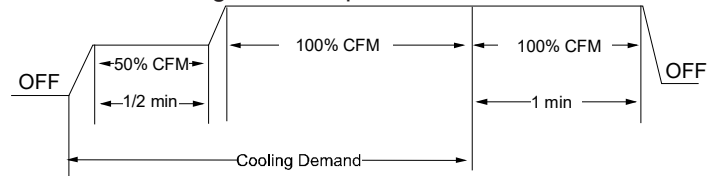

- Profile C** ramps up to 85% of the full cooling demand airflow and operates there for approximately 7 1/2 minutes. The motor then steps up to the full demand airflow. Profile C also has a one (1) minute 100% OFF delay.

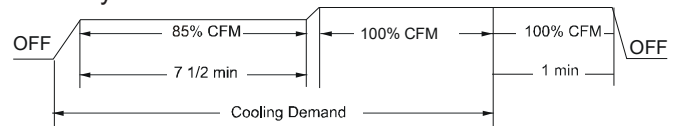

Switch Bank: S3		
Cooling Airflow	DIP Switch No.	
	1	2
A	OFF	OFF
B	ON	OFF
C	OFF	ON
D*	ON	ON
(*Indicates factory setting)		

Switch Bank: S3		
Adjust Taps	DIP Switch No.	
	3	4
+5%*	OFF	OFF
-5%	ON	OFF
10%	OFF	ON
-10%	ON	ON
(*Indicates factory setting)		

NOTE: TO ENABLE ADJUSTMENTS AND SELECT -5, 5, -10 OR 10% TRIM, YOU MUST SET DIP SWITCH S5-2 TO ON. IF S5-2 IS IN THE OFF POSITION, YOU WILL RECEIVE 0% TRIM.

- **Profile D** ramps up to 50% of the demand for ½ minute, then ramps to 85% of the full cooling demand airflow and operates there for approximately 7 ½ minutes. The motor then steps up to the full demand airflow. Profile D has a ½ minute at 50% airflow OFF delay.

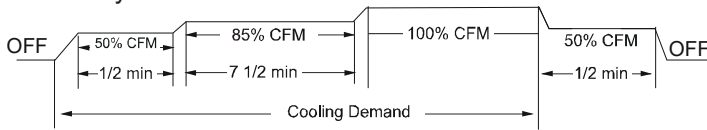

7. Select the heating speed for your model from the heating speed chart in the Specification Sheet. The adjust setting (already established by the cooling speed selection) determines which set of speeds are available. The selected speed must provide a temperature rise within the rise range listed with the particular model.

Example: If the DM80VC0604BX is set for 1210 CFM on cooling, the “ADJUST” is set to “+” (plus). The four heating speeds available are “A Plus”, “B Plus”, “C Plus”, and “D Plus”. “A Plus” has a rise of 38°F for both stages which is within the 20-50°F rise range for the DM80VC0604BX. This setting will keep electrical consumption to a minimum. Set the “Heat” speed DIP switches to “A”.

Switch Bank: S4		
Heating Airflow	DIP Switch No.	
	3	4
A	OFF	OFF
B*	ON	OFF
C	OFF	ON
D	ON	ON
(*Indicates factory setting)		

8. Select the desired “heating” speed tap by positioning switches S4- 3, 4 appropriately. Refer to figure above. Verify CFM by noting the number displayed on the dual 7-segment LED display.

In general lower heating speeds will: reduce electrical consumption, lower operating sound levels of the blower, and increase the outlet air temperature delivered to the home. The speeds available allow the blower performance to be optimized for the particular homeowner’s needs.

BLOWER HEAT OFF DELAY TIMINGS

The integrated control module provides a selectable heat off delay function. The heat off delay period may be set

to 90, 120, 150, 180 seconds using the DIP switches or jumper provided on the control module. The delay is factory shipped at 150 seconds but may be changed to suit the installation requirements and/or homeowner preference. Refer to the following figures for switch positions and corresponding delay times.

Switch Bank: S1		
Heat OFF Delay	DIP Switch No.	
	1	2
90 seconds	OFF	OFF
120 seconds	ON	OFF
150 seconds*	OFF	ON
180 seconds	ON	ON
(*Indicates factory setting)		

HEAT OFF DELAY DIP SWITCHES

DAIKIN COMMUNICATING SYSTEM

OVERVIEW

NOTE: WHEN INSTALLING A DAIKIN ONE+ SMART THERMOSTAT, PLEASE VISIT THE DAIKIN ONE+ SMART THERMOSTAT WEBSITE AT [HTTPS://WWW.DAIKINONE.COM](https://www.daikinone.com) FOR FULL INSTRUCTIONS ON A DETAILED PROCEDURE OF THERMOSTAT COMMISSIONING PROCESS.

NOTE: ONLY USE DAIKIN APPROVED COMMUNICATING THERMOSTATS. APPROVED COMMUNICATING THERMOSTATS ARE DAIKIN ONE+ SMART THERMOSTAT, AND CTK04.

The communicating system is a system that includes a communicating compatible furnace and air conditioner or heat pump with a communicating thermostat. A valid communicating system could also be a compatible furnace, communicating thermostat and non-compatible, single stage air conditioner. Any other system configurations are considered invalid communicating systems and must be connected as a traditional (or legacy) system (See *Electrical Connections* for wiring connections).

A communicating heating/air conditioning system differs from a non-communicating/traditional system in the manner in which the indoor unit, outdoor unit and thermostat interact with one another. In a traditional system, the thermostat sends commands to the indoor and outdoor units via analog 24 VAC signals. It is a one-way communication path in that the indoor and outdoor units typically do not return information to the thermostat. In a communicating system, the indoor unit, outdoor unit, and thermostat comprising a communicating system “communicate” digitally with one another creating a two-way communications path. The thermostat still sends commands to the indoor and outdoor units. However, the thermostat may also request and receive information from

both the indoor and outdoor units. This information may be displayed on the communicating thermostat. The indoor and outdoor units also interact with one another. The outdoor unit may send commands to or request information from the indoor unit. This two-way digital communications between the thermostat and subsystems (indoor/outdoor unit) and between subsystems is the key to unlocking the benefits and features of the communicating system.

Two-way digital communications is accomplished using only two wires. The thermostat and subsystem controls are powered with 24 VAC. Thus, a maximum of 4 wires between the equipment and thermostat is all that is required to operate the system.

AIRFLOW CONSIDERATIONS

Airflow demands are managed differently in a fully communicating system than they are in a non-communicating wired system. The system operating mode (as determined by the thermostat) determines which unit calculates the system airflow demand. If the indoor unit is responsible for determining the airflow demand, it calculates the demand and sends it to the ECM motor. If the outdoor unit or thermostat is responsible for determining the demand, it calculates the demand and transmits the demand along with a fan request to the indoor unit. The indoor unit then sends the demand to the ECM motor. The table below lists the various systems, the operating mode, and airflow demand source.

System	System Operating Mode	Airflow Demand Source
Air Conditioner + Furnace	Cooling	Air Conditioner
	Heating	Furnace
	Continuous Fan	Thermostat
Heat Pump + Furnace	Cooling	Heat Pump
	Heat Pump Heating Only	Heat Pump
	Auxiliary Heating	Furnace
	Continuous Fan	Thermostat
Furnace + Non-Comm 1stg Air Conditioner	Cooling	Furnace
	Heating	Furnace
	Continuous Fan	Thermostat

For example, assume the system is an air conditioner matched with a furnace. With a call for low stage cooling, the air conditioner will calculate the system's low stage cooling airflow demand. The air conditioner will then send a fan request along with the low stage cooling airflow demand to the furnace. Once received, the furnace will send the low stage cooling airflow demand to the ECM motor. The ECM motor then delivers the low stage cooling airflow. See the applicable communicating air conditioner or heat pump installation manual for the airflow delivered during cooling or heat pump heating.

In continuous fan mode, the thermostat provides the airflow demand. The thermostat may be configured for a low, medium, or high continuous fan speed. The low, medium, and high fan speeds correspond to 25%, 50%, and 75%, respectively, of the furnaces' maximum airflow capability. During continuous fan operation, the thermostat sends a fan request along with the continuous fan demand to the furnace. The furnace, in turn, sends the demand to the ECM motor. The ECM motor delivers the requested continuous fan airflow.

FOSSIL FUEL APPLICATIONS

This furnace can be used in conjunction with a communicating compatible heat pump in a fossil fuel application. A fossil fuel application refers to a combined gas furnace and heat pump installation which uses an outdoor temperature sensor to determine the most cost efficient means of heating (heat pump or gas furnace). The balance point temperature may be adjusted via the communicating thermostat advanced user menus (see communicating thermostat instructions for additional information).

DAIKIN COMMUNICATING THERMOSTAT WIRING

NOTE: A REMOVABLE PLUG CONNECTOR IS PROVIDED WITH THE CONTROL TO MAKE THERMOSTAT WIRE CONNECTIONS. THIS PLUG MAY BE REMOVED, WIRE CONNECTIONS MADE TO THE PLUG, AND REPLACED. IT IS STRONGLY RECOMMENDED THAT YOU DO NOT CONNECT MORE THAN TWO WIRES INTO A SINGLE TERMINAL IN THE FIELD BECAUSE THERE IS A RISK OF THE WIRES BECOMING LOOSE. FAILURE TO DO SO MAY RESULT IN INTERMITTENT OPERATION.

To wire the system components, it is strongly recommended to use the same type and the same gauge for the wires prepared in the field (for best results use 18 AWG).

TWO-WIRE OUTDOOR, FOUR-WIRE INDOOR WIRING

Typical Daikin communicating wiring will consist of two wires between the indoor and outdoor units, four wires between the indoor unit and the thermostat. The required wires are: (a) data lines, 1 and 2; (b) thermostat “R” (24 VAC hot) and “C” (24 VAC common).

IN CASE OF COIL WITHOUT ELECTRONIC EXPANSION VALVE (EEV)

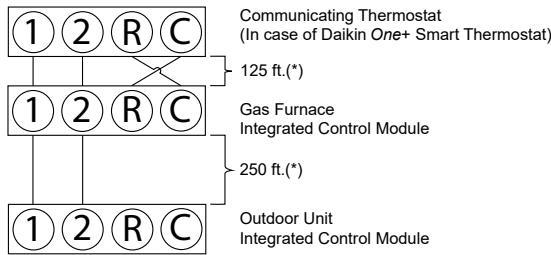

IN CASE OF COIL WITH ELECTRONIC EXPANSION VALVE (EEV)

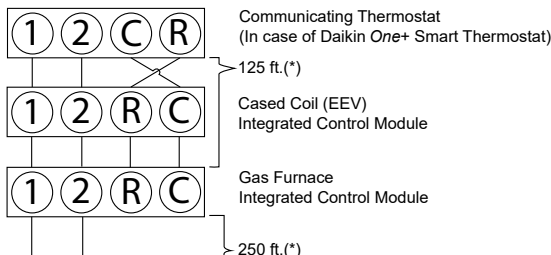

(*) Allowable Maximum Length

SYSTEM WIRING

DAIKIN COMMUNICATING COMPATIBLE FURNACE WITH NON-DAIKIN COMMUNICATING COMPATIBLE SINGLE-STAGE AIR CONDITIONER

Four wires are required between the furnace and thermostat. Two wires are required between the furnace control and single stage air conditioner. For this system configuration, the “Y1” terminal on the integrated furnace control becomes an output rather than an input.

NOTE: AN 11 POSITION LOW VOLTAGE CONNECTOR IS SUPPLIED WITH RECENT PRODUCTION FURNACES. THIS CONNECTOR FACILITATES CONNECTION TO BOTH COMMUNICATING & NON-COMMUNICATING THERMOSTATS TYPES (SEE 11-POSITION CONNECTOR IMAGE FOR DETAILS).

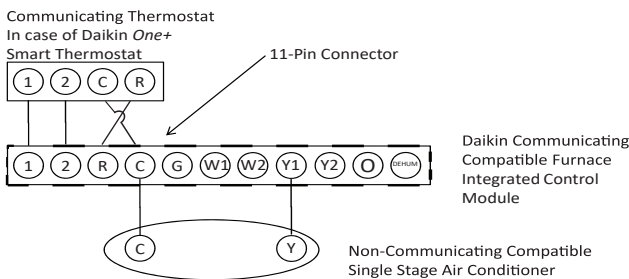

SYSTEM WIRING BETWEEN FURNACE AND NON-COMMUNICATING COMPATIBLE SINGLE STAGE AIR CONDITIONER

NOTE: WHEN USING A NON-COMMUNICATING CONDENSER, COOLING CFM WILL NEED TO BE SET UP IN THE COMMUNICATING THERMOSTAT AND SELECT THE CONDENSER SIZE FROM THE LIST 18,000 - 60,000 FOR PROPER COOLING CFM.

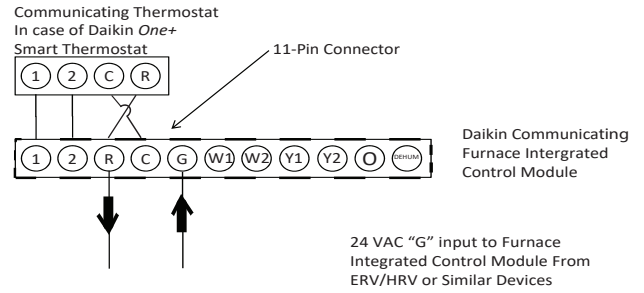

NOTE: PCBKF108 IFC HAS THE ADDED FEATURE OF 24 VAC INPUT TO G TERMINAL WHEN USING A COMMUNICATING THERMOSTAT. ERV/HRV AND OTHER ACCESSORIES CAN SEND A SIGNAL TO THE G TERMINAL AND ENERGIZE THE CONTINUOUS FAN. THE CONTINUOUS FAN SPEED CAN BE ADJUSTED ON SWITCH BANK S5, DIP SWITCH 3 & 4. THE 24 VAC SOURCE MUST ORIGINATE FROM THE R TERMINAL OF FURNACE.

DAIKIN COMMUNICATING SYSTEM ADVANCED FEATURES

The communicating system permits access to additional system information, advanced setup features, and advanced diagnostic / troubleshooting features. These advanced features are organized into a menu structure. The menus are accessed and navigated by means of the communicating thermostat. For details, see the thermostat instruction sheet.

THERMOSTAT MENU

If this furnace is installed with a communicating compatible heat pump, the system is recognized as a dual fuel system. The balance point temperature should be set via the thermostat advanced menu.

DIAGNOSTICS		
Submenu Item	Indication/User Modifiable Options	Comments
Fault 1 (FAULT #1)	Most recent furnace fault	For display only
Fault 2 (FAULT #2)	Next most recent furnace fault	For display only
Fault 3 (FAULT #3)	Next most recent furnace fault	For display only
Fault 4 (FAULT #4)	Next most recent furnace fault	For display only
Fault 5 (FAULT #5)	Next most recent furnace fault	For display only
Fault 6 (FAULT #6)	Least recent furnace fault	For display only
Clear Fault History (CLEAR)	NO or YES	Selecting "YES" clears the fault history

NOTE: Consecutively repeated faults are shown a maximum of 3 times

IDENTIFICATION	
Submenu Item	Indication (for Display Only; not User Modifiable)
Model Number (MOD NUM)	Displays the furnace model number
Serial Number (SER NUM)	Displays the furnace serial number (Optional)
Software (SOFTWARE)	Displays the application software revision

SET-UP		
Submenu Item	User Modifiable Options	Comments
Heat Airflow Trim (HT TRM)	-10% to +10% in 2% increments, default is 0%	Trims the heating airflow by the selected amount.
Heat ON Delay (HT ON)	5, 10, 15, 20, 25, or 30 seconds, default is 30 seconds	Selects the indoor blower heat ON delay
Heat OFF Delay (HT OFF)	30, 60, 90, 120, 150, or 180 seconds, default is 150 seconds	Selects the indoor blower heat OFF delay
Heat Airflow (HT ADJ)	1, 2, 3, or 4	Selects the nominal heating airflow (see <i>Startup Procedure and Adjustment – Circulator Blower Speeds</i> for addition information)
Auxiliary Alarm	ON / OFF	Enable or Disable Auxiliary Alarm Input
Humidity Setting	ON / OFF / IND	Select Humidity Relay Functionality. ON - Humidifier is turned on with heat demand. OFF - Humidifier remains off. IND - Humidifier will cycle with humidification demand (independent of an active heat demand)
Humidity Fan Speed	1, 2, 3, 4	Select Humidity Fan Speed (this option is enabled when Humidity Setting of IND is selected). 1 - 25%, 2 - 50%, 3 - 75%, 4 - 100% of maximum airflow.

NON-COMM (APPLIES ONLY TO A COMMUNICATING COMPATIBLE FURNACE MATCHED WITH A NON-COMMUNICATING COMPATIBLE SINGLE STAGE AIR CONDITIONER)		
Submenu Item	User Modifiable Options	Comments
Cool Airflow (CL CFM)	18, 24, 30, 36, 42, 48, or 60, default is 18	Selects the airflow for the non-communicating compatible single stage AC unit
Cool Airflow Trim (CL TRM)	-10% to +10% in 2% increments, default is 0%	Selects the airflow trim amount for the non-communicating compatible single stage AC unit
Cool Airflow Profile (CL PRFL)	A, B, C, or D, default is A	Selects the airflow profile for the non-communicating compatible single stage AC unit
Cool ON Delay (CL ON)	5, 10, 20, or 30 seconds, default is 5 seconds	Selects the indoor blower ON delay for the non-communicating compatible single stage AC unit
Cool OFF Delay (CL OFF)	30, 60, 90, or 120 seconds, default is 30 seconds	Selects the indoor blower OFF delay for the non-communicating compatible single stage AC unit

DIAGNOSTICS

Accessing the furnace's diagnostics menu provides ready access to the last six faults detected by the furnace. Faults are stored most recent to least recent. Any consecutively repeated fault is stored a maximum of three times.

EXAMPLE: A clogged return air filter causes the furnace limit to trip repeatedly. The control will only store this fault the first three *consecutive* times the fault occurs. Navigate to the diagnostics menu as described in the thermostat installer manual.

NOTE: IT IS HIGHLY RECOMMENDED THAT THE FAULT HISTORY BE CLEARED WHEN PERFORMING MAINTENANCE OR SERVICING THE FURNACE.

NETWORK TROUBLESHOOTING

The integrated furnace control has some on-board tools that may be used to troubleshoot the network. These tools are: red communications LED, green receive (Rx) LED, and learn button.

- Red communications LED – Indicates the status of the network. The table below indicates the LED status and the corresponding potential problem.
- Green receive LED – Indicates network traffic. The table below indicates the LED status and the corresponding potential problem.
- Learn button – Used to reset the network. Depress the button for approximately 2 seconds to reset the network.

SYSTEM TROUBLESHOOTING

NOTE: REFER TO THE INSTRUCTIONS ACCOMPANYING THE COMMUNICATING COMPATIBLE OUTDOOR AC/HP UNIT FOR TROUBLESHOOTING INFORMATION.

Refer to the Troubleshooting Chart in the back of this manual for a listing of possible furnace error codes, possible causes and corrective actions.

NORMAL SEQUENCE OF OPERATION

POWER UP

The normal power up sequence is as follows:

- 115 VAC power applied to furnace.
- Integrated control module performs internal checks.
- Integrated control module displays $\bar{B} \bar{B}$ on dual 7-segment display LED's.
- Integrated control module monitors safety circuits continuously.
- Furnace awaits call from thermostat. Dual 7-segment LED's display $\bar{0} \bar{n}$ while awaiting call from thermostat.

	LED	Description	Possible Cause	Corrective Action	Comments
	Off	Normal condition	None	None	None
Red Communications LED	1 Flash	Communications Failure	Communications Failure	<ul style="list-style-type: none"> •Depress Learn Button •Verify that bus BIAS and TERM dipswitches are in the ON position. 	<ul style="list-style-type: none"> •Depress once quickly for a power-up reset •Depress and hold for 2 seconds for an out-of-box reset
	2 Flashes	Out-of-box reset	<ul style="list-style-type: none"> •Control power up •Learn button depressed 	None	None
Green Receive LED	Off	<ul style="list-style-type: none"> •Nopower •Communications error 	<ul style="list-style-type: none"> •No power to furnace •Open fuse •Communications error 	<ul style="list-style-type: none"> •Check fuses and circuit breakers; replace/reset •Replace blown fuse •Check for shorts in low voltage wiring in furnace/ system •Reset network by depressing learn button •Check data 1/ data 2 voltages 	<ul style="list-style-type: none"> •Turn power OFF prior to repair
	1 Steady Flash	No network found	<ul style="list-style-type: none"> •Broken/ disconnected data wire(s) •Furnace is installed as a legacy/ traditional system 	<ul style="list-style-type: none"> •Check communications wiring (data 1/ data 2 wires) •Check wire connections at terminal block •Verify furnace installation type (legacy/ traditional or communicating) Check data 1/ data 2 voltages 	<ul style="list-style-type: none"> •Turn power OFF prior to repair •Verify wires at terminal blocks are securely twisted together prior to inserting into terminal block •Verify data1 and data voltages as described above
	Rapid Flashing	Normal network traffic	Control is "talking" on network as expected	None	None
	On Solid	Data 1/ Data 2 miss-wire	<ul style="list-style-type: none"> •Data 1 and data 2 wires reversed at furnace, thermostat, or CT™ compatible outdoor AC/ HP •Short between data 1 and data 2 wires •Short between data 1 or data 2 wires and R (24VAC) or C (24VAC common) 	<ul style="list-style-type: none"> •Check communications wiring (data 1/ data 2 wires) •Check wire connections at terminal block •Check data 1/ data 2 voltages 	<ul style="list-style-type: none"> •Turn power OFF prior to repair •Verify wires at terminal blocks are securely twisted together prior to inserting into terminal block •Verify data1 and data voltages as described above

HEATING MODE

The normal operational sequence in heating mode is as follows:

- R and W1 (or R and W1 / W2) thermostat contacts close, initiating a call for heat.
- Integrated control module performs safety circuit checks.
- Induced draft blower is energized on high speed for a 15-second prepurge. Humidifier terminal is energized with induced draft blower.
- Induced draft blower steps to low speed following prepurge. Low stage pressure switch contacts are closed.
- Igniter warm up begins upon step to low speed and presence of closed low stage pressure switch contacts.
- Gas valve opens at end of igniter warm up period, delivering gas to burners and establishing flame.
- Integrated control module monitors flame presence. Gas valve will remain open only if flame is detected.
- If the thermostat call is for low heat, gas valve and induced draft blower will continue on low stage. If the call is for high heat, the gas valve and induced draft blower will change to high stage.
- Circulator blower is energized on heat speed following a thirty (30) second blower on delay. The circulator blower requires thirty seconds to ramp up to full speed. Electronic air cleaner terminal is energized with circulator blower.
- Furnace is now operating on the specified stage called for by the two-stage thermostat.
- Furnace runs, integrated control module monitors safety circuits continuously.
- If the two-stage thermostat changes the call from low heat to high heat, the integrated control module will immediately switch the induced draft blower, gas valve, and circulator blower to their high stage settings.

- If the two-stage thermostat changes the call from high heat to low heat, the control will immediately switch the induced draft blower and gas valve to their low stage settings. The circulator blower will remain on high heating speed for thirty (30) seconds before switching to the low heat circulating speed.
- R and W1 (or R and W1/W2) thermostat contacts open, completing the call for heat.
- Gas valve closes, extinguishing flame.
- Induced draft blower is de-energized following a fifteen second post purge. Humidifier terminals are de-energized.
- Circulator blower continues running for the selected heat off delay period (90, 120, 150 or 180 seconds). The speed run during this period depends on the last heat call provided by the thermostat.
If the last call for heat was a call for low heat, the air circulator motor will run on low heat speed for the duration of the heat off delay period (90, 120, 150 or 180 seconds).
If the last call for heat was a call for high heat, the air circulating motor will run on the high heating speed for thirty (30) seconds and then switch to the low heating speed for the **balance** of the heat off delay period (60, 90, 120 or 150 seconds).
- Circulator blower and electronic air cleaner terminal is de-energized.
- Circulator blower ramps down to OFF during the 30 seconds following the heat off delay period.
- Furnace awaits next call from thermostat.

COOLING MODE

The normal operational sequence in cooling mode is as follows:

- R and Y1/G or Y2/G thermostat contacts close, initiating a call for cool.
- Integrated control module performs safety circuit checks.
- Outdoor fan and compressor are energized to their appropriate speed.
- Circulator blower is energized on the appropriate cool speed at the level and time determined by the selected ramping profile. Electronic air cleaner terminal is energized with circulator blower.
- Furnace circulator blower and outdoor cooling unit run their appropriate speeds, integrated control module monitors safety circuits continuously.
- R and Y1/G or Y2/G thermostat contacts open, completing the call for cool.
- Outdoor fan and compressor are de-energized.
- Circulator blower continues running during a cool off delay period. The OFF delay time and airflow level are determined by the selected ramping profile.
- Electronic air cleaner terminal and circulator blower are de-energized.
- Furnace awaits next call from thermostat.

FAN ONLY MODE

The normal operational sequence in fan only mode is as follows:

- R and G thermostat contacts close, initiating a call for fan.
- Integrated control module performs safety circuit checks.
- Circulator blower is energized on continuous fan speed (25, 50, 75 or 100% of the furnace's maximum airflow capability. Fan speed selected by dip switches.) following a five (5) second delay. Electronic air cleaner terminal is energized.
- Circulator blower runs, integrated control module monitors safety circuits continuously.
- R and G thermostat contacts open, completing the call for fan.
- Circulator blower is de-energized. Electronic air cleaner terminal is de-energized.
- Furnace awaits next call from thermostat.

OPERATIONAL CHECKS

The burner flames should be inspected with the burner compartment door installed. Flames should be stable, quiet, soft, and blue (dust may cause orange tips but they must not be yellow). Flames should extend directly outward from the burners without curling, floating, or lifting off. Flames must not impinge on the sides of the heat exchanger firing tubes.

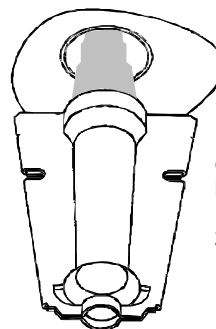

Check the Burner Flames for:
1. Stable, soft and blue.
2. Not curling, floating or lifting off.

BURNER FLAME

SAFETY CIRCUIT DESCRIPTION

 WARNING
DO NOT BYPASS SAFETY DEVICES.

A number of safety circuits are employed to ensure safe and proper furnace operation. These circuits serve to control any potential safety hazards and serve as inputs in the monitoring and diagnosis of abnormal function. These circuits are continuously monitored during furnace operation by the integrated control module.

INTEGRATED CONTROL MODULE

The integrated control module is an electronic device which, if a potential safety concern is detected, will take the necessary precautions and provide diagnostic information through an LED.

PRIMARY LIMIT

The primary limit control is located on the partition panel and monitors heat exchanger compartment temperatures. It is a normally-closed (electrically), automatic reset, temperature-activated sensor. The limit guards against overheating as a result of insufficient conditioned air passing over the heat exchanger.

AUXILIARY LIMIT

The auxiliary limit controls are located on or near the circulator blower and monitors blower compartment temperatures. They are a normally-closed (electrically), auto-reset sensors. These limits guard against overheating as a result of insufficient conditioned air passing over the heat exchanger.

ROLLOUT LIMIT

The rollout limit controls are mounted on the burner/manifold assembly and monitor the burner flame. They are normally-closed (electrically), manual-reset sensors. These limits guard against burner flames not being properly drawn into the heat exchanger.

PRESSURE SWITCHES

The pressure switches are normally-open (closed during operation) negative air pressure-activated switches. They monitor the airflow (combustion air and flue products) through the heat exchanger via pressure taps located on the induced draft blower and the coil front cover. These switches guard against insufficient airflow (combustion air and flue products) through the heat exchanger and/or blocked condensate drain conditions.

FLAME SENSOR

The flame sensor is a probe mounted to the burner/manifold assembly which uses the principle of flame rectification to determine the presence or absence of flame.

TROUBLESHOOTING

ELECTROSTATIC DISCHARGE (ESD) PRECAUTIONS

NOTE: DISCHARGE BODY'S STATIC ELECTRICITY BEFORE TOUCHING UNIT. AN ELECTROSTATIC DISCHARGE CAN ADVERSELY AFFECT ELECTRICAL COMPONENTS.

Use the following precautions during furnace installation and servicing to protect the integrated control module from damage. By putting the furnace, the control, and the person at the same electrostatic potential, these steps will help avoid exposing the integrated control module to electrostatic discharge. This procedure is applicable to both installed and uninstalled (ungrounded) furnaces.

1. Disconnect all power to the furnace. Do not touch the integrated control module or any wire connected to the control prior to discharging your body's electrostatic charge to ground.
2. Firmly touch a clean, unpainted, metal surface of the furnace away from the control. Any tools held in a person's hand during grounding will be discharged.
3. Service integrated control module or connecting wiring following the discharge process in step 2. Use caution not to recharge your body with static electricity; (i.e., do not move or shuffle your feet, do not touch ungrounded objects, etc.). If you come in contact with an ungrounded object, repeat step 2 before touching control or wires.
4. Discharge your body to ground before removing a new control from its container. Follow steps 1 through 3 if installing the control on a furnace. Return any old or new controls to their containers before touching any ungrounded object.

DIAGNOSTIC CHART

 WARNING	
HIGH VOLTAGE TO AVOID PERSONAL INJURY OR DEATH DUE TO ELECTRICAL SHOCK, DISCONNECT ELECTRICAL POWER BEFORE PERFORMING ANY SERVICER OR MAINTENANCE.	

Refer to the *Troubleshooting Chart* at the end of this manual for assistance in determining the source of unit operational problems. The dual 7-segment LED display will display an error code that may contain a letter and number. The error code may be used to assist in troubleshooting the unit.

FAULT RECALL

The ignition control is equipped with a momentary push-button switch that can be used to display the last six faults on the dual 7-segment LED's. The control must be in Standby Mode (no thermostat inputs) to use the feature. Depress the switch for approximately 2 seconds. Release the switch when the LED's are turned off. The last six faults will be displayed most recent to least recent on the dual 7-segment LED's.

NOTE: CONSECUTIVELY REPEATED FAULTS ARE STORED A MAXIMUM OF THREE TIMES. EXAMPLE: A CLOGGED RETURN AIR FILTER CAUSES THE FURNACE LIMIT TO TRIP REPEATEDLY. THE CONTROL WILL ONLY STORE THIS FAULT THE FIRST THREE CONSECUTIVE TIMES THE FAULT OCCURS.

FAULT CLEAR SEQUENCE:

- Only allowed in standby mode, while display is showing ON.
- Hold fault recall push-button for 5-10 seconds (until display starts flashing "---") and then release.

- All faults in the history will have been cleared, and display returns to ON.
- If the button is held for longer than 10 seconds, the display will return to ON and the faults will not be cleared.



RESETTING FROM LOCKOUT

Furnace lockout results when a furnace is unable to achieve ignition after three attempts during a single call for heat. It is characterized by a non-functioning furnace and a E □ code displayed on the dual 7-segment display. If the furnace is in “lockout”, it will (or can be) reset in any of the following ways.

1. Automatic reset. The integrated control module will automatically reset itself and attempt to resume normal operations following a one hour lockout period.
2. Manual power interruption. Interrupt 115 volt power to the furnace.
3. Manual thermostat cycle. Lower the thermostat so that there is no longer a call for heat for 1 - 20 seconds then reset to previous setting.

NOTE: IF THE CONDITION WHICH ORIGINALLY CAUSED THE LOCKOUT STILL EXISTS, THE CONTROL WILL RETURN TO LOCKOUT. REFER TO THE *DIAGNOSTIC CHART* FOR AID IN DETERMINING THE CAUSE.

MAINTENANCE

 WARNING	
<p>TO AVOID ELECTRICAL SHOCK, INJURY OR DEATH, DISCONNECT ELECTRICAL POWER BEFORE PERFORMING ANY MAINTENANCE. IF YOU MUST HANDLE THE IGNITER, HANDLE WITH CARE. TOUCHING THE IGNITER ELEMENT WITH BARE FINGERS, ROUGH HANDLING OR VIBRATION COULD DAMAGE THE IGNITER RESULTING IN PREMATURE FAILURE. ONLY A QUALIFIED SERVICER SHOULD EVER HANDLE THE IGNITER.</p>	

ANNUAL INSPECTION

The furnace should be inspected by a qualified installer, or service agency at least once per year. This check should be performed at the beginning of the heating season. This will ensure that all furnace components are in proper working order and that the heating system functions appropriately. Pay particular attention to the following items. Repair or service as necessary.

- Flue pipe system. Check for blockage and/or leakage. Check the outside termination and the connections at and internal to the furnace.

- Heat exchanger. Check for corrosion and/or buildup within the heat exchanger passageways.
- Burners. Check for proper ignition, burner flame, and flame signal.
- Drainage system. Check for blockage and/or leakage. Check hose connections at and internal to furnace.
- Wiring. Check electrical connections for tightness and/or corrosion. Check wires for damage.
- Filters.

FILTERS

 CAUTION
<p>TO ENSURE PROPER UNIT PERFORMANCE, ADHERE TO THE FILTER SIZES GIVEN IN THE RECOMMENDED MINIMUM FILTER SIZE TABLE OR SPECIFICATION SHEET APPLICABLE TO YOUR MODEL.</p>

FILTER MAINTENANCE

Improper filter maintenance is the most common cause of inadequate heating or cooling performance. Filters should be cleaned (permanent) or replaced (disposable) as required.

FILTER REMOVAL

Depending on the installation, differing filter arrangements can be applied. Filters can be installed in either the central return register or a side panel external filter rack (upflow only). A media air filter or electronic air cleaner can be used as an alternate filter. Follow the filter sizes given in the Recommended Minimum Filter size table to ensure proper unit performance.

To remove filters from an external filter rack in an upright upflow installation, follow the directions provided with external filter rack kit.

HORIZONTAL UNIT FILTER REMOVAL

Filters in horizontal installations are located in the central return register or the ductwork near the furnace.

To remove:

1. Turn OFF electrical power to furnace.
2. Remove filter(s) from the central return register or ductwork.
3. Replace filter(s) by reversing the procedure for removal.
4. Turn ON electrical power to furnace.

**MEDIA AIR FILTER OR ELECTRONIC
AIR CLEANER REMOVAL**

Follow the manufacturer's directions for service.

BURNERS

Visually inspect the burner flames periodically during the heating season. Turn on the furnace at the thermostat and allow several minutes for flames to stabilize, since any dislodged dust will alter the flames normal appearance. Flames should be stable, quiet, soft, and blue (dust may cause orange tips but they must not be yellow). They should extend directly outward from the burners without curling, floating, or lifting off. Flames must not impinge on the sides of the heat exchanger firing tubes.

INDUCED DRAFT AND CIRCULATOR BLOWERS

The bearings in the induced draft blower and circulator blower motors are permanently lubricated by the manufacturer. No further lubrication is required. Check motor windings for accumulation of dust which may cause overheating. Clean as necessary.

FLAME SENSOR (QUALIFIED SERVICER ONLY)

Under some conditions, the fuel or air supply can create a nearly invisible coating on the flame sensor. This coating acts as an insulator causing a drop in the flame sense signal. If the flame sense signal drops too low the furnace will not sense flame and will lock out. The flame sensor should be carefully cleaned by a qualified servicer using emery cloth or steel wool. Following cleaning, the flame sense signal should be as indicated in the Specifications Sheet.

FLUE PASSAGES (QUALIFIED SERVICER ONLY)

The heat exchanger flue passageways should be inspected at the beginning of each heating season.

BEFORE LEAVING AN INSTALLATION

- Cycle the furnace with the thermostat at least three times. Verify cooling and fan only operation.
- Review the Owner's Manual with the homeowner and discuss proper furnace operation and maintenance.
- Leave literature packet near furnace.

REPAIR AND REPLACEMENT PARTS

- When ordering any of the listed functional parts, be sure to provide the furnace model, manufacturing, and serial numbers with the order.
- Although only functional parts are shown in the parts list, all sheet metal parts, doors, etc. may be ordered by description.
- Parts are available from your distributor.

FUNCTIONAL PARTS LIST-

- | | |
|----------------------|---------------------------|
| Gas Valve | Blower Motor |
| Gas Manifold | Blower Wheel |
| Natural Gas Orifice | Blower Mounting Bracket |
| Propane Gas Orifice | Blower Cutoff |
| Igniter | Blower Housing |
| Flame Sensor | Inductor |
| Rollout Limit Switch | Heat Exchanger |
| Primary Limit Switch | Auxiliary Limit Switch |
| Pressure Switch | Integrated Control Module |
| Induced Draft Blower | Transformer |
| Door Switch | |

TROUBLESHOOTING CHART

If you are attempting to install a Daikin *One+* Communicating Thermostat, please visit the Daikin *One+* Smart Thermostat website at <http://www.daikinone.com> for detailed information on the unitary error codes.

If installing with a CTK04 thermostat, please continue reading for further instructions.

Symptoms of Abnormal Operation (Legacy & ComfortNet™ Thermostat)	Diagnostic/ Status LED Codes	Fault Description	ComfortNet™ Thermostat Only		Possible Causes	Corrective Actions	Notes & Cautions
			Message	Code			
<ul style="list-style-type: none"> Furnace fails to operate Integrated control module LED display provides no signal. ComfortNet™ thermostat "Call for Service" icon illuminated ComfortNet™ thermostat scrolls "Check Furnace" message 	None	<ul style="list-style-type: none"> No 115 power to furnace or no 24 volt power to integrated control module Blown fuse or circuit breaker Integrated control module has an internal fault 	INTERNAL FAULT	EE	<ul style="list-style-type: none"> Manual disconnect switch OFF, door switch open or 24 volt wire improperly connected or loose Blown fuse or circuit breaker Integrated control module has an internal fault 	<ul style="list-style-type: none"> Assure 115 and 24 volt power to furnace and integrated control module. Check integrated control module fuse (3A). Replace if necessary. Check for possible shorts in 115 and 24 volt circuits. Repair as necessary. Replace bad integrated control module. 	<ul style="list-style-type: none"> Turn power OFF prior to repair. Replace integrated control module fuse with 3A automotive fuse. Read precautions in "Electrostatic Discharge" section of manual. Replace control with correct replacement part
<ul style="list-style-type: none"> LED display indicates On 	On	<ul style="list-style-type: none"> Normal operation 	None	None	<ul style="list-style-type: none"> Normal operation 	<ul style="list-style-type: none"> None 	<ul style="list-style-type: none"> Normal operation
<ul style="list-style-type: none"> Furnace fails to operate Integrated control module LED display provides E0 error code. ComfortNet™ thermostat "Call for Service" icon illuminated. ComfortNet™ thermostat scrolls "Check Furnace" message. 	E0	<ul style="list-style-type: none"> Furnace lockout due to an excessive number of ignition "retries" (3 total) 	LOCKOUT	E0	<ul style="list-style-type: none"> Failure to establish flame. Cause may be no gas to burners, bad igniter or igniter alignment, improper Orifices, or coated/oxidized or improperly connected flame sensor. Loss of flame after establishment. Cause may be interrupted gas supply, lazy burner flames (improper gas pressure or restriction in fuel or improper induced draft blower performance. 	<ul style="list-style-type: none"> Locate and correct gas interruption. Replace or realign igniter. Check flame sense signal. Clean sensor if coated and/or oxidized. Check flue piping for blockage, proper length, elbows, and termination. Verify proper induced draft blower performance. 	<ul style="list-style-type: none"> Turn power OFF prior to repair. Igniter is fragile, handle with care. Clean flame sensor with emery cloth. See "Vent/Flue Pipe" section for piping details.
<ul style="list-style-type: none"> Furnace fails to operate. Integrated control module LED display provides E1 error code. ComfortNet™ thermostat "Call for Service" icon illuminated. ComfortNet™ thermostat scrolls "Check Furnace" message. 	E1	<ul style="list-style-type: none"> Low stage pressure switch circuit is closed at start of heating cycle. 	PS1 CLOSED	E1	<ul style="list-style-type: none"> Low stage pressure switch contacts sticking. Shorts in pressure switch circuit wiring. 	<ul style="list-style-type: none"> Replace low stage pressure switch. Repair short in wiring. 	<ul style="list-style-type: none"> Turn power OFF prior to repair. Replace pressure switch with proper replacement part.

TROUBLESHOOTING CHART

Symptoms of Abnormal Operation (Legacy & ComfortNet™ Thermostat)	Diagnostic / Status LED Codes	Fault Description	ComfortNet™ Thermostat Only		Possible Causes	Corrective Actions	Notes & Cautions
			Message	Code			
<ul style="list-style-type: none"> Induced draft blower runs continuously with no further furnace operation. Integrated control module LED display provides E2 error code. ComfortNet™ thermostat "Call for Service" icon illuminated. ComfortNet™ thermostat scrolls "Check Furnace" message. 	E2	<ul style="list-style-type: none"> Low stage pressure switch circuit is not closed. 	PS1 OPEN	E2	<ul style="list-style-type: none"> Pressure switch hose blocked pinched, or connected improperly. Blocked flue or weak induced draft blower. Incorrect pressure switch set point or malfunctioning switch contacts. Loose or improperly connected wiring. 	<ul style="list-style-type: none"> Inspect pressure switch hose. Repair/replace if necessary. Inspect flue for blockage, proper length, elbows, and termination. Correct as necessary. Check induced draft blower performance. Correct as necessary. Correct pressure switch set point or contact motion. Tighten or correct wiring connection. 	<ul style="list-style-type: none"> Turn power OFF prior to repair. Replace pressure switch with proper replacement part. Replace induced draft blower with proper replacement part.
<ul style="list-style-type: none"> Circulator blower runs continuously. No furnace operation. Integrated control module LED display provides E3 error code. ComfortNet™ thermostat "Call for Service" icon illuminated. ComfortNet™ thermostat scrolls "Check Furnace" message. 	E3	<ul style="list-style-type: none"> Primary limit or auxiliary limit circuit is open. Rollout limit circuit is open. 	HIGH LIMIT OPEN	E3	<ul style="list-style-type: none"> Insufficient conditioned air over the heat exchanger. Blocked Filters, restrictive ductwork, improper circulator blower speed, or failed circulator blower motor. Flame rollout. Misaligned burners, blocked flue pipe, or failed induced draft blower. Loose or improperly connected wiring. 	<ul style="list-style-type: none"> Check filters and ductwork for blockage. Clean filters or remove obstruction. Check circulator blower speed and performance. Correct speed or replace blower motor if necessary. Check burners for proper alignment. Check flue piping for blockage, proper length, elbows, and termination. Correct as necessary. Check induced draft blower for proper performance. Replace if necessary. Tighten or correct wiring connection. 	<ul style="list-style-type: none"> Turn power OFF prior to repair. See Specification Sheet applicable to your model* for allowable rise range and proper circulator speed. See "Vent/Flue Pipe" section for piping details.
<ul style="list-style-type: none"> Induced draft blower and circulator blower runs continuously. No furnace operation. Integrated control module LED display provides E4 error code. ComfortNet™ thermostat "Call for Service" icon illuminated. ComfortNet™ thermostat scrolls "Check Furnace" message. 	E4	<ul style="list-style-type: none"> Flame sensed with no call for heat. 	IMPROPER FLAME	E4	<ul style="list-style-type: none"> Short to ground in Flame sense circuit. Lingering burner fame. Slow closing gas valve. 	<ul style="list-style-type: none"> Correct short at flame sensor or in flame sensor wiring. Check for lingering Flame. Verify proper operation of gas valve. 	<ul style="list-style-type: none"> Turn power OFF prior to repair.
<ul style="list-style-type: none"> No furnace operation. Integrated control module LED display provides E5 error code. ComfortNet™ thermostat displays "Battery Power" 	E5	<ul style="list-style-type: none"> Open Fuse 	Not Displayed	Not Displayed	<ul style="list-style-type: none"> Short in low voltage wiring. 	<ul style="list-style-type: none"> Locate and correct short in low voltage wiring. 	<ul style="list-style-type: none"> Turn power OFF prior to repair. Replace fuse with 3-amp automotive type.
<ul style="list-style-type: none"> Normal furnace operation. Integrated control module LED display provides E6 error code. 	E6	<ul style="list-style-type: none"> Flame sense micro amp signal is low 	WEAK FLAME	E6	<ul style="list-style-type: none"> Flame sensor is coated/oxidized. Flame sensor incorrectly positioned in burner fame. Lazy burner flame due to improper gas pressure or combustion air. 	<ul style="list-style-type: none"> Clean flame sensor if coated/oxidized. Inspect for proper sensor alignment. Compare current gas pressure to rating plate. Adjust as needed. 	<ul style="list-style-type: none"> Turn power OFF prior to repair. Clean flame sensor with emery cloth. See "Vent/Flue Pipe" section for piping details. See rating plate for proper gas pressure.

TROUBLESHOOTING CHART

Symptoms of Abnormal Operation (Legacy & ComfortNet™ Thermostat)	Diagnostic/ Status LED Codes	Fault Description	ComfortNet™ Thermostat Only		Possible Causes	Corrective Actions	Notes & Cautions
			Message	Code			
<ul style="list-style-type: none"> Furnace fails to operate. Integrated control module LED display provides E7 error code. ComfortNet™ thermostat "Call for Service" icon illuminated. ComfortNet™ thermostat scrolls "Check Furnace" message. 	E7	<ul style="list-style-type: none"> Problem with igniter circuit. 	IGNITER FAULT	E7	<ul style="list-style-type: none"> Improperly connected igniter. Shorted igniter. Poor unit ground. Igniter relay fault on integrated control module. 	<ul style="list-style-type: none"> Check and correct wiring from integrated control module to igniter. Replace shorted igniter. Check and correct unit ground wiring. Check igniter output from control. Replace if necessary. 	<ul style="list-style-type: none"> Turn power OFF prior to repair. Replace igniter with correct replacement part. Replace control with correct replacement part.
<ul style="list-style-type: none"> Furnace fails to operate on high stage; furnace operates normally on low stage. Integrated control module LED display provides E8 error code. 	E8	<ul style="list-style-type: none"> High stage pressure switch circuit is closed at start of heating cycle. Induced draft blower is operating. Furnace is operating on low stage only. 	PS2 CLOSED	E8	<ul style="list-style-type: none"> High stage pressure switch contacts sticking. Shorts in pressure switch circuit wiring. 	<ul style="list-style-type: none"> Replace high stage pressure switch. Repair short in wiring 	<ul style="list-style-type: none"> Turn power OFF prior to repair. Replace pressure switch with proper replacement part.
<ul style="list-style-type: none"> Furnace fails to operate on high stage; furnace operates normally on low stage. Integrated control module LED display provides E9 error code. 	E9	<ul style="list-style-type: none"> High stage pressure switch circuit is not closed. Induced draft blower is operating. Furnace is operating on low stage only 	PS2 OPEN	E9	<ul style="list-style-type: none"> Pressure switch hose blocked pinched, or connected improperly. Blocked flue or weak induced draft blower. Incorrect pressure switch set point or malfunctioning switch contacts. Loose or improperly connected wiring. 	<ul style="list-style-type: none"> Inspect pressure switch hose. Repair/replace if necessary. Inspect flue for blockage, proper length, elbows, and termination. Correct as necessary. Check induced draft blower performance. Correct as necessary. Correct pressure switch set point or contact motion. Tighten or correct wiring connection. 	<ul style="list-style-type: none"> Turn power OFF prior to repair. Replace pressure switch with proper replacement part. Replace induced draft blower with proper replacement part.
<ul style="list-style-type: none"> Furnace fails to operate. Integrated control module LED display provides EA error code. ComfortNet™ thermostat "Call for Service" icon illuminated. ComfortNet™ thermostat scrolls "Check Furnace" message. 	EA	<ul style="list-style-type: none"> Polarity of 115 volt AC is reversed 	REVERSED PLTY	EA	<ul style="list-style-type: none"> Polarity of 115 volt AC power to furnace or integrated module is reversed. Poor unit ground 	<ul style="list-style-type: none"> Review wiring diagram to correct polarity. Verify proper ground. Correct if necessary. Check and correct wiring. 	<ul style="list-style-type: none"> Turn power OFF prior to repair.
<ul style="list-style-type: none"> Integrated control module LED display EF error code. ComfortNet™ thermostat "Call for Service". 	EF	<ul style="list-style-type: none"> Aux switch open 	Aux Alarm Fault	EF	<ul style="list-style-type: none"> High water level in the evaporation coil. 	<ul style="list-style-type: none"> Check overflow pan and service. 	<ul style="list-style-type: none"> Turn power OFF prior to service.
<ul style="list-style-type: none"> Furnace fails to operate. Integrated control module LED display provides d0 error code. ComfortNet™ thermostat "Call for Service" icon illuminated. ComfortNet™ thermostat scrolls "Check Furnace" message. 	d0	<ul style="list-style-type: none"> Data not yet on network. 	NO NET DATA	d0	<ul style="list-style-type: none"> Furnace does not contain any shared data. 	<ul style="list-style-type: none"> Populate shared data set using memory card. 	<ul style="list-style-type: none"> Turn power OFF prior to repair Use memory card for the specific model. Insert memory card BEFORE turning power ON. Memory card may be removed after data is loaded and power is turned off. Error code will be cleared once data is loaded.

TROUBLESHOOTING CHART

Symptoms of Abnormal Operation (Legacy & ComfortNet™ Thermostat)	Diagnostic/Status LED Codes	Fault Description	ComfortNet™ Thermostat Only		Possible Causes	Corrective Actions	Notes & Cautions
			Message	Code			
<ul style="list-style-type: none"> • Operation different than expected or no operation. • Integrated control module LED display provides d4 error code. • ComfortNet™ thermostat "Call for Service" icon illuminated. • ComfortNet™ thermostat scrolls "Check Furnace" message. 	d4	<ul style="list-style-type: none"> • Invalid memory card data. 	INVALID MC DATA	d4	<ul style="list-style-type: none"> • Shared data set on memory card has been rejected by integrated control module. 	<ul style="list-style-type: none"> • Verify shared data set is correct for the specific model. Re-populate data using correct memory card if required. 	<ul style="list-style-type: none"> • Turn power OFF prior to repair. • Use memory card for the specific model. • Insert memory card BEFORE turning power ON. Memory card may be removed after data is loaded and power is turned off. • Error code will be cleared once data is loaded and power is turned off.
<ul style="list-style-type: none"> • Furnace fails to operate. • Integrated control module LED display provides b0 error code. • ComfortNet™ thermostat "Call for Service" icon illuminated. • ComfortNet™ thermostat scrolls "Check Furnace" message. 	b0	<ul style="list-style-type: none"> • Circulator blower motor is not running when it should be running. 	MOTOR NOT RUN	b0	<ul style="list-style-type: none"> • Loose wiring connection at circulator motor power leads or circulator motor power leads disconnected. • Open circuit in inductor or loose wiring connection at inductor (3/4 Hp and 1 Hp models only). • Failed circulator blower motor. 	<ul style="list-style-type: none"> • Tighten or correct wiring connection. • Verify continuous circuit through inductor. Replace if open or short circuit. • Check circulator blower motor. Replace if necessary. 	<ul style="list-style-type: none"> • Turn power OFF prior to repair. • Replace inductor with correct replacement part. • Replace circulator motor with correct replacement part.
<ul style="list-style-type: none"> • Furnace fails to operate. • Integrated control module LED display provides b1 error code. • ComfortNet™ thermostat "Call for Service" icon illuminated. • ComfortNet™ thermostat scrolls "Check Furnace" message. 	b1	<ul style="list-style-type: none"> • Integrated control module has lost communications with circulator blower motor. 	MOTOR COMM	b1	<ul style="list-style-type: none"> • Loose wiring connection at circulator motor control leads. • Failed circulator blower motor. • Failed integrated control module. 	<ul style="list-style-type: none"> • Tighten or correct wiring connection. • Check circulator blower motor. Replace if necessary. • Check integrated control module. Replace if necessary. 	<ul style="list-style-type: none"> • Turn power OFF prior to repair. • Replace circulator motor with correct replacement part. • Replace integrated control module with correct replacement part.
<ul style="list-style-type: none"> • Furnace fails to operate. • Integrated control module LED display provides b2 error code. • ComfortNet™ thermostat "Call for Service" icon illuminated. • ComfortNet™ thermostat scrolls "Check Furnace" message. 	b2	<ul style="list-style-type: none"> • Circulator blower motor horse power in shared data set does not match circulator blower motor horse power. 	MOTOR MISMATCH	b2	<ul style="list-style-type: none"> • Incorrect circulator blower motor in furnace. • Incorrect shared data set in integrated control module. 	<ul style="list-style-type: none"> • Verify circulator blower if motor horse power is the same specified for the specific furnace model. Replace if necessary. • Verify shared data set is correct for the specific model. Re-populate data using correct memory card if required. 	<ul style="list-style-type: none"> • Turn power OFF prior to repair. • Replace motor with correct replacement part. • Use memory card for the specific model. • Insert memory card BEFORE turning power ON. Memory card may be removed after data is loaded and power is turned off. • Error code will be cleared once shared data and motor horse power match.
<ul style="list-style-type: none"> • Furnace operates at reduced performance. • Airflow delivered is less than expected. • Integrated control module LED display provides b3 error code. 	b3	<ul style="list-style-type: none"> • Circulator blower motor is operating in a power, temperature, or speed limiting condition. 	MOTOR LIMITS	b3	<ul style="list-style-type: none"> • Blocked filters. • Restrictive ductwork. • Undersized ductwork. • High ambient temperatures. 	<ul style="list-style-type: none"> • Check filters for blockage. Clean filters or remove obstruction. • Check ductwork for blockage. Remove obstruction. Verify all registers are fully open. • Verify ductwork is appropriately sized for system. Resize/replace ductwork if necessary. • See "III. Product Description" and "IV. Location Requirements & Considerations" furnace installation requirements. 	<ul style="list-style-type: none"> • Turn power OFF prior to repair.

TROUBLESHOOTING CHART

Symptoms of Abnormal Operation (Legacy & ComfortNet™ Thermostat)	Diagnostic/Status LED Codes	Fault Description	ComfortNet™ Thermostat Only		Possible Causes	Corrective Actions	Notes & Cautions
			Message	Code			
<ul style="list-style-type: none"> Furnace fails to operate. Integrated control module LED display provides b4 error code. ComfortNet™ thermostat "Call for Service" icon illuminated. ComfortNet™ thermostat scrolls "Check Furnace" message. 	b4	<ul style="list-style-type: none"> Circulator blower motor senses a loss of rotor control. Circulator blower motor senses high current. 	MOTOR TRIPS	b4	<ul style="list-style-type: none"> Abnormal motor loading, sudden change in speed or torque, sudden blockage of furnace air inlet or outlet. 	<ul style="list-style-type: none"> Check filters, filter grills/registers, duct system, and furnace air inlet/outlet for blockages. 	<ul style="list-style-type: none"> Turn power OFF prior to repair.
<ul style="list-style-type: none"> Furnace fails to operate. Integrated control module LED display provides b5 error code. ComfortNet™ thermostat "Call for Service" icon illuminated. ComfortNet™ thermostat scrolls "Check Furnace" message. 	b5	<ul style="list-style-type: none"> Circulator blower motor fails to start 10 consecutive times. 	MOTOR LCKD ROTOR	b5	<ul style="list-style-type: none"> Obstruction in circulator blow housing. Seized circulator blower motor bearings. Failed circulator blower motor. 	<ul style="list-style-type: none"> Check circulator blower for obstructions. Remove and repair/replace wheel/motor if necessary. Check circulator blower motor shaft rotation and motor. Replace motor if necessary. 	<ul style="list-style-type: none"> Turn power OFF prior to repair. Replace motor with correct replacement part. Replace wheel with correct replacement part.
<ul style="list-style-type: none"> Furnace fails to operate. Integrated control module LED display provides b6 error code. ComfortNet™ thermostat "Call for Service" icon illuminated. ComfortNet™ thermostat scrolls "Check Furnace" message. 	b6	<ul style="list-style-type: none"> Circulator blower motor shuts down for over or under voltage condition. Circulator blower motor shuts down due to over temperature condition on power module. 	MOTOR VOLTS	b6	<ul style="list-style-type: none"> High AC line voltage to furnace. Low AC line voltage to furnace. High ambient temperatures. 	<ul style="list-style-type: none"> Check power to furnace. Verify line voltage to furnace is within the range specified on the furnace rating plate. See "III. Product Description" and "IV. Location Requirements & Considerations" furnace installation requirements. 	<ul style="list-style-type: none"> Turn power OFF prior to repair.
<ul style="list-style-type: none"> Furnace fails to operate. Integrated control module LED display provides b7 error code. ComfortNet™ thermostat "Call for Service" icon illuminated. ComfortNet™ thermostat scrolls "Check Furnace" message. 	b7	<ul style="list-style-type: none"> Circulator blower motor does not have enough information to operate properly. Motor fails to start 40 consecutive times. 	MOTOR PARAMS	b7	<ul style="list-style-type: none"> Error with integrated control module. Motor has a locked rotor condition. 	<ul style="list-style-type: none"> Check integrated control module. Verify control is populated with correct shared data set. See data errors above for details. Check for locked rotor condition (see error code above for details). 	<ul style="list-style-type: none"> Turn power OFF prior to repair. Replace with correct replacement part(s). Use memory card for the specific model.
<ul style="list-style-type: none"> Furnace operates at reduced performance or operates on low stage when high stage is expected. Integrated control module LED display provides b9 error code. 	b9	<ul style="list-style-type: none"> Airflow is lower than demanded. 	LOW ID AIRFLOW	B9	<ul style="list-style-type: none"> Blocked filters. Restrictive ductwork. Undersized ductwork. 	<ul style="list-style-type: none"> Check filters for blockage. Clean filters or remove obstruction. Check ductwork for blockage. Remove obstruction. Verify all registers are fully open. Verify ductwork is appropriately sized for system. Resize/replace ductwork if necessary. 	<ul style="list-style-type: none"> Turn power OFF prior to repair.

STATUS CODES

<input type="checkbox"/>	<input type="checkbox"/>	INTERNAL CONTROL FAULT/NO POWER
<input type="checkbox"/>	<input type="checkbox"/>	NORMAL OPERATION
<input type="checkbox"/>	<input type="checkbox"/>	LOCKOUT DUE TO EXCESSIVE RETRIES
<input type="checkbox"/>	<input type="checkbox"/>	LOW STAGE PRESSURE SWITCH STUCK CLOSED AT START OF HEATING CYCLE
<input type="checkbox"/>	<input type="checkbox"/>	LOW STAGE PRESSURE SWITCH STUCK OPEN
<input type="checkbox"/>	<input type="checkbox"/>	OPEN HIGH LIMIT SWITCH
<input type="checkbox"/>	<input type="checkbox"/>	FLAME DETECTED WHEN NO FLAME SHOULD BE PRESENT
<input type="checkbox"/>	<input type="checkbox"/>	OPEN FUSE
<input type="checkbox"/>	<input type="checkbox"/>	LOW FLAME SIGNAL
<input type="checkbox"/>	<input type="checkbox"/>	IGNITER FAULT OR IMPROPER GROUNDING
<input type="checkbox"/>	<input type="checkbox"/>	HIGH STAGE PRESSURE SWITCH STUCK CLOSED AT START OF HEATING CYCLE
<input type="checkbox"/>	<input type="checkbox"/>	HIGH STAGE PRESSURE SWITCH STUCK OPEN
<input type="checkbox"/>	<input type="checkbox"/>	REVERSED 115 VAC POLARITY
<input type="checkbox"/>	<input type="checkbox"/>	AUXILIARY SWITCH OPEN
<input type="checkbox"/>	<input type="checkbox"/>	DATA NOT YET ON NETWORK
<input type="checkbox"/>	<input type="checkbox"/>	INVALID MEMORY CARD DATA
<input type="checkbox"/>	<input type="checkbox"/>	BLOWER MOTOR NOT RUNNING
<input type="checkbox"/>	<input type="checkbox"/>	BLOWER COMMUNICATION ERROR
<input type="checkbox"/>	<input type="checkbox"/>	BLOWER HP MIS-MATCH
<input type="checkbox"/>	<input type="checkbox"/>	BLOWER MOTOR OPERATING IN POWER, TEMPERATURE, OR SPEED LIMIT
<input type="checkbox"/>	<input type="checkbox"/>	BLOWER MOTOR CURRENT TRIP OR LOST ROTOR
<input type="checkbox"/>	<input type="checkbox"/>	BLOWER MOTOR LOCKED ROTOR
<input type="checkbox"/>	<input type="checkbox"/>	OVER/UNDER VOLTAGE TRIP OR OVER TEMPERATURE TRIP
<input type="checkbox"/>	<input type="checkbox"/>	INCOMPLETE PARAMETERS SENT TO MOTOR
<input type="checkbox"/>	<input type="checkbox"/>	LOW INDOOR AIRFLOW
<input type="checkbox"/>	<input type="checkbox"/>	LOW STAGE COOL
<input type="checkbox"/>	<input type="checkbox"/>	HIGH STAGE COOL
<input type="checkbox"/>	<input type="checkbox"/>	LOW STAGE HEAT PUMP HEAT
<input type="checkbox"/>	<input type="checkbox"/>	HIGH STAGE HEAT PUMP HEAT
<input type="checkbox"/>	<input type="checkbox"/>	LOW STAGE GAS HEAT
<input type="checkbox"/>	<input type="checkbox"/>	HIGH STAGE GAS HEAT
<input type="checkbox"/>	<input type="checkbox"/>	CONTINUOUS FAN
<input type="checkbox"/>	<input type="checkbox"/>	CFM/100; ALTERNATES WITH <input type="checkbox"/> <input type="checkbox"/> 1, <input type="checkbox"/> <input type="checkbox"/> 2, <input type="checkbox"/> <input type="checkbox"/> LO, <input type="checkbox"/> <input type="checkbox"/> HI, <input type="checkbox"/> <input type="checkbox"/> F
		<input type="checkbox"/> <input type="checkbox"/> 1, <input type="checkbox"/> <input type="checkbox"/> 2

0140F01169 REV A

AIRFLOW DATA

MODEL	TAP	Low Stage Cool	High Stage Cool	Low Stage Heat	High Stage Heat	MODEL	TAP	Low Stage Cool	High Stage Cool	Low Stage Heat	High Stage Heat			
DC80VC0603B***	A	412	631	784	1107	DM80VC0603B***	A	468	698	735	1012			
	B	570	839	851	1198		B	584	847	804	1098			
	C	718	1050	922	1316		C	738	1034	874	1201			
	D	842	1239	981	1407		D	872	1253	934	1310			
DC80VC0803B***	A	423	643	690	937	DM80VC0604B***	A	390	600	875	1250			
	B	582	782	743	1045		B	520	800	945	1350			
	C	690	982	807	1155		C	715	1100	1015	1450			
	D	802	1200	870	1254		D	910	1400	1085	1550			
DC80VC0805C***	A	532	817	976	1401	DM80VC0803B***	A	465	730	735	1012			
	B	732	1123	1048	1495		B	584	878	804	1098			
	C	942	1445	1121	1579		C	780	1056	874	1201			
	D	1197	1861	1192	1684		D	924	1224	934	1310			
DC80VC1005C***	A	556	848	1150	1591	DM80VC0804C***	A	588	857	908	1234			
	B	838	1177	1188	1646		B	742	1051	986	1365			
	C	1031	1480	1211	1702		C	878	1284	1061	1501			
	D	1299	1881	1284	1790		D	1049	1616	1142	1618			
Speed Selection Dip Switches						DM80VC0805C***	A	520	800	1050	1500			
Cool Selection Switches		Adjust Selection Switches		Profile Selection Switches			Heat Selection Switches		B	715	1100	1120	1600	
Tap	S3- 1	S3- 2	S3- 3	S3- 4	S4-1		S4-2	S4- 3	S4-4	C	910	1400	1190	1700
A	OFF	OFF	OFF	OFF	OFF		OFF	OFF	OFF	D	1170	1800	1260	1800
B	ON	OFF	ON	OFF	ON	OFF	ON	OFF	DM80VC0805D***	A	582	830	1386	1998
C	OFF	ON	OFF	ON	OFF	ON	OFF	ON		B	786	1139	1405	2007
D	ON	ON	ON	ON	ON	ON	ON	ON		C	1047	1561	1415	2022
Profile	Pre-Run		Short Run		Off Delay					D	1326	1966	1435	2047
A	----		----		60 sec @100%				DM80VC1005C***	A	520	800	1210	1725
B	----		30sec @ 50%		60 sec @100%					B	715	1100	1225	1750
C	----		7.5 min @82%		60 sec @100%					C	910	1400	1245	1775
D	30 sec @ 50%		7.5 min @82%		30 sec @ 50%					D	1170	1800	1260	1800
<p>To Set Airflow: (1) Select model and desired High Stage Cooling Airflow. Determine the corresponding tap (A, B, C, or D). Set dip switches S3-1* and S3-2* to the appropriate ON / OFF positions. (2) Select model and desired High Stage Heating Airflow. Determine the corresponding tap (A, B, C, or D). Set dip switches S4-3* and S4-4* to the appropriate ON / OFF positions. (3) Selecting Airflow Adjustment Factor: For 0% trim set S5-2* to OFF (trim disabled). If trim is desired set S5-2* to ON (trim enabled) and set S3-3* and S3-4* to appropriate ON / OFF positions. Tap A is +5%, Tap B is -5%, Tap C is +10%, Tap D is -10%. To Set Comfort Mode: Select Desired Comfort Mode profile (see profiles above). Set dip switches S4-1* and S4-2* to the appropriate ON / OFF positions. Dehumidification: To enable, set switch S5-1* to ON. Cooling airflow will be reduced to 85% of nominal value during cool call. To disable, set switch S5-1* to OFF. Continuous Fan Speed: Set dip switches S5-3* and S5-4* to select one of 4 continuous fan speeds (25%, 50%, 75%, or 100%). " See installation manual for details" *the "S" number refers to one of four labeled dip switch section each containing 4 individual dip switches. The following number refers to the individual labeled dip switch within that section</p>														

DIP SWITCHES

Switch Bank	Purpose	Function	Dip Switch			
			1	2	3	4
S1	Heating Off Delay	90	Off	Off		
		120	On	Off		
		150	Off	On		
		180	On	On		
	Thermostat Setup	2 Stage Stat			On	On
		1 Stg Stat 5 min delay			Off	Off
		1 Stg Stat auto delay			Off	On
S3	Cooling Airflow	A	Off	Off		
		B	On	Off		
		C	Off	On		
		D	On	On		
	Trim	Add 5%			Off	Off
		Minus 5%			On	Off
		Add 10%			Off	On
		Minus 10%			On	On
S4	Ramping Profile	A	Off	Off		
		B	On	Off		
		C	Off	On		
		D	On	On		
	Heating Airflow	A			Off	Off
		B			On	Off
		C			Off	On
		D			On	On
S5	Dehum	Disabled	Off			
		Enabled	On			
	Trim	Disabled		Off		
		Enabled		On		
	Continuous Fan	25%			Off	Off
		50%			On	Off
		75%			Off	On
		100%			On	On

WIRING DIAGRAM

DM80VC / DC80VC

WARNING
HIGH VOLTAGE!
 DISCONNECT ALL POWER BEFORE SERVICING OR INSTALLING THIS UNIT.
 MULTIPLE POWER SOURCES MAY BE PRESENT. FAILURE TO DO SO MAY
 CAUSE PROPERTY DAMAGE, PERSONAL INJURY OR DEATH.

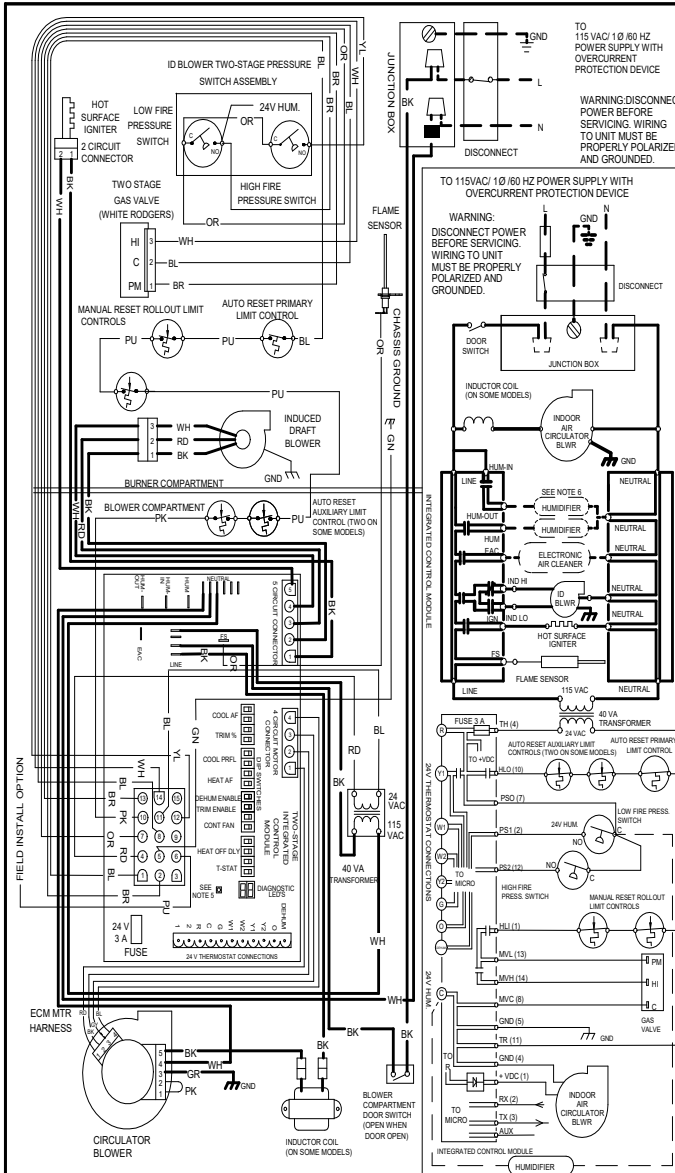

MODEL	TAP	Low Stage Cool	High Stage Cool	Low Stage Heat	High Stage Heat
DC80VC0603B***	A	412	631	784	1107
	B	570	839	851	1198
	C	718	1050	922	1316
	D	842	1239	981	1407
DC80VC0803B***	A	423	643	690	937
	B	582	782	743	1045
	C	690	982	807	1155
	D	802	1200	870	1254
DC80VC0805C***	A	532	817	976	1401
	B	732	1123	1048	1495
	C	942	1445	1121	1570
	D	1197	1861	1192	1684
DC80VC1005C***	A	556	848	1150	1591
	B	838	1177	1188	1646
	C	1031	1480	1211	1792
	D	1299	1881	1284	1790

Speed Selection Dip Switches

Model	Tap	Col Selection	Adj Selection	Substn	Profile Selection	Heat Selection
DM80VC0805C***	A	S3-1	S3-2	S3-3	S4-1	S4-2
	B	S3-1	S3-3	S3-4	S4-1	S4-3
	C	S3-1	S3-3	S3-4	S4-1	S4-4
	D	S3-1	S3-3	S3-4	S4-1	S4-4
DM80VC0805D***	A	OFF	OFF	OFF	OFF	OFF
	B	ON	OFF	ON	OFF	ON
	C	OFF	ON	OFF	ON	OFF
	D	ON	ON	ON	ON	ON
DM80VC1005C***	A	---	---	---	---	---
	B	---	30 sec @ 50%	---	---	60 sec @ 100%
	C	---	7.5 min @ 82%	---	---	60 sec @ 100%
	D	30 sec @ 50%	7.5 min @ 82%	---	---	30 sec @ 50%

To Set Airflow: (1) Select model and desired High Stage Cooling Airflow. Determine the corresponding tap (A, B, C, or D). Set dip switches S3-1* and S3-2* to the appropriate ON / OFF positions. (2) Select model and desired High Stage Heating Airflow. Determine the corresponding tap (A, B, C, or D). Set dip switches S4-3* and S4-4* to the appropriate ON / OFF positions. (3) Selecting Airflow Adjustment Factor: For 0% trim set S5-2* to OFF (trim disabled). If trim is desired set S5-2* to ON (trim enabled) and set S3-3* and S3-4* to appropriate ON / OFF positions. Tap A is +5%, Tap B is -5%, Tap C is +10%, Tap D is -10%. To Set Comfort Mode: Select Desired Comfort Mode profile (see profiles above). Set dip switches S4-1* and S4-2* to the appropriate ON / OFF positions. Dehumidification: To enable, set switch S5-1* to ON. Cooling airflow will be reduced to 85% of nominal value during cool call. To disable, set switch S5-1* to OFF. Continuous Fan Speed: Set dip switches S5-3* and S5-4* to select one of 4 continuous fan speeds (25%, 50%, 75%, or 100%). * See installation manual for details. The "S" number refers to one of four labeled dip switch sections each containing 4 individual dip switches. The following number refers to the individual labeled dip switch within that section.

This furnace must be installed in accordance with the manufacturer's instructions and local codes. In the absence of local codes, follow the National Fuel Gas Codes: ANSI Z223.1, or CAN/CGA-b149 Installation Codes. Ce générateur d'air chaud doit être installé conformément aux instructions du fabricant et aux codes locaux. En l'absence de code local, respecter la norme ANSI Z223.1, intitulé National Fuel Gas Code ou les codes d'installation CAN/CGA-b149.

Minimum Clearance to Combustible Materials in Alcove or Closet installations (in.)
 Dégagements minimum des matériaux pour une installation en alcôve ou en amoire (en pouces)

Position	Sides	Front	Rear	Top	Bottom	Vent
Upflow/Courant ascendant	1	3	0	1	+	1 W/B1/6 Single wall connector
Counter Flow/Contre-courant	1	3	0	1	#	1 W/B1/6 Single wall connector
Horizontal/Horizontale	1	Alcove	0	1	+	1 W/B1/6 Single wall connector

Line contact only permissible between lines formed by intersections of top and two sides of furnace jacket, and building joists, studs or framing. Les seuls points de contact admissible se trouvent entre les lignes formées par les intersections du dessus et des deux côtés de l'enveloppe du générateur d'air chaud, et les soliviers, les poutres ou la charpente du bâtiment.

1) All positioning is determined as installed unit is view from front.
 Tous les positions sont déterminées telles que vues de l'avant de l'appareil installé.

2) Allow 24" minimum service clearance.
 Prévoir un dégagement minimum de 24" pouces pour les interventions de dépannage.

+ For installation on combustible flooring.
 Installer sur un plancher combustible.

For installation on non combustible flooring only.
 Installer sur un plancher non combustible seulement.

* For installation on combustible flooring only when installed on special base Part no.
 Pour les planchers combustibles, n'installer que sur les socle spécial n°.

Part Number	Chassis Width
SBT 14	15
SBT 17	17.5
SBT 21	21

For use with natural gas and propane. A conversion kit as supplied by the manufacturer, shall be used to convert this furnace to the alternate fuel. Pour utilisation avec le gaz naturel et le propane. Une trousse de conversion fournie par le fabricant doit être utilisée pour passer d'un combustible à l'autre.

COLOR CODES:	LOW VOLTAGE (24V)	HI VOLTAGE (115V)	JUNCTION	INTERNAL TO INTEGRATED CONTROL	PLUG CONNECTION
YL YELLOW	---	---	---	---	---
OR ORANGE	---	---	---	---	---
PK PINK	---	---	---	---	---
BR BROWN	---	---	---	---	---
PU PURPLE	---	---	---	---	---
WH WHITE	---	---	---	---	---
GR GREEN	---	---	---	---	---
BL BLUE	---	---	---	---	---
GY GRAY	---	---	---	---	---
BK BLACK	---	---	---	---	---
RD RED	---	---	---	---	---

NOTES:

- SET HEAT ANTICIPATOR ON ROOM THERMOSTAT AT 0.7 AMPS.
- MANUFACTURER'S SPECIFIED REPLACEMENT PARTS MUST BE USED WHEN SERVICING.
- IF ANY OF THE ORIGINAL WIRE AS SUPPLIED WITH THE FURNACE MUST BE REPLACED, IT MUST BE REPLACED WITH WIRING MATERIAL HAVING A TEMPERATURE RATING OF AT LEAST 105°C. USE COPPER CONDUCTORS ONLY.
- UNIT MUST BE PERMANENTLY GROUNDED AND CONFORM TO N.E.C. AND LOCAL CODES.
- TO RECALL THE LAST 6 FAULTS, MOST RECENT TO LEAST RECENT, DEPRESS SWITCH FOR MORE THAN 2 SECONDS WHILE IN STANDBY (NO THERMOSTAT INPUTS).
- HUMIDIFIER INSTALLATION OPTIONS: USE HUM TERMINAL TO RUN HUMIDIFIER DURING HEAT CALL (COMMUNICATING OR LEGACY MODES). USE HUM-IN AND HUM-OUT TERMINALS TO RUN HUMIDIFIER DURING HEAT CALL (COMMUNICATING MODE OR LEGACY MODE) OR INDEPENDENTLY FROM HEAT CALL (COMMUNICATING MODE ONLY - SETUP IS DONE WITHIN COMMUNICATING THERMOSTAT)

0	INTERNAL CONTROL FAULT/NO POWER	4	INVALID MEMORY CARD
1	NORMAL OPERATION	5	BLOWER MOTOR NOT RUNNING
2	LOCKOUT DUE TO EXCESSIVE RETRIES	6	BLOWER COMMUNICATION ERROR
3	LOW STAGE PRESSURE SWITCH CLOSED AT START OF HEATING CYCLE	7	BLOWER HP MIS-MATCH
4	LOW STAGE PRESSURE SWITCH OPEN	8	BLOWER MOTOR OPERATING IN POWER
5	HIGH LIMIT SWITCH	9	TEMPERATURE OR SPEED LIMIT
6	FLAME DETECTED WHEN NO FLAME SHOULD BE PRESENT	10	BLOWER MOTOR CURRENT TRIP OR LOST ROTOR
7	OPEN FUSE	11	BLOWER MOTOR LOCKED ROTOR
8	LOW FLAME SIGNAL	12	OVERUNDER VOLTAGE TRIP OR OVER
9	IGNITER FAULT OR IMPROPER GROUNDING	13	TEMPERATURE TRIP
10	HIGH STAGE PRESSURE SWITCH CLOSED AT START OF HEATING CYCLE	14	INCOMPLETE PARAMETERS SENT TO MOTOR
11	HIGH STAGE PRESSURE SWITCH OPEN	15	LOW INDOOR AIRFLOW
12	REVERSED 115 VAC POLARITY	16	LOW STAGE COOL
13	AUXILIARY SWITCH OPEN	17	HIGH STAGE COOL
14	DATA NOT YET ON NETWORK	18	LOW STAGE HP HEAT
		19	HIGH STAGE HP HEAT
		20	LOW STAGE GAS HEAT
		21	HIGH STAGE GAS HEAT
		22	FAN
		23	CFM/100 ALTERNATES WITH C1, C2, LO, HI, F P1, P2

Wiring is subject to change. Always refer to the wiring diagram on the unit for the most up-to-date wiring.

START-UP CHECKLIST

Furnace			
	Model Number	_____	
	Serial Number	_____	
ELECTRICAL			
Line Voltage (Measure L1 to N and N to Ground Voltage)	L - N	_____	
	N - G	_____	
Secondary Voltage (Measure Transformer Output Voltage)	R - C	_____	
Blower Amps		_____	
BLOWER EXTERNAL STATIC PRESSURE			
Return Air Static Pressure		_____	IN. W.C.
Supply Air Static Pressure		_____	IN. W.C.
Total External Static Pressure (Ignoring +/- from the reading above, add total here)		_____	IN. W.C.
TEMPERATURES			
Return Air Temperature (Dry bulb / Wet bulb)	_____	DB °F	_____ WB °F
Cooling Supply Air Temperature (Dry bulb / Wet bulb)	_____	DB °F	_____ WB °F
Heating Supply Air Temperature	_____	DB °F	
Temperature Rise	_____	DB °F	
Delta T (Difference between Supply and Return Temperatures)	_____	DB °F	
GAS PRESSURES			
Gas Inlet Pressure		_____	IN. W.C.
Gas Manifold Pressure (Low Fire)		_____	IN. W.C.
Gas Manifold Pressure (High Fire)		_____	IN. W.C.
Gas Type (NG) = Natural Gas / (LP) = Liquid Propane		_____	
Additional Checks			
Check wire routings for any rubbing		_____	
Check for kinked pressure switch tubing.		_____	
Check flue elbow for alignment and clamp tightness.		_____	
Check screw tightness on blower wheel.		_____	
Check factory wiring and wire connections.		_____	
Check product for proper clearances as noted by installtion instructions		_____	
°F to °C formula: (°F - 32) divided by 1.8 = °C °C to °F formula: (°C multiplied by 1.8) + 32 = °F			

CUSTOMER FEEDBACK

Daikin Comfort Technologies is very interested in all product comments.

Please fill out the feedback form on the following link:

<https://daikincomfort.com/contact-us>

You can also scan the QR code on the right to be directed to the feedback page.



PRODUCT REGISTRATION

Thank you for your recent purchase. Though not required to get the protection of the standard warranty, registering your product is a relatively short process, and entitles you to additional warranty protection, except that failure by California and Quebec residents to register their product does not diminish their warranty rights. The duration of warranty coverages in Texas and Florida differs in some cases.

For Product Registration, please register by following this link:

<https://daikincomfort.com/owner-support/product-registration>

You can also scan the QR code on the right to be directed to the Product Registration page.



Our continuing commitment to quality products may mean a change in specifications without notice.

© 2013-2019, 2021, 2023 **DAIKIN COMFORT TECHNOLOGIES MANUFACTURING, L.P.**

19001 Kermier Rd., Waller, TX 77484

www.daikincomfort.com