

R-410A or R-32

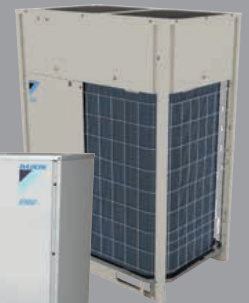

VRV COMMERCIAL PRODUCTS

CATALOG

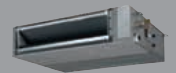
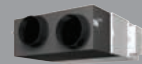
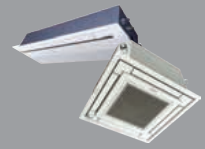

# Table of Contents

## Overview

Why choose Daikin?	4
What is Daikin VRV?	5
Why choose Daikin VRV?	6
Which VRV System Offers the Best Solution?	7
Setting the Standards	8
Daikin VRV	10
Setting the Standards, Again	12
What does a VRV installation mean to you?	24
Vertical Market Applications	26

## Product Portfolio

Outdoor Units	29
Indoor Units	30
Accessories and Controls	34

## Indoor units

### Indoor Units Overview

#### Indoor Units (R-410A)

FXMQ_TBVJU - HSP DC Concealed Ducted Unit	52
FXSQ_TBVJU - MSP Concealed Ducted Unit	54
FXDQ_MVJU - LSP Slim Concealed Ducted Unit	56
FXTQ_TBVJUA(D) Multi-Position Air Handling Unit	58
FXMQ_MVJU - HSP High Capacity Concealed Ducted Unit	60
FXNQ_MVJU9 - Concealed Floor-Standing Unit	62
FXFO_AAVJU - Round Flow Sensing Cassette	64
FXUQ_PAVJU - 4-Way Ceiling-Suspended Cassette	68
FXZQ_TBVJU - VISTA 2x2 Cassette	70
FXEQ_PVJU - Ceiling-Mounted Cassette	72
FXHQ_MVJU - Ceiling-Suspended Unit	74
FXAQ_PVJU - Wall-Mounted Unit	76
FXLQ_MVJU9 - Floor-Standing Unit	78

#### Indoor Units (R-32)

FXFA_AAVJU - Round Flow Sensing Cassette	80
FXMA_AAVJU - HSP DC Concealed Ducted Unit	84
FXSA_AAJU - MSP Concealed Ducted Unit	86
FXTA_AAJU - Multi-Position Air Handling Unit	88
FXZA_AAVJU - MSP Concealed Ducted Unit	90
FXAA_AAVJU - Multi-Position Air Handling Unit	92
DZK Zoning Kit for VRV Indoor Units	94

## Outdoor units

### Outdoor Units (R-410A)

VRV EMERION - Air-Cooled Heat Recovery	98
VRV EMERION - Air-Cooled Heat Pump	102

### Outdoor Units (R-32)

VRV EMERION - Air-Cooled Heat Recovery	106
VRV EMERION - Air-Cooled Heat Pump	110

### Outdoor Units (R-410A)

VRV IV X - Air-Cooled Heat Recovery	114
High-Efficiency All-Electric Heat Pump Hot and Chilled Water Solutions	118
VRV IV X, VRV EMERION Indoor Units 80-97% AFUE Gas Furnace and VRV IV X	120
Daikin VRV AURORA Heat Recovery	122
Daikin VRV AURORA Heat Pump	126
VRV T-Series Water-Cooled Systems	130
VRV S-Series (R-32) Heat Pump	136
Installation Space –	
VRV EMERION, VRV IV X, VRV IV & VRV AURORA, VRV T-Series Water-Cooled, & VRV IV-S	138

Piping Length –	
VRV EMERION, VRV IV X, VRV IV & VRV AURORA, VRV T-Series Water-Cooled, & VRV IV-S Piping Length	140
VRV Accessories	142
Branch Selector Boxes	142
REFNET Pipe Joints	146
Hail Guard Kit	147
AHU (Air Handling Unit) Integration Kit	148
Control Box EKE_CBAV3-US	150

## Ventilation

FXMQ_MFVJU - 100% Outside Air Processing Unit	156
VAM-GVJU - Energy Recovery Ventilator	158

## Daikin MEGA-Q Hot Water Solutions

All-Electric Hot Water Generation Systems	162
Efficiency and Flexibility	163
How it Works	164

## Controls

VRV Controls Solution	168
VRV Controls Systems Overview	170
Individual Controllers	172
BRC1NRV71/72 (R-410A, R-32)	
Navigation Remote Controller	172
BRC1H71W - Madoka Remote Controller	176
DTST-CWBSA-NI-B - Daikin ONE+ Smart Thermostat	176
DTST-TOU-A ONE Touch Controller	176
AZAI6WSCDKA - DKN Cloud Wi-Fi Adaptor	176
BRC4C82/BRC7E818/BRC7E83/BRC7E830 - Wireless Remote Controller	177
Advanced Multi-Zone Controllers –	
HERO Pro Edge – Central Controller	
DGE601A71 - Daikin HERO Pro Edge	178
Advanced Multi-Zone Controllers	
DCM601B71 - intelligent Touch Manager (iTM)	183
External Equipment Control	185
DCM009A51 - iTM BACnet® Client Option	185
Interface Solutions	186
AZAI6WSPDKC - DKN Plus Interface	186
DCM014A51 - iTM BACnet Server Gateway Option	188
DCM007A51 - Web IF (HTTP) Software Option	190
DMS502B71 - Interface for use BACnet	190
DMS504C71 - Interface for LonWorks®	190
DTA116A51 - DIII-Net/Modbus® Adaptor	190
DTA118A72 - DIII-Net/BACnet MS/TP Communication Adaptor	190
HERO Cloud Service and HERO Simple Edge	191
HERO Cloud Service and HERO Pro Edge	193
HERO Cloud Services	195
Controls Product List	198

## Support and Tools

Support and tools overview	202
Selection software	204
Energy screening and simulation tools	204
Design and verification	205
Online and tablet reference material	205
Tech Hub reference	206
After sales and service	207

BACnet® is a trademark of ASHRAE.



## A history of industry-leading product innovation

Becoming a global leader in any industry takes more than just time. For over 95 years Daikin has shown that it takes industry-leading product innovation and a commitment to excellence in order to climb to the top. This commitment led Daikin to develop the first Variable Refrigerant Volume (VRV) system in 1982 and to become a pioneer with our Variable Refrigerant Volume systems.

## Daikin's 3 core technologies

Daikin is an industry-leading HVAC technology company. We develop state-of-the-art technology that provides indoor comfort solutions for our customers. We do this by focusing on 3 core technologies. Our refrigerant control technology provides an efficient and effective way to transport heat. Daikin inverter technology allows us to maximize energy efficiency and heat pump technology provides an effective method for moving refrigerant.

### Refrigerant control

Efficient heat transport

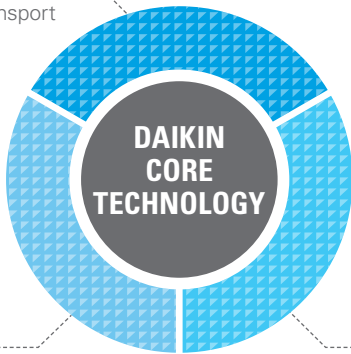

### Inverter

Contributes to greater energy savings and comfort

### Heat pump

Absorbs or removes heat from the air

## The total solution

Daikin's products and controls are designed to provide a flexible, scalable, total indoor comfort solution. We are committed to supporting our customers at every phase of the project to ensure that the highest quality and most cost effective solution is the one that is provided. From project conception throughout the life of an HVAC system, Daikin provides world class products and support. A single source and total solution for your HVAC requirements.

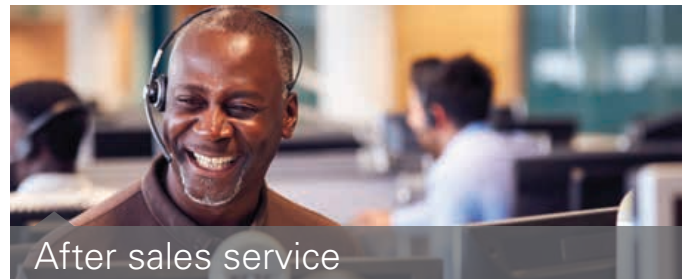

# What is Daikin VRV?

## One flexible package

Daikin VRV is a modular, commercially applied air-conditioning and heating system that distributes refrigerant from the outdoor unit to multiple indoor units, providing efficiency, comfortable individual user control and reliability in one flexible package.

Daikin VRV systems provide advanced solutions for almost any large residential to commercial application. Available in air-cooled or water-cooled solutions and heat recovery or heat pump systems, VRV provides advanced heating and cooling options with individual zone control for both open plan and tightly grouped applications.

VRV is built upon 5 basic "Building Blocks" — Outdoor Unit, Indoor Unit, Piping, Controls, and Ventilation — providing the attributes of a central chilled water system but with the simplicity of a split system. This makes it very

flexible and ideal for energy-efficient and comfortable cooling and heating of many types of buildings such as banks, health care, skilled care, libraries, storage facilities, conference centers, etc.



Outdoor Unit



Indoor Unit



Piping



Controls



Ventilation

### Applications

- » Multi-family residences
- » Retail
- » Hotels
- » Office buildings
- » Schools, etc.



## Inventor and leader in VRV systems since 1982

### Unique products that make the difference

#### » In efficiency

- Variable Refrigerant Temperature (VRT) technology leading to excellent energy efficiency
- Indoor units with advanced sensing technology and optional self-cleaning air filter panel

#### » In comfort

- Variable Refrigerant Temperature technology preventing cold draughts
- 16 different indoor unit types and 91 models
- Low sound indoor and outdoor units

#### » In aesthetics

- Stylish cassettes integrated in the ceiling
- Ceiling suspended cassettes
- Elegant wall mounted units

#### » In installation

- Self-addressing control system after installation
- VRV Configurator for simplified and time saving commissioning
- Flexible connection possibilities for indoor and outdoor units
- Service Window allows for easy commissioning and troubleshooting

#### » In control

- *intelligent Touch Manager (iTM)*— a mini-BMS/Centralized Controller that integrates all units in a cost-efficient system
- Easy integrating with third party BMS
- Dedicated control solutions for applications such as offices, shops, hotels, schools, etc.

#### » In system design

- User friendly sizing and selection software
- CAD drawings and Revit\* families
- Comprehensive engineering manuals

#### » In after market support

- Nationwide field support organization
- 50+ product training facilities in North America
- Dedicated tech support team

#### » In reliability

- Refrigerant-cooled electronics in outdoor unit
- Extensive testing before new units leave the factory
- Spare parts available in the US
- ISO 9001 compliant manufacturing
- One of the best warranties\*\* in the industry

\* Visit [bim.daikincity.com](http://bim.daikincity.com) for Revit families

\*\* Complete warranty details available from your local Daikin manufacturer's representative or distributor or online at [www.daikincomfort.com](http://www.daikincomfort.com).



# Which VRV System Offers the Best Solution?

## Air-cooled or water-cooled?

### Air-cooled

- » Fast and easy to install — no need for additional components
- » Low maintenance costs
- » Can be installed both outdoors and indoors
- » Up to 40 tons capacity for one system

Components:



Outdoor unit

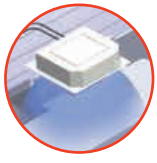

Indoor unit

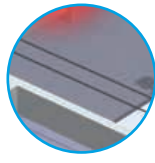

Refrigerant piping

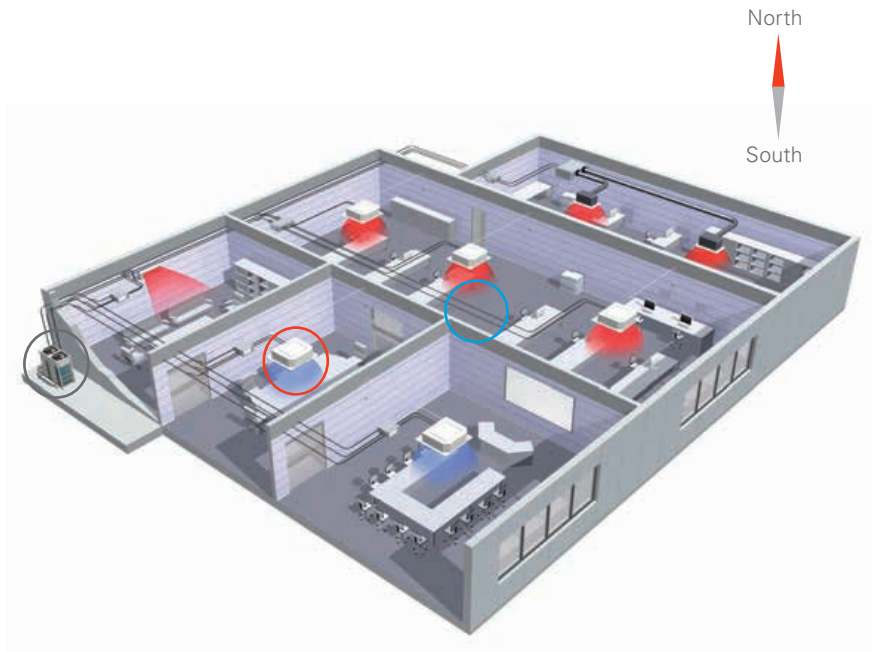

### Water-cooled

- » Suitable for multi-story and large buildings because of the almost unlimited possibilities of water piping
- » Not affected by outdoor temperature/climate conditions
- » Reduce CO<sub>2</sub> emissions thanks to the possibility of geothermal energy as a renewable energy source

Components:



Condensing unit

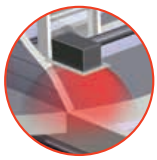

Indoor unit



Refrigerant piping



(Geothermal) water loop





## Heat Recovery or Heat Pump?

### VRV Heat Recovery

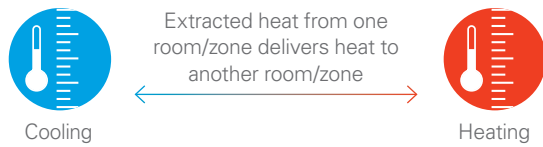

- » Simultaneous heating AND cooling from one system
- » Efficient heating by transferring heat rejected by cooling zones to those requiring heating.
- » Maximum individual comfort in all areas

Components:



Outdoor unit

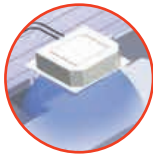

Indoor unit

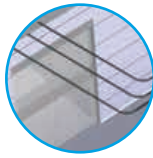

3-pipe refrigerant piping



Single and multi Branch Selector boxes: allows the individual switching of indoor units between heating and cooling

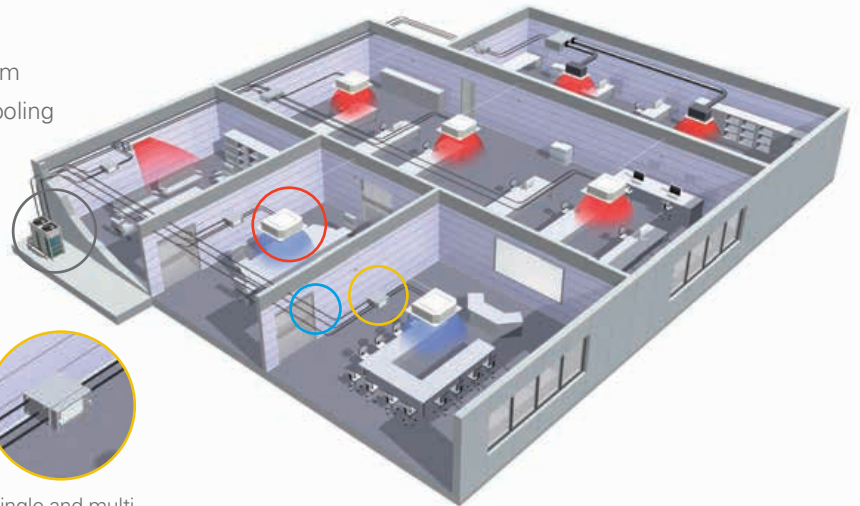

### VRV Heat Pump

- » For either heating OR cooling operation from one system

Components:



Outdoor unit



Indoor unit

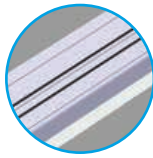

2-pipe refrigerant piping

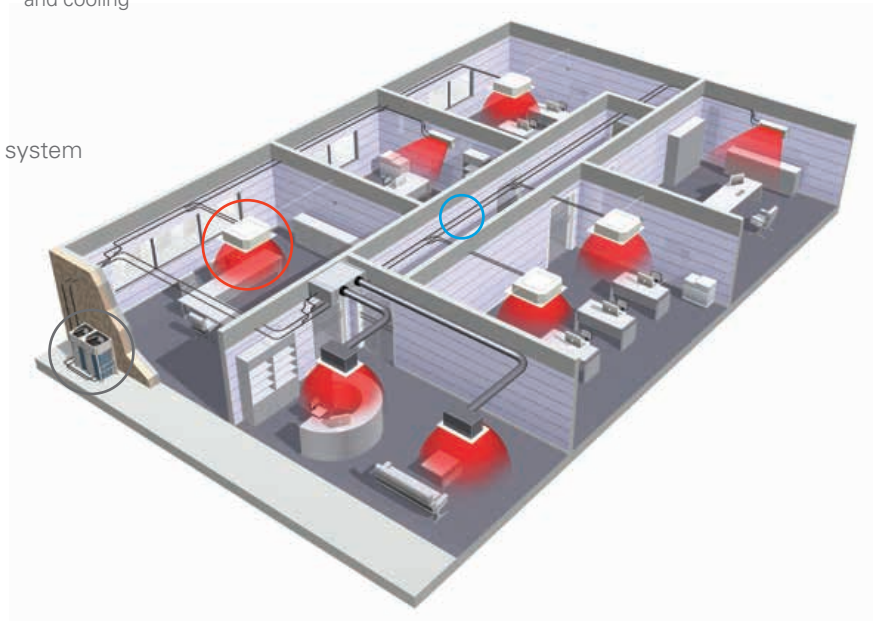

# Setting the Standards

## Over 40 years of VRV history

Daikin invented the first VRV system in 1982 and has continued to set standards in the industry and heighten market expectations. Many of the current market expectations are:

- » Energy efficient inverter compressor
- » Modular system concept
- » Heat recovery function
- » Allow long piping lengths
- » Heating operation down to -13°F ambient air temperature as standard
- » Continuous heat during defrost
- » Auto charge at start up

VRV was invented in 1982 as a result of the oil crisis around the world in the 70's. Energy efficiency laws were passed by the Japanese government. The Japanese government and Daikin worked closely together — they looked at a chiller system; pumps, and air handlers as well and how the pump circulates water and how it uses a lot of power. So, they came up with a concept to use refrigerant instead of water to circulate as a heat transfer medium. The first VRV heat recovery system was launched in 1991 implementing the landmark concept of a heat pump chiller that circulates refrigerant instead of water.



Our quality control is based on the idea that the added value we give to products is quality, and that this quality is what customers are buying. And each Daikin employee constantly puts quality ahead of everything else.



# Daikin VRV

Setting the Standards, Again



## Optimized life cycle cost



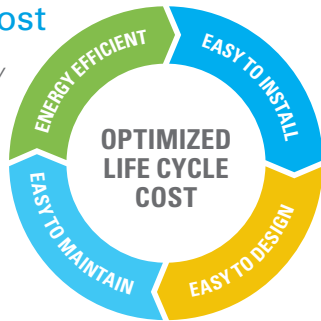





The features of a Daikin VRV system, energy efficient and easy to design, install, and maintain, means that it is designed to reduce the total life cycle cost.



## Optimized for the North American market needs

Engineered to be simple, sustainable and connected, VRV EMERION delivers an un-matched, all-electric heat recovery solution for new and existing commercial applications that are unique to the needs of North America HVAC Market. In addition, a long list of new and enhanced features and benefits make the new VRV EMERION system an ideal choice to address a wide range of commercial applications for owners, architects, engineers, and contractors.

VRV EMERION Heat Pump & Heat Recovery - Single and Dual modules

		CAPACITY - TONS (SINGLE MODULE)								
		6	8	10	12	14	16	18	20	
VRV EMERION Heat Pump & Heat Recovery										
			CAPACITY - TONS (DUAL MODULE)							
			22	24	26	28	30	40		
										

# Daikin VRV sets the standard with the latest technology and time saving commissioning & servicing

## Phased Installation

VRV EMERION and VRV IV X deliver enhanced design flexibility thanks to its ability to expand with the building's phased construction.

- » Expand the system from a single to a dual module or from dual to triple module without changes to main pipe sizes that are already installed.
- » Help reduce initial capital and design complexity compared to systems that do not offer phased installation.
- » Optimize piping design, branch selector boxes, and indoor units per phase of installation.
- » Synergize well with *Flex Branch Selector* box to allow additional branch selectors to be added in series without having to branch off from main refrigerant pipe

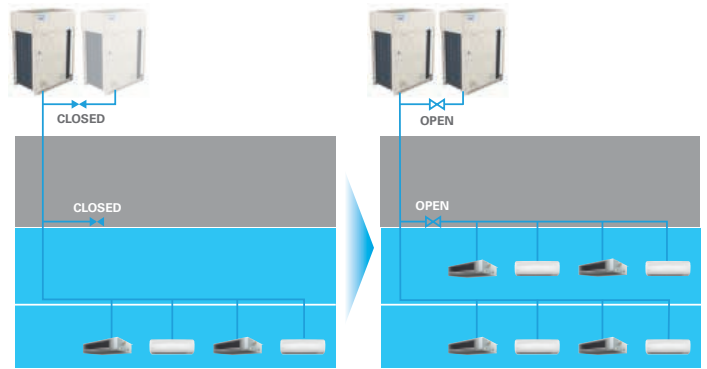

## Enhance phased installation with *Flex Branch Selector* Box series connections.

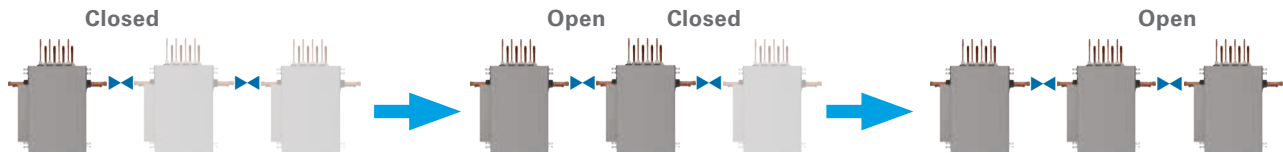

### Adaptive and learning VRT

The new VRV EMERION system features a newly enhanced learning VRT technology. The new learning VRT technology, in addition to helping with annual energy efficiency and maintaining comfort, provides features that enable time-based learning to adjust cooling and heating capacities to provide a stable capacity to the indoor units. The feature must be activated through field setting changes.

### How is energy reduced?

A standard variable refrigerant flow system and previous Daikin VRV systems utilize a capacity based control logic where the system will adjust to meet the capacity requirements of the space. With VRT, Daikin has optimized focus not only on capacity but also on efficiency and comfort.

According to changes in the room's heat load and the ambient air temperature, the evaporating temperature (in cooling) and

condensing temperature (in heating) are automatically adjusted to minimize the difference with the condensing temperature and the evaporation temperature, respectively.

This makes the compressors work less and also enables the system to always maintain the ideal compressor speed so that the Daikin VRV system can deliver the optimum efficiency.

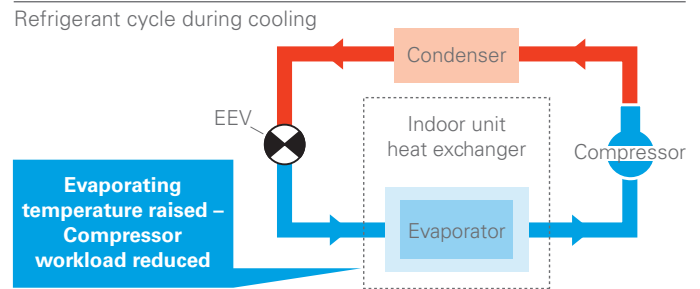

Fine control to match user preference available through mode selection

Basic mode is selected to maintain optimal comfort. VRT is selected to save energy and prevent excessive cooling.

#### Capacity priority

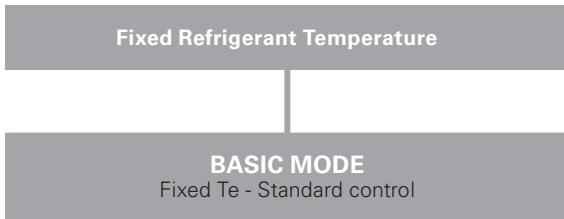

#### Energy saving priority

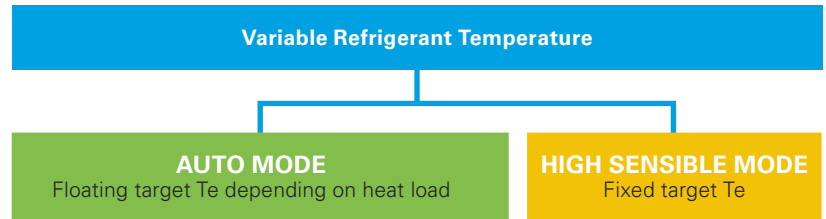

Selecting VRT enables operation to be optimised for either energy efficiency or rapid cooling.

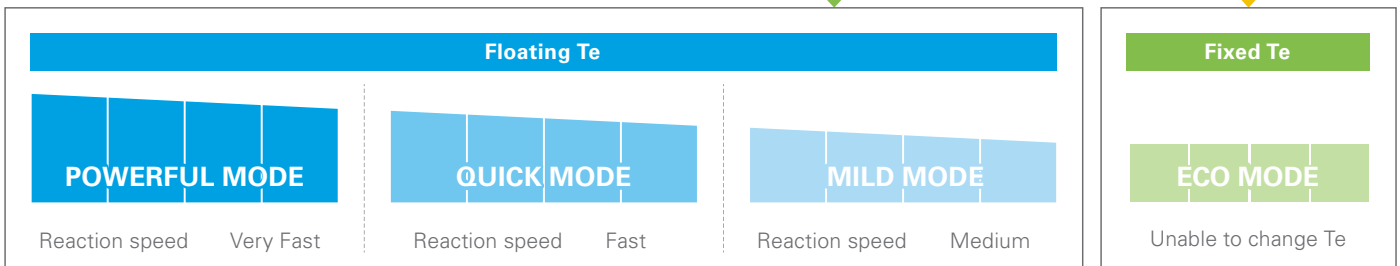

- » Can boost capacity above 100% if needed. The refrigerant temperature can go lower in cooling than the set minimum.
- » Gives priority to very fast reaction speed. The refrigerant temperature goes down fast to keep the room setpoint stable.

- » Gives priority to fast reaction speed. The refrigerant temperature goes down fast to keep the room setpoint stable.

- » Gives priority to efficiency. The refrigerant temperature goes down gradually giving priority to the efficiency of the system instead of the reaction speed.

## Continuous heating during defrost\*

- » Each outdoor unit heat exchanger goes into defrost mode at different times so continuous heating is maintained — avoiding discomfort indoors.
- » Reduces cold drafts.
- » No extra energy for reheating indoors, piping & zone (compared to variable refrigerant flow systems without continuous heating during defrost).

\*Refer to engineering and installation manuals for application rules.

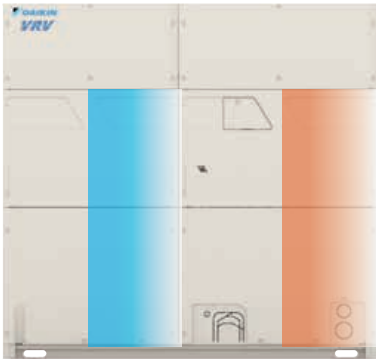

**SINGLE MODULE (16 - 20 T)  
CONTINUOUS HEATING DURING DEFROST**

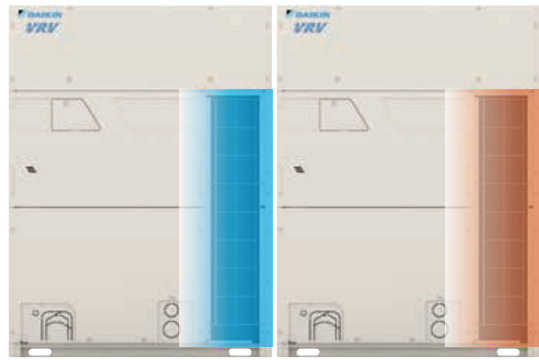

**DUAL MODULE (22 - 40 T)  
CONTINUOUS HEATING DURING DEFROST**

## Hot Gas Defrost Technology

The Hot Gas Defrost circuit at the bottom of the heat exchanger eliminates the need for a base pan heater. This unique technology helps improve defrost, condensate disposal, and reduce ice accumulation at the bottom of the coil. This allows for reliable and efficient system operation year-round.



### Inverter Board Cooled by Refrigerant Circuit.

Minimum influence on electronics from ambient temperature. Section of the coil in the unit is permanently set as condenser for cooling of the inverter board.



### Extended Operation Range — Heating operation down to -22°F\* outdoor temperature and cooling operation down to -4°F\*

Daikin VRV systems can provide heating inside the building even when the outside air temperature is as low as -22°F\* as standard. This enables enhanced application flexibility and use of the system in colder regions.

\*varies based on outdoor unit type

Temperature Limits  
VRV Air-Cooled

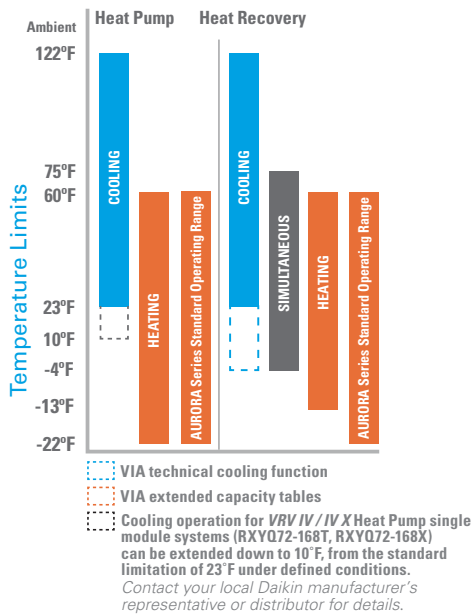

VRV T-Series Water-Cooled

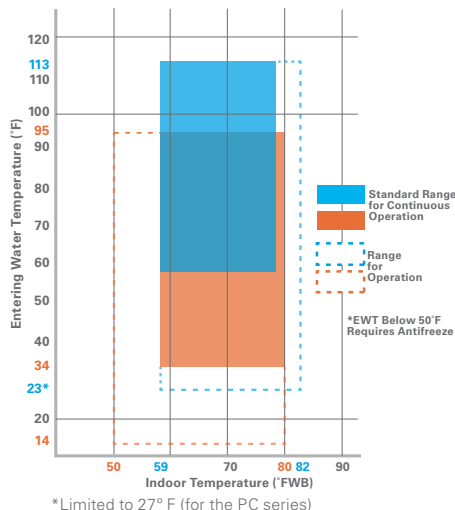

### Piping flexibility — More options for installation location

Daikin VRV provides very flexible piping possibilities. These generous allowances outlined in the figure facilitate an extensive variety of system designs.

- » 100 ft. maximum vertical difference between indoor units provides greater flexibility for riser type piping layouts.
- » Allows for up to 30\* floors to be served from a single VRV System
- » Ideal for mid- to high-rise chiller or WSHP replacement projects

\*varies based on outdoor unit type

Refrigerant Piping Limitations

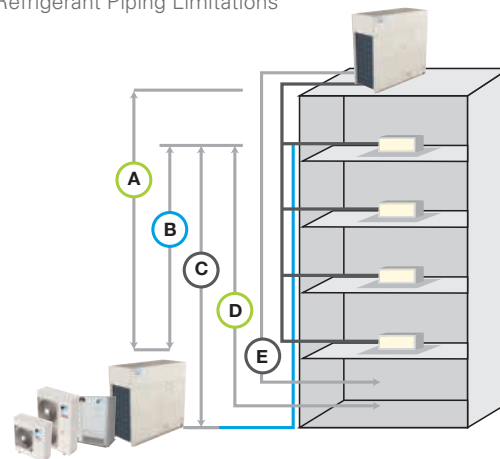

PIPING LIMITATIONS Liquid Line Max (ft)	VRV EMERION Heat Pump & Heat Recovery	AIR-COOLED					WATER-COOLED VRV T-Series
		VRV IV / X Heat Pump	VRV IV / X Heat Recovery	VRV AURORA Low Ambient	VRV S (2 & 3 Ton)	VRV S (4 & 5 Ton)	
A Vertical Drop	164 (361) <sup>1</sup>	164 (295) <sup>1</sup>	164 (295) <sup>1</sup>	164 (295) <sup>1</sup>	98	98	164
B Between IDU	100	100	100 (49) <sup>3</sup>	100 (49) <sup>3</sup>	33	49	98
C Vertical Rise	130 (361) <sup>1</sup>	130 (295) <sup>1</sup>	130 (195) <sup>1</sup>	130 (295) <sup>1</sup>	98	98	130
D From 1st Joint	130 (295) <sup>2</sup>	130 (295) <sup>2</sup>	130 (295) <sup>2</sup>	130 (295) <sup>2</sup>	130	130	130 (295) <sup>2</sup>
E Linear Length	540	540	540	540	164	2-4 230	5 394
Total Network	3280	3280	3280	1640	820	984	980

<sup>1</sup> Setting adjustment on condensing unit required.

<sup>2</sup> Application rules apply. Refer to Installation Manual for further details.

<sup>3</sup> Possible refrigerant noise can be mitigated (via setting adjustments on ODU) when linear length exceeds 390 ft.



## Improved connection ratio flexibility

To properly match outdoor units with indoor units, *VRV* system designers calculate the connection ratio.

If a system has more combined indoor unit capacity index than combined outdoor unit capacity index, the result is a combination ratio that is greater than 100%. If the outdoor unit combined capacity index is higher than the index for indoor units, the combination ratio is less than 100%.

Most Variable refrigerant flow system systems do not allow the combination ratio to be more than 130%. However, due to the advanced design of the Daikin *VRV EMERION* system, the connection ratio is in most cases allowed to be up to 200%.

This generous connection ratio range enables increased flexibility when a *VRV* system is designed.

Connection ratio 50%–200%\*

$$\text{Connection ratio} = \frac{\text{Total capacity index of the indoor units}}{\text{Total capacity index of the outdoor units}}$$

### *VRV EMERION* Connection Ratio

APPLICABLE <i>VRV</i> INDOOR UNITS	FXDQ, FXSQ05-54T, FXMQ_T, FXAQ		OTHER <i>VRV</i> /INDOOR UNIT MODELS	FXFQ07A, FXFQ09A, FXSQ05T, FXZQ05T
6-14 Ton			200%	180%
16-20 Ton		200%	180%	180%
22-40 Ton			160%	160%

\* Connection ratio limitations vary based on outdoor unit and indoor unit models



### Advantages of 3-pipe technology

Daikin 3 pipe technology used in heat recovery systems has dedicated refrigerant pipes for suction gas, liquid and discharge gas. The dedicated refrigerant pipes provide smooth and efficient refrigerant flow during all main modes of operation and aid with the heating performance of the system.

In a 2 pipe heat recovery system, where the gas and liquid travel as a mixture in the refrigerant pipes, the condensing temperature needs to be higher in order to separate the mixed gas and refrigerant. The higher condensing temperature that is needed means that the compressor has to work harder. In addition, the disturbed refrigerant flow in large pipes on 2 pipe system results in extra pressure drop which can negatively impact the system capacity and efficiency.

### New Flex Branch Selector for Ultimate Flexibility

Daikin's new *Flex Branch Selector* boxes are engineered to be compact and provide flexibility in design, installation, maintenance, and service. Packed with Daikin's state of the art technology, the new *Flex Branch Selector* boxes fit in tight mechanical spaces (common in ceilings) combined with flexibility in piping configuration and movable E-box makes the new design an ideal choice for commercial buildings.



### Main Features and Benefits

#### Flexible

- » Design flexibility with versatile piping configurations of Left or Right or Pass through layouts.
- » Engineered for tight ceiling spaces with a compact height of 9½" and 0"¹ service clearance between the slab and the top of the *Flex Branch Selector* box.
- » Flexibility to expand design with up to 121 ports and 230Mbh¹ down stream capacity by connecting multiple boxes in series.
- » Ability to optimize installed system cost by reducing *REFNETs* and braze joints in pass thru configuration vs non-pass through configuration.
- » Simple electrical configurations with flexibility to re-position E-box.²
- » Ability to mix and match Daikin *Flex Branch Selector* boxes and standard branch selector box for ultimate design flexibility.

¹ Refer to engineering manuals for design rules

² Feature available for BSF4Q54TAVJU (4-port) model only

#### Installation Flexibility

- » Ease of maintenance with access to electronic expansion valve (EEV) heads and motor via side access panel.
- » Eliminate cross piping with refrigerant pipe identification labels.
- » Simple electrical and communication wiring with connection from the front side of E-box.²

#### Innovative

- » Daikin's high specification EEV enables precise refrigerant control for high comfort in user spaces and reliable system operation.
- » Hermetically sealed to prevent condensate build up within the unit, eliminating the need for a condensate drain pan and plumbing connections for a simple installation.
- » Low ambient cooling down to -4°F¹ for simple and integrated system design.

Engineered to create a truly unique experience for contractors, VRV EMERION offers a new and improved design to provide ease of service and maintenance making way for simplicity in installation.

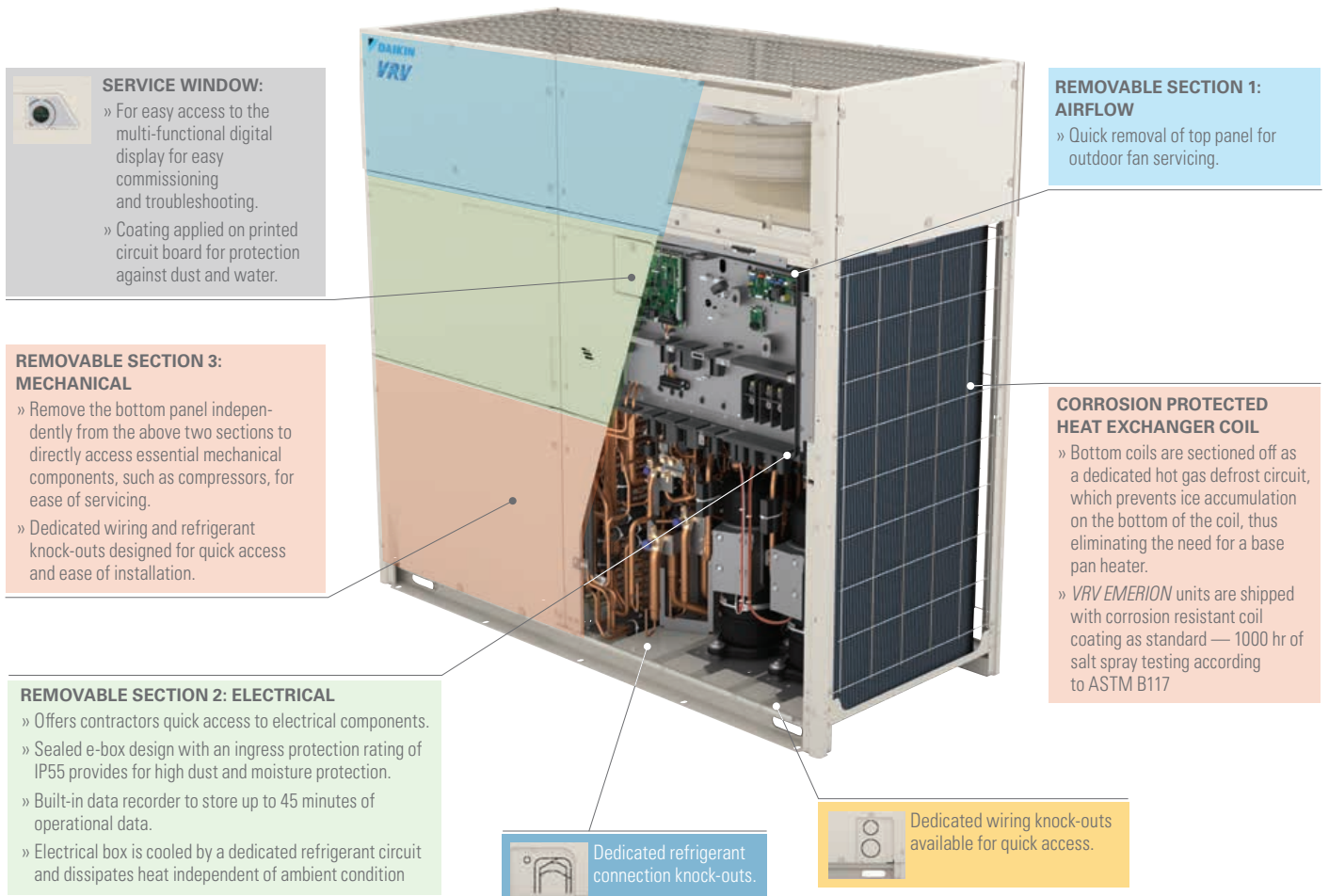

**SERVICE WINDOW:**

- » For easy access to the multi-functional digital display for easy commissioning and troubleshooting.
- » Coating applied on printed circuit board for protection against dust and water.

**REMOVABLE SECTION 1: AIRFLOW**

- » Quick removal of top panel for outdoor fan servicing.

**REMOVABLE SECTION 3: MECHANICAL**

- » Remove the bottom panel independently from the above two sections to directly access essential mechanical components, such as compressors, for ease of servicing.
- » Dedicated wiring and refrigerant knock-outs designed for quick access and ease of installation.

**CORROSION PROTECTED HEAT EXCHANGER COIL**

- » Bottom coils are sectioned off as a dedicated hot gas defrost circuit, which prevents ice accumulation on the bottom of the coil, thus eliminating the need for a base pan heater.
- » VRV EMERION units are shipped with corrosion resistant coil coating as standard — 1000 hr of salt spray testing according to ASTM B117

**REMOVABLE SECTION 2: ELECTRICAL**

- » Offers contractors quick access to electrical components.
- » Sealed e-box design with an ingress protection rating of IP55 provides for high dust and moisture protection.
- » Built-in data recorder to store up to 45 minutes of operational data.
- » Electrical box is cooled by a dedicated refrigerant circuit and dissipates heat independent of ambient condition

**Dedicated refrigerant connection knock-outs.**

**Dedicated wiring knock-outs available for quick access.**

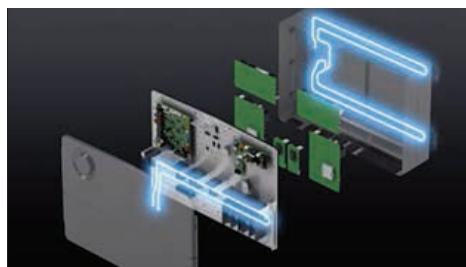

**NEW P-TYPE COMPRESSOR**



- » Compressor technology with spiral design and injection valves for precise refrigerant control.
- » Strong and efficient motors for optimized compressor performance and part load efficiencies.
- » Back pressure control mechanism optimizes the internal compressor pressure with the intermediate pressure adjusting port according to operating conditions. This stabilizes the orbiting scroll, reducing leaks and scroll friction during operation (compared to compressors without back pressure control).

### Outdoor unit sequencing technology

#### Automatic sequencing operation

During start-up, Daikin VRV unit sequencing operation will be automatically enabled to ensure balanced operation of each outdoor unit to improve longevity of equipment and stable operation.

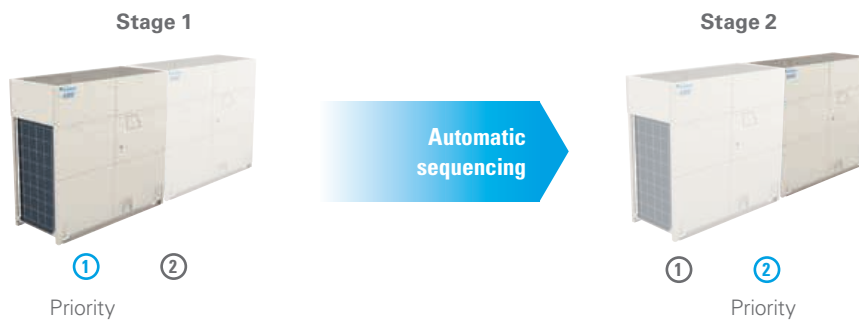

### Double backup operation functions responding resiliently to various unexpected situations

#### Double backup operation functions

Daikin VRV system boasts double backup operation functions, which can secure the use of air conditioners in this area to the greatest extent by emergently enabling double backup operation functions even if failure occurs in a set of air conditioning equipment. In the event of a failure, emergency operation can be conveniently enabled to allow the remaining system to operate in a limited fashion.

#### Unit backup operation function

If malfunction occurs in an outdoor unit...

Emergency operation can be conveniently set and enabled by the remote controller for indoor unit (for systems composed of two or more outdoor units).



#### Compressor backup operation function\*

If malfunction occurs in a compressor...

Emergency operation can be easily set and enabled by the outdoor unit.

\* Only for modules with 2 compressors

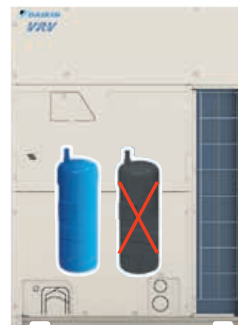

With the *VRV* heat pump and heat recovery systems, the Daikin brand is one of the most extensive lines of heating and cooling systems in North America.



## Daikin VRV

Setting the Standards, Again (cont.)

### VRV outdoor units assembled in the U.S.A.

The VRV IV is the first variable refrigerant flow system to be Designed, engineered, and assembled in North America. With a state of the art production line, local/in house preparation, tooling, processing and construction of heat exchangers, refrigerant

cycle assemblies, sheet metal parts, electrical box, etc., we can react quickly to changes in the market-place and truly optimize the product for the North American market.

- » Extensive local inventory and short lead times.
- » Typically, 98% of replacement parts can be shipped in approximately 48 hours.



## VRV system configuration and commissioning

- » The VRV configurator is an advanced software solution that allows for easy system configuration and commissioning.
- » Less time is required on the roof configuring the outdoor unit.
- » Multiple systems at different sites can be managed in exactly the same way, thus offering simplified commissioning for key accounts.
- » Initial settings on the outdoor unit can be easily retrieved.



Simplified commissioning

Retrieve initial system settings



## Outstanding 10-Year Parts and Compressor Warranties\*



Outstanding commercial warranty\* with 10-Year Replacement Compressor Warranty and 10-Year Parts Warranty as standard ensures our confidence in our new VRV IV X.

\* Complete warranty details available from your local Daikin manufacturer's representative or distributor or online at [www.daikincomfort.com](http://www.daikincomfort.com).

# Daikin VRV

## What does a VRV installation mean to you?

### Consulting engineers

Daikin's VRV technology maximizes flexibility and leads the way in customization to match individual building requirements in comfort and energy — all designed to reduce the total life cycle costs.

- » Maximum flexibility to meet customer requirements
- » Advanced software tools assist with system design

### Building owners

VRV is the ultimate in customized comfort and intelligent control tailored to your individual needs and used to maximize energy efficiency.

- » Optimized life cycle cost
- » No more cold droughts with variable refrigerant temperature
- » Single point of contact for the design of your climate system
- » Integrated system, combining air conditioning, heating, ventilation, etc., enables optimized system function
- » Multiple systems can be managed in exactly the same way for key accounts
- » Dedicated after-sales service to ensure fast on-site support



See how you can profit from Daikin's flexible and efficient product range.



### Installers

Daikin VRV sets the standard with state-of-the-art technology and time-saving commissioning and servicing.

- » Simplified and time-saving commissioning with VRV configurator
- » Unique range of single and multi Branch Selector boxes reduce installation time compared to previous generation
- » Wide range of outdoor with single module up to 20 Ton and dual module up to 40 Tons
- » One supplier equals one point of contact
- » Maximum flexibility to meet customer requirements
- » Customized training to maximize expertise
- » Service Window allows for easy commissioning and troubleshooting

### Architects

- » Indoor units with a sleek and sophisticated design
- » Space efficient outdoor units
- » Low sound levels for both indoor and outdoor units
- » Wide range of indoor units to allow installation in most environments

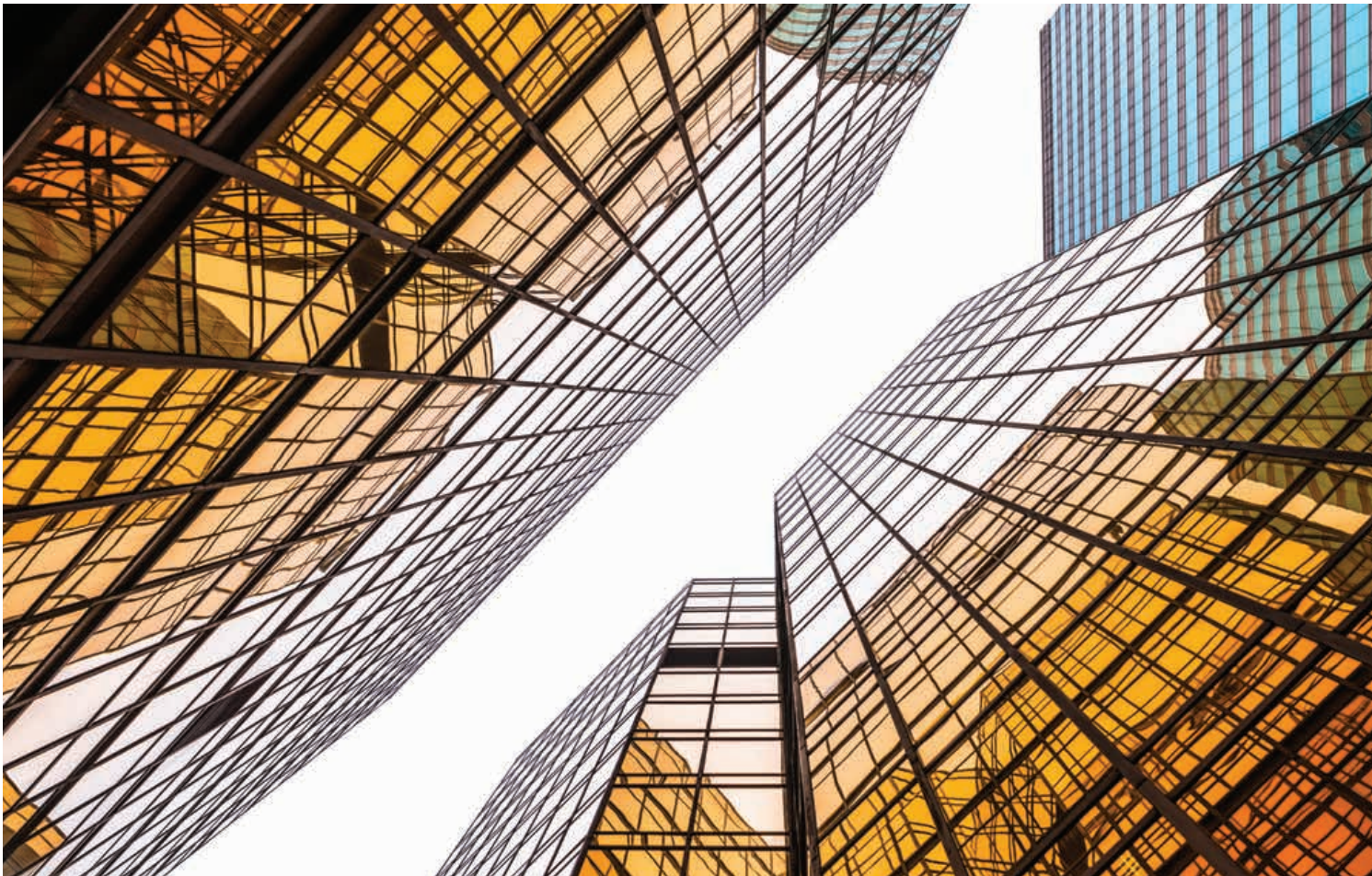

# Daikin VRV

## Vertical Market Applications

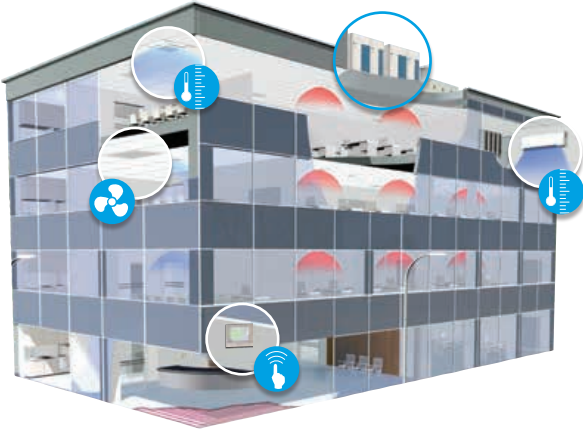

### VRV for offices and banks

#### Our office solution offers:

- » Increased occupant productivity with individual zone control, low sound levels & tight temperature control
- » Optimized energy efficiency
- » Simple maintenance — low operational cost
- » Modular system allowing cost effective out-of-hours operation
- » Integrated ventilation solutions allowing high indoor air quality
- » Complete building management with *intelligent Touch Manager (iTM)* or *HERO Pro Edge*
- » Remote monitoring with email alerts
- » Self-cleaning filters yielding operational and maintenance cost savings
- » Intelligent sensors on *Round Flow* cassette, suspended cassette (optional), and *VISTA 2x2* cassette (optional) maximize efficiency using innovative occupancy sensing features.

### VRV for hotels

#### Our hotel solution offers:

- » Energy efficient systems capable of simultaneous heating and cooling.
- » Ultra-quiet guest room solutions discrete and simple to control.
- » Flexible installation options lowering installation complexity, costs and space requirements than most traditional HVAC systems
- » Inverter technology creating the perfect guest room environment by regulating temperature swings and humidity
- » 24 X 7 remote control and management using *HERO Pro Edge* with improved operational capabilities.
- » Seamless integration & compatibility with industry acclaimed *INNCOM™* systems delivering combined benefits in guest operations and experience for both guests and management team



## VRV for retail and restaurants

Our retail solutions offer:

- » Scalable project opportunities with modular design
- » Individual zone control for advanced zoning capabilities
- » Enhanced efficiency in retail chain operations and energy usage from Daikin's *HERO* Cloud Services.
- » Centralized building control & autonomy from *VRV* remote commissioning and management capability
- » 10-Years Parts and Compressor Warranty\*

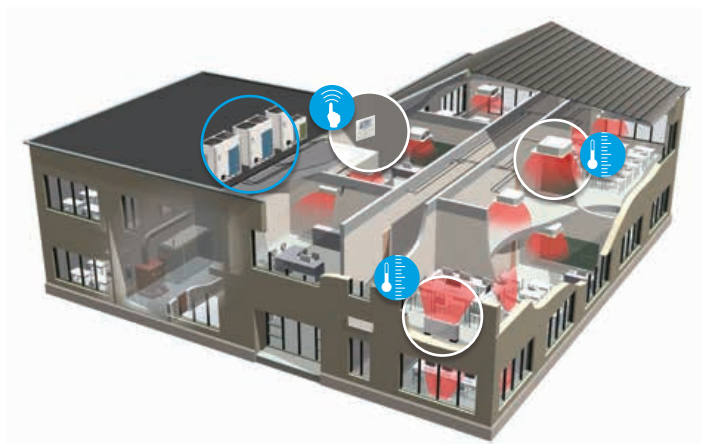

## VRV for schools

Our school solution offers:

- » Flexible, scalable total HVAC solution for school classrooms, common areas and administrative offices
- » Over 12,000 Daikin *VRV* systems in schools in North America
- » Quiet operating sound levels as low as 28 dB(A)
- » Minimal occupant air temperature variations
- » Advanced zoning capabilities with user-friendly and intuitive controls
- » Modular in design accommodating unique school and classroom spaces
- » Self-cleaning filter option for *Round Flow* cassette simplifies maintenance process and increases operational efficiency
- » Combined benefits of energy and operations efficiency for both school administrators and maintenance staff
- » 10-Year Parts and Compressor Warranty\*

\* Complete warranty details available from your local Daikin manufacturer's representative or distributor or online at [www.daikincomfort.com](http://www.daikincomfort.com).



# Product Portfolio



# Product Portfolio

## Outdoor Units



### NEW VRV EMERION R32

#### VRV EMERION R-32 Heat Pump / Heat Recovery

Simple. Sustainable. Connected.

- » New D4-Net provides communication that is faster and carries more data volume when compared to the D3-Net.
- » Reduced install and commission time through auto address feature with D4 communications protocol.
- » R-32 system with lower Global Warming Potential (GWP), provides improved efficiency compared to R-410A and requires lower total system charge.
- » Increased energy savings through new improved VRT technology with evaporation temperature control at each indoor unit (BS or SSOV required).

- » New remote field setting option that allows data retrieval and field setting changes of units in the system from anywhere, without the need for physical access to each room.
- » New field setting that allows reuse of R-410A piping network for new R-32 system, eliminating need to replace piping for retrofit applications.
- » Heating down to -22°F as standard and high heating capacities at 17°F make it an ideal choice for all-electric heat pump solutions
- » Simple and Stylish design with expanded line up with single-module units from 6 – 20 T and dual-modules up to 40 T



### VRV EMERION

#### VRV EMERION Heat Pump / Heat Recovery

Simple. Sustainable. Connected.

- » Simple and Stylish design with expanded line up with single-module units from 6 – 20 T and dual-modules up to 40 T
- » High energy efficiency with IEERs up to 30.0 delivers up to 30% efficiency increase compared to previous VRV systems
- » Sealed e-box design with an ingress protection rating of IP55 provides for high dust and moisture protection
- » Simplified diagnosis with built-in data recorder which stores up to 45 minutes of operational data
- » Engineered for ease of installation and service with three-segment panel design. Design flexibility to enlarge system from single to a dual-module without changes to

- installed main pipe sizes for phased installation or tenant fit-out buildings
- » Heating down to -13°F as standard and high heating capacities at 17°F make it an ideal choice for all-electric heat pump solutions
- » Continuous heating during defrost capability with single module (16 T – 20 T) and all dual module systems. Only available on heat recovery.
- » Hot gas defrost circuit allows for installation without base pan heater.



### VRV IV X

#### VRV IV X Heat Pump / Heat Recovery

Industry's first 3-phase variable refrigerant flow system to integrate with communicating gas furnaces

- » Equipped with Daikin's patented inverter based vapor-injection compressor to provide high heating capacities down to -13°F WB
- » Enhanced design flexibility by allowing for phased installations with predefined pipe sizes and design rules
- » New service window provides ease of access to the multi-functional display without removing the main electrical panel. The built-in multi-functional display is utilized for commissioning and maintenance and quickly



- converts to digital gauges to provide refrigerant pressure and temperatures
- » Choice of gas furnace or heat pump heating for optimizing operational costs based on utility cost
- » Field performable intermittent outdoor fan operation to help minimize snow accumulation on fan blades when the system is in thermal off
- » Total comfort solution for heating, cooling, ventilation, and controls
- » Outstanding warranty\* with 10-Year Compressor and Parts Limited Warranty as standard
- » Fully integrated solution with high efficiency (IEER up to 27.80 on Heat Recovery models and IEER up to 27.30 for Heat Pump)



## VRV S SERIES

### Air-Cooled

The Daikin VRV-S elevates the renowned VRV air-cooled technology with its sleek, compact design tailored for small-scale installations without compromising performance. The Daikin VRV-S comes integrated with Variable Refrigerant Temperature (VRT) technology that supports optimal comfort throughout the year while maintaining overall energy efficiency.



R32

- » Addition of a 2-ton model for a complete 2- to 5-ton offering
- » Long pipe lengths with vertical separation up to 164 ft. and total pipe length up to 984 ft.
- » Compact, space-saving single fan chassis design across all sizes
- » Dependable operation in extreme ambient conditions of up to 122°F<sup>1</sup>
- » Compact height of only 34-1/4" to support a range of applications
- » Efficient operation and year-round energy savings through
- » Smart Variable Refrigerant Temperature (VRT) technology improved efficiencies in heating and cooling operation compared to the previous R-410A lineup
- » Quiet operation with sound levels as low as 56 dB(A)
- » Ease of retrofit of existing R-410A installation with the ability to re-use larger diameter refrigerant pipes via field setting
- » Optional base pan heater to defrost base pan in cooler climate applications
- » Increased nominal capacity compared to previous
- » R-32 lineup up to 60,000 Btu/hr for the 5T mode

## VRV

### VRV T-Series Water-Cooled Condensing Unit Heat Pump / Heat Recovery

- » Flexible System design with increased diversity up to 150%<sup>†</sup>
- » Can be applied to both geothermal and boiler/tower applications as standard with condenser water inlet temperature as low as 14°F<sup>†</sup> in heating and 23°F<sup>†</sup> in cooling is possible
- » Triple-stack capable to deliver up to 36 tons in just under 11.5 feet ceiling height thanks to the compact design
- » Engineered with heat rejection cancellation technology<sup>†</sup> to eliminate mechanical room conditioning requirements
- » 2-9V variable water flow control logic<sup>†</sup> as standard to increase waterside system operational efficiencies
- » Drop-down switch box for easy service to key components
- » Field selectable top or front refrigerant connections for flexible and easy installation



<sup>1</sup> Multi module heat recovery systems only for continuous heating during defrost  
<sup>†</sup> Conditions/rules apply. Refer to Installation and Engineering Manual for further details.  
<sup>\*</sup> Complete warranty details available from your local Daikin manufacturer's representative or distributor or online at [www.daikincomfort.com](http://www.daikincomfort.com).  
<sup>\*\*</sup> Varies based on condensing unit model selected

## VRV

### VRV AURORA Heat Pump / Heat Recovery



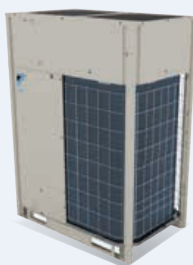







- » Variable refrigerant flow system Industry's first air-cooled system that delivers heating down to -22°F (-30°C) as standard
- » Hot gas base pan circuit allows installation without an additional drain pan heater
- » Designed to provide continuous heating during defrost and oil return<sup>1</sup>
- » Engineered with Daikin vapor injection compressor for optimized part load efficiencies



# Product Portfolio

## Outdoor Units (cont.)









TYPE	MODEL	FEATURES	PRODUCT NAME	CAPACITY (TONS)																							
				3	4	5	6	8	10	12	14	16	18	20	22	24	26	28	30	32	34	36	38	40			
Air-Cooled	NEW VRV EMERION Heat Pump & Heat Recovery	<b>R-32</b> » New improved D4 net provides faster communication speeds and larger data volume compared to D3 net, up to 30 times the amount of data compared to D3 net. » Reduced install and commission time through auto address feature with D4 communications protocol. » R-32 system with lower Global Warming Potential (GWP), provides improved efficiency compared to R410A and requires lower total system charge. » Increased energy savings through new improved VRT technology with evaporation temperature control at each indoor unit (BS or SSOV required). » New remote field setting option that allows data retrieval and field setting changes of units in the system from anywhere, without the need for physical access to each room. » New field setting that allows reuse of R410A piping network for new R-32 system, eliminating need to replace piping for retrofit applications. » Heating down to -22°F as standard and high heating capacities at 17°F make it an ideal choice for all-electric heat pump solutions » Simple and Stylish design with expanded line up with single-module units from 6 – 20 T and dual-modules up to 40 T	RXYA_A, REYA_A <b>R32</b>  				■																				
							■	■	■	■																	
														■	■	■											
																		■	■	■	■						
																									■		
																									■	■	■
	VRV/IV X Heat Pump & Heat Recovery		» Industry's first 3-phase variable refrigerant flow system to integrate with communicating gas furnaces » Enhanced design flexibility by allowing for phased installations with predefined pipe sizes and design rules » VRV/IV X service window provides ease of access to the multi-functional display without removing the main electrical panel. The built-in multi-functional display is utilized for commissioning and maintenance and quickly converts to digital gauges to provide refrigerant pressure and temperatures.	RXYQ_X, REYQ_X  				■	■	■	■	■															
																		■	■	■	■	■	■				
																										■	■

\*\* 6-ton model is a PC-Series model. Some features may not be available for this model. \*\*\* Conditions/rules apply. Refer to Installation and Engineering Manual for further details.











TYPE	MODEL	FEATURES	PRODUCT NAME	CAPACITY (TONS)																													
				3	4	5	6	8	10	12	14	16	18	20	22	24	26	28	30	32	34	36	38	40									
Air-Cooled	NEW VRV EMERION Heat Pump & Heat Recovery	<b>R-410A</b> » New Simple and Stylish design with expanded line up with single-module units from 6 – 20 T and dual-modules up to 40 T. » High energy efficiency with IEEs up to 30.0 delivers up to 30% efficiency increase compared to previous VRV systems » Sealed e-box design with an ingress protection rating of IP55 provides for high dust and moisture protection. » Simplified diagnosis with built-in data recorder which stores up to 45 minutes of operational data. » Engineered for ease of installation and service with three-segment panel design. » Heating down to -13°F as standard and high heating capacities at 17°F make it an ideal choice for all-electric heat pump solutions » Continuous heating during defrost capability with single module (16 T – 20 T) and all dual module systems. Only available on Heat Recovery » Hot gas defrost circuit allows for installation without base pan heater.	RXYQ_A, REYQ_A  				■																										
								■	■	■	■																						
															■	■	■																
																				■	■	■	■										
																													■				
																													■	■	■	■	■

\*\* 6-ton model is a PC-Series model. Some features may not be available for this model. \*\*\* Conditions/rules apply. Refer to Installation and Engineering Manual for further details.

# Product Portfolio

## Outdoor Units (cont.)

TYPE	MODEL	FEATURES	PRODUCT NAME	CAPACITY (TONS)																						
				2	3	4	5	6	8	10	12	14	16	18	20	22	24	26	28	30	32	34	36	38	40	
Air-Cooled	VRV AURORA Heat Pump & Heat Recovery	<ul style="list-style-type: none"> <li>» Variable refrigerant flow system Industry's first air-cooled system that delivers heating down to -22°F (-30°C) as standard</li> <li>» Hot gas base pan circuit allows installation without an additional drain pan heater</li> <li>» Designed to provide continuous heating during defrost and oil return<sup>1</sup></li> <li>» Engineered with Daikin vapor injection compressor for optimized part load efficiencies</li> </ul> <p><sup>1</sup> Multi module heat recovery systems only for continuous heating during defrost</p>	RXLQ_T, RELO_T <b>VRV</b> 																							
																										
	VRV S-series (R-32) Heat Pump	<ul style="list-style-type: none"> <li>» Single phase technology</li> <li>» Space saving solution without compromising on efficiency</li> <li>» For residential and light commercial applications</li> </ul>	RXTA_AA R32 <b>VRV S SERIES</b> 																							
Water-Cooled	VRV T-Series Water-Cooled Condensing Unit Heat Recovery & Heat Pump	<ul style="list-style-type: none"> <li>» Ideal for high rise buildings, using water as heat source</li> <li>» Enables use of geothermal energy as a renewable energy source</li> <li>» Flexible System design with increased diversity up to 150%***</li> <li>» Triple-stack capable to deliver up to 36 tons in just under 11.5 feet ceiling height thanks to the compact design</li> <li>» Engineered with heat rejection cancellation technology*** to eliminate mechanical room conditioning requirements</li> <li>» 2-9V variable water flow control logic*** as standard to increase waterside system operational efficiencies</li> </ul>	RWEO_T <b>VRV</b> 																							
																										
																										

\*\* 6-ton model is a PC-Series model. Some features may not be available for this model. \*\*\* Conditions/rules apply. Refer to Installation and Engineering Manual for further details.



# Product Portfolio

## Indoor Units



TYPE	MODEL	FEATURES	PRODUCT NAME	
Ducted	HSP DC Concealed Ducted Unit	<ul style="list-style-type: none"> <li>» Energy efficient due to the DC fan motor</li> <li>» Ideal to use together with the optional Daikin Zoning Kit, DZK</li> <li>» Enhanced indoor air quality and LEED® ready with MERV 13 filter options</li> <li>» Flexible ductwork design with ESP capabilities up to 0.8" In. Wg</li> <li>» Low profile height of only 9-11/16"</li> </ul>	<p><b>(R-32)</b></p> <ul style="list-style-type: none"> <li>» Factory-installed integrated refrigerant leak sensor</li> <li>» Dispersion Mode: Higher airflow rate for leak mitigation through circulation</li> <li>» On-board terminal for connection to external alarms and monitoring systems</li> </ul>	FXMQ_TBVCJU (R-410A) FXMA_AAVJU <b>(R-32)</b> 
	MSP Concealed Ducted Unit	<ul style="list-style-type: none"> <li>» Powerful static pressure up to 0.6" In. Wg</li> <li>» Low profile height of only 9-11/16"</li> <li>» Auto fan speed control optimizes energy use, occupant comfort, and sound levels</li> <li>» Factory shipped for rear air inlet – field convertible to bottom air inlet</li> <li>» Integral condensate pump with more than 25" of lift</li> </ul>	<p><b>(R-32)</b></p> <ul style="list-style-type: none"> <li>» Factory-installed integrated refrigerant leak sensor</li> <li>» Dispersion Mode: Higher airflow rate for leak mitigation through circulation</li> <li>» On-board terminal for connection to external alarms and monitoring systems</li> </ul>	FXSQ_TBVCJU (R-410A) FXSA_AAVJU <b>(R-32)</b> 
	LSP Slim Concealed Ducted Unit	<ul style="list-style-type: none"> <li>» Slim height, at only 7- 7/8"</li> <li>» Washable filter included</li> <li>» Low sound level</li> <li>» Factory shipped for rear air inlet —field convertible to bottom air inlet</li> <li>» Condensate pump with vertical lift of up to 21-5/8" included as standard</li> </ul>	<p><b>(R-32)</b></p> <ul style="list-style-type: none"> <li>» Factory-installed integrated refrigerant leak sensor</li> <li>» Dispersion Mode: Higher airflow rate for leak mitigation through circulation</li> <li>» On-board terminal for connection to external alarms and monitoring systems</li> </ul>	FXDQ_MVJU 
	Multi-Position Air Handling Unit	<ul style="list-style-type: none"> <li>» Ideal replacement for fan coils, geothermal heat pumps or traditional splits systems</li> <li>» Upflow and horizontal right installation is permitted</li> <li>» ECM fan motor provides energy efficiency</li> <li>» Wide line up of electric heat (field installed) options from 3kW to 20kW</li> </ul>		FXTQ_TAVJU (R-410A) FXTA_AAVJU <b>(R-32)</b> 
	HSP High Capacity Concealed Ducted Unit	<ul style="list-style-type: none"> <li>» Powerful static pressure capability, with up to 1.0 in.w.g. (249Pa) external static pressure.</li> <li>» Ease of installation with remotely adjustable external static pressure using a Navigation Remote Controller (BRC1NRV71/72).</li> <li>» Designed for easier servicing and maintenance (compared to previous model) with 2 removable service panels for inspection of the interior or drain pan.</li> <li>» Sound levels as low as 28 dB(A) for quiet operation.</li> <li>» Includes a standard 1" filter rack for faster installation in the field, filter to be field provided</li> </ul>		FXMQ_MVJU 
Duct-Free	Low Temperature (LT) Hydrobox	<ul style="list-style-type: none"> <li>» High-efficiency all-electric heat pump hot and chilled water solution for VRF</li> <li>» Direct control over the leaving water temperature for a wide leaving water temperature range down to 50°F in cooling and up to 113°F in heating</li> <li>» Ships with factory-installed hydronic accessories</li> </ul>		HXY48TAVJU 
	Round Flow Sensing Cassette	 <ul style="list-style-type: none"> <li>» True 360° Airflow and three room sensors enables optimized occupant comfort</li> <li>» Energy efficient with DC fan motor and auto-logic that adjusts fan speed</li> <li>» Optional self-cleaning filter panel to further increase efficiency and reduce maintenance</li> <li>» Increased indoor air quality with high efficiency filter options and ventilation connection kit</li> <li>» Very flexible with 18 different possible airflow patterns</li> </ul>	<p><b>(R-32)</b></p> <ul style="list-style-type: none"> <li>» Factory-installed integrated refrigerant leak sensor</li> <li>» Dispersion Mode: Higher airflow rate for leak mitigation through circulation</li> <li>» On-board terminal for connection to external alarms and monitoring systems</li> </ul>	FXFQ_TVJU (R-410A) FXFA_AAVJU <b>(R-32)</b> 
	4-Way Ceiling-Suspended Cassette	<ul style="list-style-type: none"> <li>» Very low unit height of under 8"</li> <li>» Optional Sensor Kit enables input from three room sensors</li> <li>» Stylish unit blends easily with any interior</li> <li>» Individual air louver control</li> </ul>		FXUQ 
	VISTA 2x2 Cassette for VRF Systems	<ul style="list-style-type: none"> <li>» Fits in a standard 2' x 2' ceiling grid with no overlap of adjacent tiles</li> <li>» Features a low profile decoration panel design measuring only 5/16" deep</li> <li>» Space-saving depth of units requires only 11.75" of ceiling space</li> <li>» Easy-to-clean grille, washable long-life filter</li> <li>» Optional space and presence sensor accessory enhances energy efficiency and occupant comfort</li> </ul>	<p><b>(R-32)</b></p> <ul style="list-style-type: none"> <li>» 4-way, 3-way, and 2-way blow configurability</li> <li>» Independently motorized louver outlets</li> <li>» High efficiency DC fan motor with Auto fan speed control</li> <li>» Independently configurable auxiliary heat on/off temperatures</li> <li>» Direct outside air integration possible</li> </ul>	FXZQ_TBVCJU FXZA_AAVJU <b>(R-32)</b> 
	Ceiling-Mounted Cassette (Single flow)	<ul style="list-style-type: none"> <li>» Only 7- 7/8" in height and a width of 18-1/2" making it possible to use this style of indoor unit in the tightest of spaces</li> <li>» The unit is equipped with both horizontal and vertical louvers to optimize the airflow and throw to suite your room design</li> <li>» The indoor unit can be set to 5 predetermined fan speeds which allows for optimum and comfortable airflow</li> <li>» Factory installed condensate pump with a lift capacity of up to 33- 7/8" (measured from the bottom of the unit)</li> </ul>		FXEQ_PVJU 
	Ceiling-Suspended Unit	<ul style="list-style-type: none"> <li>» One of our slimmest indoor units, less than 8"</li> <li>» Wide air discharge outlet distributes a comfortable airflow throughout the entire space</li> <li>» Innovative stream fan technology keeps sound pressure levels low</li> <li>» Smooth flat louver design makes cleaning simple</li> <li>» Long-life filter is standard</li> </ul>		FXHQ_MVJU 
	Wall-Mounted Unit	<ul style="list-style-type: none"> <li>» Auto-swing mechanism ensures efficient air distribution via louvers</li> <li>» Wide air discharge outlet distributes a comfortable airflow throughout the entire space</li> <li>» Horizontal louvers and front panel can be easily removed for cleaning</li> <li>» Drain pipe can be easily hidden from sight</li> <li>» Compact and stylish design</li> </ul>	<p><b>(R-32)</b></p> <ul style="list-style-type: none"> <li>» Expanded lineup with the addition of the 5,400 Btuh size unit</li> <li>» Up-down and left-right airflow direction control</li> <li>» Efficient operation and year-round energy savings through Smart Variable Refrigerant Temperature (VRT) technology</li> <li>» New D4 communication protocol which unlocks remote access to units through Daikin Hero .</li> </ul>	FXAQ_PVJU FXAA_AAVJU <b>(R-32)</b> 
	Floor-Standing Unit	<ul style="list-style-type: none"> <li>» Ideal for installation beneath a window</li> <li>» Unit requires minimal installation space</li> <li>» Fitted with a washable long-life filter</li> <li>» Remote-control options available</li> <li>» Space-saving unit can be freestanding or wall-mounted</li> </ul>		FXLQ_MVJU9, FXNQ_MVJU9 



	CAPACITY															
	MBH	5.8	7.5	9.5	12	15	18	24	30	36	42	48	54	60	72	96
	TON	0.5	0.6	0.75	1	1.25	1.5	2	2.5	3	3.5	4	4.5	5	6	8
						■	■	■	■	■		■	■			
	■	■	■	■	■	■	■	■	■	■		■	■			
		■	■	■			■	■								
				■		■	■	■	■	■	■	■	■	■		
												■			■	■
												■				
		■	■	■	■	■	■	■	■	■		■				
			■	■	■	■	■	■								
					■			■		■						
			■	■	■		■	■								
		■	■	■		■	■									









# Product Portfolio

## Accessories



### Branch Selector Boxes

Providing flexibility and minimizing mechanical and electrical installation costs, Daikin's branch selector boxes that are used in Heat Recovery systems, are ideal for spaces that require individual heating and cooling control.

SINGLE-PORT BRANCH SELECTOR			MULTI-PORT BRANCH SELECTOR										
													
<b>MODELS</b>	BSQ36TVJ	BSQ60TVJ	BSQ96TVJ	BS4Q54TVJ	BSF4Q54TVJ	BSF6Q54TVJ	BSF8Q54TVJ	BS10Q54TVJ	BS12Q54TVJ				
<b>PORTS</b>	1			4		6		8		10		12	

### REFNET

REFNET joints distribute correct flow of refrigerant in every branch of the piping network. Sourced locally and complies to ASTM E-84 Class A low flame and smoke spread index requirements.



REFNET Joint



REFNET Header

### VRV IV X, VRV IV / VRV AURORA Heat Pump

OPTIONAL ACCESSORIES		RXYQ72 - 96T RXYQ72 - 96X RXLQ72 - 96T	RXYQ120-168T RXYQ120-168X RXLQ120T	RXYQ192-336T RXYQ192-336X RXLQ144-240T	RXYQ360-408T RXYQ360-408X RXYQ360-480MBH
Distributed piping	REFNET Header	KHRP26M22H (max. 4 branch) KHRP26M33H (max. 8 branch)	KHRP26M22H (max. 4 branch) KHRP26M33H (max. 8 branch) KHRP26M72H (max. 8 branch)	KHRP26M22H (max. 4 branch) KHRP26M33H (max. 8 branch) KHRP26M72H (max. 8 branch)	KHRP26M22H (max. 4 branch) KHRP26M33H (max. 8 branch) KHRP26M72H (max. 8 branch) KHRP26M73HU (max. 8 branch)
	REFNET Joint	KHRP26A22T, KHRP26A33T	KHRP26A22T, KHRP26A33T, KHRP26M72TU	KHRP26A22T, KHRP26A33T, KHRP26M72TU, KHRP26M73TU	KHRP26A22T, KHRP26A33T, KHRP26M72TU, KHRP26M73TU
Outdoor unit multi connection piping kit		—		BHFP22P100U	BHFP22P151U

### VRV EMERION / VRV IV X / VRV IV / VRV AURORA Heat Recovery

OPTIONAL ACCESSORIES		RXYQ72-96A REYQ72 - 96A REYQ72 - 96X RELQ72 - 96T	RXYQ120-168A REYQ120-168A REYQ120-168X REYQ120-168T	RXYQ192-480A REYQ192-480A REYQ192-336X REYQ192-336T	REYQ360-456X REYQ360-456T
Distributed piping	REFNET header	KHRP25M33H (max. 8 branch)	KHRP25M33H (max. 8 branch) KHRP25M72H (max. 8 branch)	KHRP25M33H (max. 8 branch) KHRP25M72H (max. 8 branch) KHRP25M73HU (max. 8 branch)	KHRP25M33H (max. 8 branch) KHRP25M72H (max. 8 branch) KHRP25M73HU (max. 8 branch)
	REFNET joint	KHRP25A22T KHRP25A33T	KHRP25A22T KHRP25A33T KHRP25M72TU	KHRP25A22T KHRP25A33T KHRP25M72TU KHRP25M73TU	KHRP25A22T KHRP25A33T KHRP25M72TU KHRP25M73TU
Outdoor unit multi connection piping kit		—		BHFP26P100U <sup>1</sup>	BHFP26P151U

<sup>1</sup>Reducer pipe kit KHRP26P100UA is required for REYQ264-480A models

### VRV T-Series Water-Cooled Heat Pump / Heat Recovery and VRV IV-S

UNIT MODEL NUMBER	VRV T-SERIES WATER-COOLED					VRV IV-S
	RWEQ96T	RWEQ120T	RWEQ144T	RWEQ192 - 288T	RWEQ312 - 432T	RXTQ36TBVJUA RXTQ48TBVJUA RXTQ60TBVJUA
REFNET Header	Heat Pump	KHRP26M22H (Max 4 branch) KHRP26M33H (Max 8 branch)	KHRP26M22H (Max 4 branch), KHRP26M33H (Max 8 branch) KHRP26M72H (Max 8 branch)	KHRP26M22H (Max 4 branch), KHRP26M33H (Max 8 branch) KHRP26M72H (Max 8 branch), KHRP26M73HU (Max 8 branch)	KHRP26M22H (Max. 4 branch) KHRP26M33H (Max. 8 branch)	
	Heat Recovery	KHRP25M33H (Max 8 branch)	KHRP25M33H (Max 8 branch) KHRP25M72H (Max 8 branch)	KHRP25M33H (Max 8 branch), KHRP25M72H (Max 8 branch) KHRP25M73HU (Max 8 branch)	—	
REFNET Joint	Heat Pump	KHRP26A22T, KHRP26A33T	KHRP26A22T, KHRP26A33T, KHRP26M72TU	KHRP26A22T, KHRP26A33T, KHRP26M72TU, KHRP26M73TU	KHRP26A22T	
	Heat Recovery	KHRP25A22T, KHRP25A33T	KHRP25A22T, KHRP25A33T, KHRP25M72TU	KHRP25A22T, KHRP25A33T, KHRP25M72TU, KHRP25M73TU	—	
Outdoor Unit Multi Piping Connection Kit	Heat Pump	—			BHFP22T84U	BHFP22T126U
	Heat Recovery	—			BHFP26T84U	BHFP26T126U



### Hail Guard Kits, Snow/Wind Hood Kit

The optional hail guard kit for VRV3-phase enables optimal airflow for efficient heat transfer while providing condenser coil protection from hail damage in severe climates. Each hail guard kit, that is field installed, consists of 4 panels (Right, Left, Front and Back).

#### Hail Guard Kit for VRV IV X, VRV IV, and VRV AURORA

VRV IV	QUANTITY OF KITS PER ODU MODELS					PANEL DIMENSIONS (H X W X D)			
	R_YQ72T	R_YQ96-168T	R_YQ192T	R_YQ216-336T	R_YQ360-456T	Right Panel	Left Panel	Front Panel	Front Panel
VRV AURORA		R_LQ72-120T		R_LQ144-240T					
VRV IV X HP	RXYQ72X	RXYQ96-168X	RXYQ192X	RXYQ216-336X	RXYQ360-456X				
VRV IV X HR		REYQ72-168X		REYQ192-336X	REYQ360-408X				
VRV4HGS-K1	1		1			45 <sup>7</sup> / <sub>8</sub> " x 26" x 4"	45 <sup>7</sup> / <sub>8</sub> " x 12 <sup>7</sup> / <sub>8</sub> " x 4"	45 <sup>7</sup> / <sub>8</sub> " x 13 <sup>1</sup> / <sub>4</sub> " x 4"	45 <sup>7</sup> / <sub>8</sub> " x 32 <sup>5</sup> / <sub>8</sub> " x 4"
VRV4HGL-K1		1	1	2	3			45 <sup>7</sup> / <sub>8</sub> " x 24" x 4"	45 <sup>7</sup> / <sub>8</sub> " x 44 <sup>3</sup> / <sub>4</sub> " x 4"

\*Refer engineering and installation manual for more detail.

#### Hail Guard Kit for VRV EMERION

VRV EMERION	QUANTITY OF KITS PER ODU MODELS		
	RXYQ72A / REYQ72A	RXYQ96-168A / REYQ96-168A	RXYQ192-240A / REYQ192-240A-240A
VRV6HGM-K1	1		
VRV6HGL-K1		1	
VRV6HGX-K1			1



### Snow/Wind Hood Kits

The optional Snow/Wind Hood Kits mount over the heat exchanger coil to protect from snow build-up and wind in cold climates. The Hoods install easily to condensing units using existing screw taps with no modification required. Different kits can be ordered for different job requirements.

VRV IV X, AURORA	KIT PART NUMBER	CHASSIS SIZE	KIT INCLUSION	
	VRV-SHS-FR	Small Chassis	Front Hood	Rear Hood
VRV-SHL-FR	Large Chassis	Front Hood	Rear Hood	
VRV-SH-RL	Both Chassis	Right Hood	Left Hood	
VRV-SHS-T	Small Chassis		Top Hood	
VRV-SHL-T	Large Chassis		Top Hood	

VRV EMERION	KIT PART NUMBER	CHASSIS SIZE	KIT INCLUSION	
	VRV6-SHM-FR	Medium Chassis	Front Hood	Rear Hood
VRV6-SHL-FR	Large Chassis	Front Hood	Rear Hood	
VRV6-SHXL-FR	X-Large Chassis	Front Hood	Rear Hood	
VRV6-SH-RL	All Chassis	Right Hood	Left Hood	
VRV6-SHM-T	Medium Chassis		Top Hood	
VRV6-SHL-T	Large Chassis		Top Hood	
VRV6-SHXL-T	X-Large Chassis		Top Hood	

NUMBER OF KITS REQUIRED FOR EACH OUTDOOR SYSTEM															
MODEL TYPE	NUMBER OF MODULES	VRV6-SHM-FR	VRV6-SHL-FR	VRV6-SHXL-FR	VRV6-SHM-T	VRV6-SHL-T	VRV6-SHXL-T	VRV6-SH-RL	VRV6-SHS-FR	VRV6-SHL-FR	VRV6-SH-RL	VRV6-SHS-T	VRV6-SHL-T	VRV6-SHS-FR	
														VRV6-SHS-FR	
VRV EMERION	208-230V /460V	RXYQ72A, REYQ72A	Single	1				1							
		RXYQ96-168A, REYQ96-168A	Single		1			1							
		RXYQ196-240A, REYQ196-240A	Single			1			1	1					
		RXYQ264-336A, REYQ264-336A	Dual		2				2	1					
		RXYQ360A, REYQ360A	Dual		1	1			1	1	1				
		RXYQ384-480A, REYQ384-480A	Dual					2	1						
VRV AURORA	208-230V /460V / 575V	R_LQ72-120T	Single								1	1		1	
		R_LQ144-240T	Dual								2	1		2	
VRV IV Heat Recovery Heat Pump	208-230V / 460V	R_YQ72T	Single							1		1		1	
		R_YQ96-168T	Single								1	1		1	
		R_YQ192T	Dual							1	1	1		1	
		R_YQ216-336T	Dual								2	1		2	
		R_YQ360-456T*	Triple								3	1		3	
VRV IV X Heat Recovery	208-230V / 460V	REYQ72-168X	Single								1	1		1	
		REYQ192-336X	Dual								2	1		2	
		REYQ360-456X	Triple								3	1		3	
VRV IV X Heat Pump	208-230V / 460V	RXYQ72X	Single								1			1	
		RXYQ96-168X	Single								1	1		1	
		RXYQ192X	Dual								1	1		1	
		RXYQ216-336X	Dual								2	1		2	
		RXYQ360-408X	Triple								3	1		3	

\*Up to 408 on Heat Pump

# Product Portfolio

## Accessories (cont.)



### DZK (Daikin Zoning Kit)



The optional DZK increases the flexibility of the Daikin VRV and SkyAir systems in both residential and commercial applications by adding a Zoning Box to an indoor unit fan coil, allowing several separate ducts to supply air to different individually controlled zones. The DZK BACnet® HUB module will work with any BACnet/IP & BACnet/MSTP compatible Building Management System. The DZK BACnet Hub is now Wi-Fi capable and provides remote access via the Airzone Cloud app or device web browser. (DZK-BACnet-HUB4)

DZK Zoning Box for FXMQ and FXSQ indoor units



Daikin BACnet HUB4 Module



DZK Wired, Wireless, and Wireless Lite thermostat options





### Air treatment systems

Daikin's Outside Air Processing Unit can combine fresh air treatment and air conditioning, supplied from a single system.

The compact Energy Recovery Ventilator is designed to improve indoor air quality while reducing the overall HVAC system power

consumption. This is achieved by providing fresh outside air and recovering waste heat from exhaust air leaving the conditioned space.

BACnet® is a trademark of ASHRAE.

		OUTSIDE AIR PROCESSING UNIT, FXMQ_MVJU	ENERGY RECOVERY VENTILATOR, VAM-GVJU
			
		Connectable	Not connectable
		Connectable	
		Option	Not available
		Air supply	Air supply and Air exhaust
VRV Refrigerant Piping			
VRV Control Wiring			
High Efficiency Filter (MERV 8 and MERV 13)			
Ventilation System			
Power Supply	V/ph/Hz	208-230/1/60	
Airflow Rate	CFM	635	305/300/170
		988	470/470/390
		1236	600/600/500 1200/1200/930







The configurable display and operation buttons on the *Navigation* Remote Controller will provide as much or as little control as the installed *VRV* system requires.







# Product Portfolio

## Controls

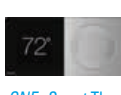

Optimized for VRV technology, Daikin controls provide highly scalable solutions for all applications and budgets. VRV controls offer solutions to meet your project controls needs from individual zone control with local controllers to centrally controlling the building with Centralized Controllers and/or interfacing with Building Management Systems (BMS) for comfort control in an easily managed and operated system.

PROJECT REQUIREMENTS	DAIKIN VRV CONTROLS					
	 Madoka Remote Controller (BRC1H71W)	 DKN Cloud Wi-Fi Adaptor (AZAI6WSCDKA)	 Navigation Remote Controller (BRC1NRV71/72) R32 and R410a	 Daikin ONE+ Smart Thermostat (DTST-CWBSA-NI-B)** R32	 Daikin ONE Touch (DTST-TOU-A) R32	
R32 IDU Compatible			■	■	■	
After Hours Override			■			
Individual zone control	■	■	■	■	■	
Independent cool and heat set-points	■	■	■	■	■	
Individual zone control with weekly programmable scheduling		■	■	■	■	
Basic On/Off control for indoor units	■	■	■	■	■	
Advanced multi-zone control of small to medium size projects						
Advanced multi-zone control of large commercial projects						
Advanced multi-zone control with scheduling logic and calendar						
Automatic cooling/heating changeover for heat pump systems	■	■	■	■	■	
Single input batch shutdown of all connected air handlers						
Web browser control and monitoring						
E-mail notification of system alarms and equipment malfunctions						
Multiple tenant power billing for shared condenser applications						
Temperature set-point range restrictions	■		■	■	■	
Graphical user interface with floor plan layout						
Start/stop control of ancillary building systems*						
Daikin VRV integration with BACnet® based automation systems						
Daikin VRV integration with LonWorks based automation systems						
Daikin VRV integration with Modbus based automation systems		■				
Wi-Fi option remote access through smartphone app		■		■	■	
View service data on a graphical view						
Trend and Plot (Current and Past Data)						
Adjust outdoor unit field settings remotely						
Multisite Monitoring				■	■	
Automated Reports						

\* Requires WAGO® IO module (for use with *iTM* and *HERO* Pro Edge).









\*\* for both the Daikin *One+* and *Touch*. \*\*\*Requires Translation Adaptor DAPT-ONE-VMS. \*DGE601A71 requires the D3/D4 Adaptor (BRD72A-L) to connect R32 VRV equipment.

■ Native application or feature for this device. ■ Dependent upon capabilities of the third party energy management system

BACnet® is a trademark of ASHRAE.



DAIKIN VRV CONTROLS

	 DKN Plus Adaptor (AZAI6WSPDKC) R32	 intelligent Touch Manager with BRD72A-L	 BACnet® Interface with BRD72A-L	 LonWorks® Interface	 Modbus® Interface	 BACnet MSTP Adaptor	 Simple Edge	 HERO Pro Edge*
								■
	■	■	■	■	■	■		■
	■	■				■		
	■	■	■	■	■	■		■
		■	■	■	■	■		■
		■	■	■				■
	■	■						■
		■	■	■	■	■		■
		■	■	■	■	■	■	■
		■	■	■	■	■	■	■
		■	■	■	■	■	■	■
		■	■	■	■	■	■	■
	■	■	■			■		
	■			■				
	■				■			
	■							■
							■	■
							■	■
							■	■
							■	■
							■	■







BACnet® is a trademark of ASHRAE.

# Product Portfolio

## Controls (cont.)



### Network solutions

TYPE		<i>iTM</i>	LonWorks®	BACnet®	ModBus®	BACnet MSTP Adaptor	DKN Plus Interface	HERO Pro Edge
								
Screen	Layout screen	■						Online Dashboard
	Touch screen	■						
Integration	Mini BMS for heating, air conditioning applied systems and refrigeration units (BACnet and WAGO®)	■						■
	3rd party equipment integration	■					Tstat & Aux Heater	■
Control	Basic control functions: on/off, set point setting, air flow settings, operation mode	■	■	■	■	■	■	■
	Temperature limitation	■						■
	Setback	■						■
	Automatic changeover	■					■	■
	Weekly schedule and special day pattern	■					■	■
	Timer extension	■						■
	Forced off	■	■	■		■	■	■
Interlock	■						■	
Monitoring	Basic control functions: ON/OFF status, operation mode, set point temp.	■	■	■	■	■	■	■
	Filter status	■	■	■	■	■	■	■
	Malfunction code	■	■	■	■	■	■	■
	History (Control, malfunction, settings, status)	■						■
	Data storage (indoor and outdoor unit operation data)	■						■
Visualization	■						■	
Options	PPD (Power Proportional Distribution)	■						■
	Web access and control	Standard					Wi-Fi Access	■
	BACnet Client	■						■
	BACnet Server	■				■	■	■
	D-Net Service	■						■
Other	Operation Data	■				■		■
	Maximum number of indoor unit groups	8 x 64	64	4 x 64	16	32	1	8x64

BACnet® is a trademark of ASHRAE.

## Powerful Service Tool with Indoor and Outdoor Unit Operation Data Points

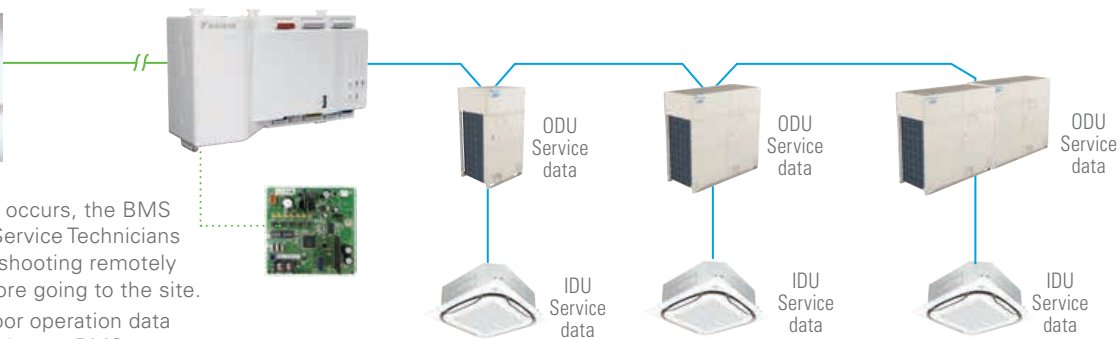
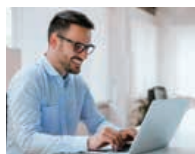

- » When a problem occurs, the BMS integrators and Service Technicians can start troubleshooting remotely immediately before going to the site.
  - » Indoor and outdoor operation data trending\* by Third party BMS can benefit the VRV service process.
- \*BMS programming needed

### Optional

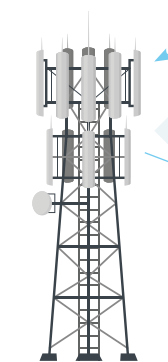
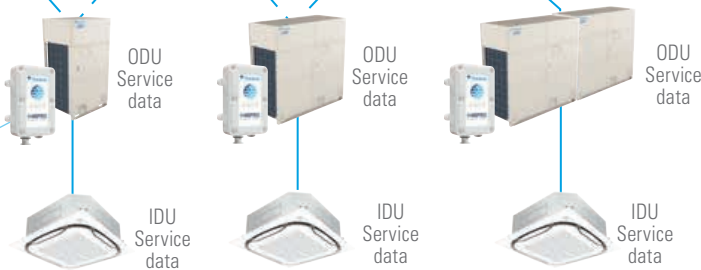

Cell Tower



- » Remotes access to the HVAC to check system health.
- » When a problem occurs, the Service Technicians can start troubleshooting remotely immediately before going to the site.
- » Indoor and outdoor operation data trending via the HERO Cloud Service can benefit the VRV service process.



# Indoor Units



Designed for absolute comfort and versatility, Daikin's wide selection of ducted and duct-free indoor units with a sleek and sophisticated design provides zoning flexibility and comfort control for almost any application.



As many as 64 separate indoor units can be connected to a refrigerant circuit with a single outdoor unit of up to 38 tons capacity. The Daikin VRV indoor unit range is one of the widest on the market, offering no less than 16 stylish and elegant indoor units types in 91 different models — all designed to maximize comfort, minimize operating sound and simplify installation and servicing.

Indoor unit models include *Round Flow* ceiling mounted cassette, ceiling concealed ducted, ceiling suspended, wall mounted and floor standing models.

The *Round Flow* sensing cassette now includes an optional variable refrigerant flow system industry first self-cleaning filter, which automatically cleans itself daily

(user adjustable), leading to yearly energy savings of up to 50%. Dust from the filter is collected in the unit for easy and quick removal (when indicated) with a standard vacuum cleaner.

Designed to fit rooms of any size and shape, Daikin indoor units are also user friendly, ultra reliable, easy to control and quiet in operation.





INDOOR UNIT TYPE	CAPACITY																	
	MBH TONS	5.8 0.5	0.7 0.6	0.9 0.75	12 1	15 1.25	18 1.5	24 2	30 2.5	36 3	42 3.5	48 4	54 4.5	60 5	72 6	96 8		
DUCTED	FXMQ_TBVJU (R-410A) FXMA_AAVJU (R-32) HSP DC Concealed Ducted Unit 																	
	FXSQ_TBVJU (R-410A) FXSA_AAVJU (R-32) MSP Concealed Ducted Unit 																	
	FXTQ_TBVJUA (D) FXTA_AAVJUA (D) (R-32) Multi-Position Air Handling Unit (Upflow, Downflow, Horizontal Left and Horizontal Right) 																	
	FXDQ_MVJU LSP Slim Concealed Ducted Unit																	
	FXMQ_MVJU HSP High Capacity Concealed Ducted Unit																	
DUCT-FREE	FXFQ_TVJU (R-410A) FXFQ_AAVJU (R-32) <i>ROUND FLOW</i> Round Flow Sensing Cassette, Ceiling Mounted 																	
	HXY48TAVJU Low Temperature (LT) Hydrobox																	
	FXUQ_PAVJU 4-Way Blow Ceiling-Suspended Cassette																	
	FXZQ_TBVJU (R-410A) FXZA_AAVJU (R-32) VISTA 2x2 Cassette for VRV 																	
	FXEQ_PVJU Ceiling-Mounted Cassette (Single Flow)																	
	FXHQ_MVJU Ceiling-Suspended Unit																	
	FXAQ_PVJU (R-410A) FXAA_AAVJU (R-32) Wall-Mounted Unit 																	
	FXNQ_MVJU9 Concealed Floor- Standing Unit,																	
	FXLQ_MVJU9 Floor-Standing Unit																	

Comfort cooling/heating Condensate pump standard Outside air connection possible

# Indoor Units Overview



Condensate Pump as Standard



All Aluminum Coil



Optional Auto Cleaning Filter



Outside Air Integration Possible



Variable-Speed ECM Motor



All Aluminum Coil



Filter Included

## What are your choices?

R32

### FXMQ\_TBVCJU (R-410A) FXMA\_AAVJU (R-32) HSP DC Concealed Ducted Unit

Ceiling mounted DC-Ducted unit — ideal for small to large spaces in need of a concealed air-conditioning system.



R32

### FXFQ\_TVVCJU (R-410A) FXFQ\_AAVJU (R-32) Round Flow Sensing Cassette, Ceiling Mounted

Ideal for open plan applications such as classrooms and offices where adaptive comfort control is preferred. Provides excellent comfort level, energy efficiency, and flexibility due to advanced control functions.



R32

### FXSQ\_TBVCJU (R-410A) FXSA\_AAVJU (R-32) MSP Concealed Ducted

Ducted unit with compact design and powerful static pressure capabilities.

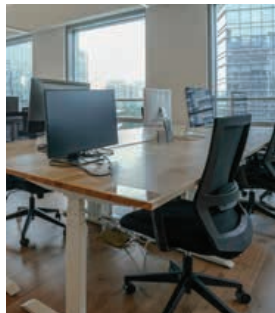
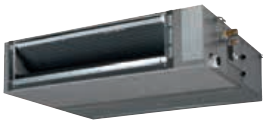

R32

### FXTQ\_TBVCJUA(D) (R410A) FXTA\_AAVJUA(D) (R-32) Multi-Position Air Handling Unit

Vertical air handling unit ideal for both residential and light commercial applications.



It has upflow, downflow, horizontal left and horizontal right possibilities.

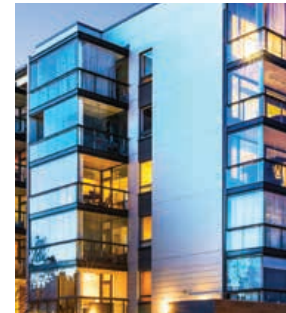

R32

### FXAQ\_PVVCJU (R410A) FXAA\_AAVJU (R-32) Wall-Mounted Unit

Unit ideal for cooling or heating smaller zones such as stores, offices and restaurants. Compact and stylish design.



R32

### FXZQ\_TBVCJU (R410A) FXZA\_AAVJU (R-32) VISTA 2x2 Cassette for VRV

2'x2' 4-way Cassette best for open plan applications such as classrooms, offices and retail.

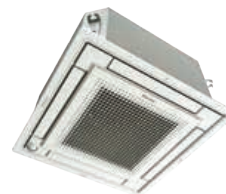

**FXMQ\_MVJU**

**HSP High Capacity Concealed Ducted**

Ideal unit for larger open space floor plans usually found in offices, retails, hotels or education facilities.

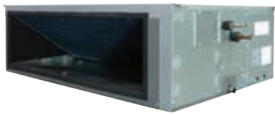

**FXNQ\_MVJU9**

**Concealed Floor-Standing Unit**

Floor-standing unit that can easily be installed along a perimeter wall — or concealed

**FXLQ\_MVJU9**

**Floor-Standing Unit**

Great way to save space. The floor-standing units can easily be installed along a perimeter wall.



**FXUQ\_PAVJU**

**4-Way Blow Ceiling-Suspended Cassette**

Perfect solution for rooms without a false ceiling, or minimal space above a false ceiling, where adaptive comfort control is preferred.



**FXEQ\_PVJU**

**Ceiling-Mounted Cassette (Single Flow)**

Slim and compact design for installation flexibility. For hotel rooms, offices and residential.

**FXHQ\_MVJU**

**Ceiling-Suspended Unit**

Ceiling-suspended with slim and elegant design solution for VRF



**FXDQ\_MVJU**

**LSP Slim Concealed Ducted Unit**

Slim duct built-in concealed unit with low profile and low sound level.



**HXY48TAVJU**

**Low Temperature Hydrobox**

High-efficiency all-electric heat pump hot and chilled water solution for VRF



# FXMQ\_TBVJU

## HSP DC Concealed Ducted Unit



Condensate Pump  
as Standard



Outside Air  
Integration Possible

### Powerful, Concealed, Flexible

The ceiling mounted HSP DC concealed ducted unit is ideal for small to large spaces in need of a concealed air-conditioning system. It is extremely powerful and the compact design allows it to be completely concealed. This makes it perfect for retail, classrooms, offices, banks, restaurants, shops and hotels common areas.

### Features and Benefits

- » Capacity range up to 54 MBH.
  - » Energy efficient due to the DC fan motor
  - » Ideal to use together with the optional Daikin Zoning Kit, DZK
  - » Provides a high degree of control for auxiliary heating devices, with independently configurable on/off temperature values
  - » Advanced economizer control logic
  - » Enhanced indoor air quality and LEED® ready with MERV 13 filter options
  - » Ease of installation with auto adjusting airflow at commissioning based on external static pressure
  - » Flexible ductwork design with ESP capabilities up to 0.8" W.G.
  - » Installation flexibility with a low profile, compact design at less than 12" in height
  - » Easy maintenance with complete service access from below
- \* Refer to installation manual for all installation clearance requirements.  
\*\* Auto fan speed requires the use of the BRC1NRV71/72 controller



BRC1NRV71/72  
(option)



AZAI6WSPDKA  
(option)



BRC4C82  
(option)



BRC1H71W  
(option)



AZAI6WSPDKC  
(option)

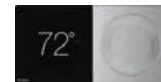

DTST-CWBSA-NI-B  
(option)



DTST-TOU-A  
(option)

### Auto Adjust External Static Pressure

- » After installation, it is possible that the actual duct resistance is lower than expected at the time of designing. As a consequence, the air-flow will be too high.
- » With the automatic air-flow adjustment function the unit can adapt its fan speed to a lower curve, so the air-flow decreases.
- » The air-flow will always be within 10% of the rated air-flow because of the amount of possible fan curves (more than 8 fan curves available per model).
- » Alternatively the installer can manually select a fan curve with the wired remote control.

### Auto Adjust External Static Pressure



- Fan characteristic curve
- Actual duct resistance curve
- - - Duct resistance curve at the time of designing
- Rated airflow
- Airflow without airflow automatic adjustment
- Actual airflow

### Applications

- » Offices
- » Hotels
- » Schools
- » Retail

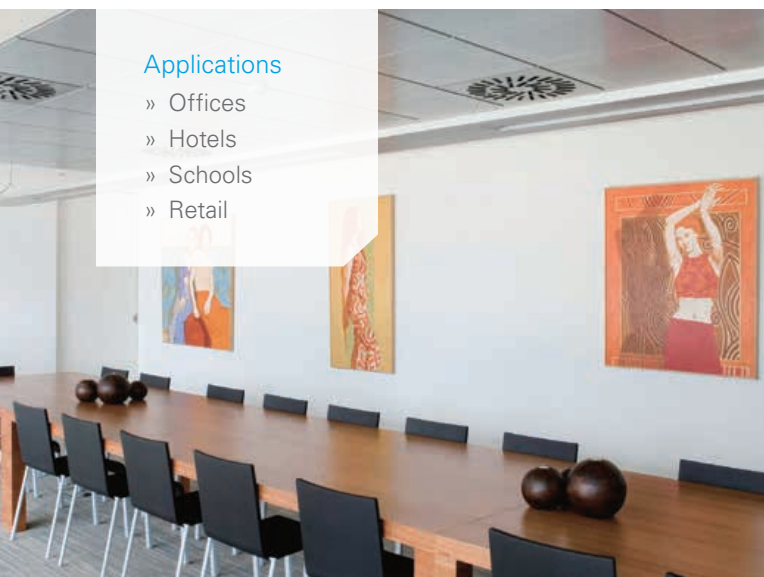

FXMQ_TBVJU SPECIFICATIONS		1.25 TON	1.5 TON	2.0 TON	2.5 TON	3.0 TON	4.0 TON	4.5 TON
Model Name		FXMQ15TBVJU	FXMQ18TBVJU	FXMQ24TBVJU	FXMQ30TBVJU	FXMQ36TBVJU	FXMQ48TBVJU	FXMQ54TBVJU
Power Supply	V/ph/Hz	Single-phase 208/230V 60Hz						
Rated Cooling Capacity	BTU/h	14,200 (4.2)	18,000 (5.3)	24,000 (7.0)	30,000 (8.8)	36,000 (10.6)	48,000 (14.1)	54,000 (16.7)
Rated Heating Capacity	BTU/h	17,000 (5.0)	20,000 (5.9)	27,000 (7.9)	34,000 (10.0)	40,000 (11.7)	54,000 (15.8)	63,000 (18.5)
Airflow Rate (H/M/L)	SCFM (M3/MIN)	560/447/406 (15.8/12.7/11.5)	635/565/512 (18.0/16.0/14.5)	742/635/565 (21.0/18.0/16.0)	1094/847/795 (31.0/24/22.5)	1130/953/795 (32.0/27.0/22.5)	1377/1130/918 (39.0/32.0/26.0)	1518/1235/989 (43.0/35.0/28.0)
Height	in.	9-11/16						
Width	in.	39-3/8			55-1/8			61
Depth	in.	31-1/2						
Condensate Pump Lift	in.	25-5/16						
Sound Level (Reference) *	Power dB(A)	65	64	67	71	72	76	80
	Pressure dB(A)	37/34/31	36/34/32	39/35/33	43/38/36	44/40/36	48/44/39	52/47/42
Weight	lbs (kg)	77 (35)		82 (37)	101 (46)		104 (47)	115 (52)
Condensate Pipe Connection	in. O.D.	VP25						
Pipe Connections	Gas	in. (mm)	ø1/4 (ø6.4) (Flare)			ø3/8 (ø9.5) (Flare)		
	Liquid	in. (mm)	ø1/2 (ø12.7) (Flare)			ø5/8 (ø15.9) Flare		
Refrigerant		R-410A						
Refrigerant Control		Electronic Expansion Valve						
Maximum Overcurrent Protective Device	A	15						
Minimum Circuit Amps	A	1.8	1.9		3	3.1	3.6	
Protection Devices		Fuse and Fan Driver Overload Protector						
External Finish		Galvanized Steel Plate						
External Static Pressure (H/L)	in. W.G.	0.80/0.20						0.56/0.20

\* The sound power levels are based on ISO9614 and the sound pressure levels are based on JIS B 8616.

#### FXMQ\_TBVJU ACCESSORIES

Model Name	FXMQ15TBVJU	FXMQ18TBVJU	FXMQ24TBVJU	FXMQ30TBVJU	FXMQ36TBVJU	FXMQ48TBVJU	FXMQ54TBVJU
Navigation Remote Controller*				BRC1NRV71/72			
DKN Cloud Wi-Fi Adaptor				AZAI6WSCDKA			
Madoka Remote Controller				BRC1H71W			
Button Sensor Kit				KRCSH2018-02			
Daikin ONE+ Smart Thermostat				DTST-CWBSA-NI-B			
DKN Plus Interface				AZAI6WSPDKC			
Daikin ONE Touch				DTST-TOU-A			
Wireless Remote Controller				BRC4C82			
Remote Sensor Kit				KRCS01-6B			
Wiring Adaptor PCB (interface with aux/primary heater, humidifier, OA damper/fan)				KRP1C75			
Group Control Adaptor PCB (connects to external BMS)				KRP4A74			

\* Optional face plates available to provide a more intuitive user interface and disable specific functions

#### FXMQ\_TBVJU INSTALLATION SPACE

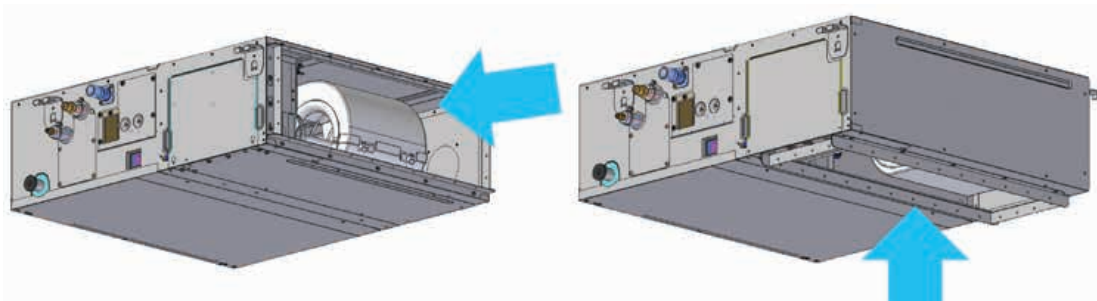

# FXSQ\_TBVJU

## MSP Concealed Ducted Unit



Condensate Pump  
as Standard



Outside Air  
Integration Possible

### Do more with less

The MSP concealed ducted unit is engineered with impressive static pressure capability in a compact, flexible chassis design to give designers a tool to approach even the most cramped air conditioning applications.

### Features and Benefits

- » Powerful static pressure capability, with up to 0.6 in. Wg (150Pa) external static pressure.
- » Ease of installation with auto adjusting airflow at commissioning based on external static pressure.
- » Designed for installation flexibility, with a factory rear-return configuration and field convertible to bottom return.
- » Sound levels as low as 28 dB(A) for quiet operation.
- » Provides a high degree of control for auxiliary heating devices, with independently configurable on/off temperature values.
- » Integral condensate pump with up to 25-5/16" (643mm) of lift from the drain outlet



BRC1NRV71/72  
(option)



AZAI6WSCDKA  
(option)



BRC4C82  
(option)



BRC1H71W  
(option)



AZAI6WSPDKC  
(option)

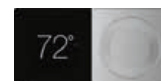

DTST-CWBSA-NI-B  
(option)



DTST-TOU-A  
(option)

### Flexible Installation

The FXSQ\_TB can easily be converted to a bottom-return configuration to optimize the use of space above the ceiling or bulkhead space.



### Applications

- » Offices
- » Hotel Rooms
- » Multi-family residences
- » Single-family residences
- » Schools



SPECIFICATIONS		0.5 TON	0.6 TON	0.75 TON	1.0 TON	1.25 TON	1.5 TON	
Model Name		FXSQ05TBVJU	FXSQ07TBVJU	FXSQ09TBVJU	FXSQ12TBVJU	FXSQ15TBVJU	FXSQ18TBVJU	
Capacity Index		5.8	7.5	9.5	12	15	18	
Power Supply	V/ph/Hz	208/230VAC, 60Hz, 1 phase						
Nominal Cooling Capacity*1	Btu/h (kW)	5,800 (1.7)	7,200 (2.1)	9,500 (2.8)	12,000 (3.5)	15,000 (4.4)	18,000 (5.3)	
Nominal Heating Capacity*2	Btu/h (kW)	6,500 (1.9)	8,500 (2.5)	10,500 (3.1)	13,500 (4.0)	17,000 (5.0)	20,000 (5.9)	
Fan	Type	Sirocco fan						
	Motor Output	W				78	130	230
	Air Flow Rate (H/M/L)	CFM		281 / 265 / 230	318 / 265 / 230	335 / 283 / 247	530 / 441 / 371	600 / 512 / 406
	Drive Type	DC Direct Drive						
	External Static Pressure (Std./Max)	0.2 / 0.6				0.4 / 0.6		
Height	in. (mm)	9-11/16						
Width	in. (mm)	21-11/16				27-9/16	39-3/8	
Depth	in. (mm)	31-1/2						
Weight (net)	lb. (kg)	55 (25)				60 (27)	77 (35)	
Condensate Pump Lift	in. (mm)	25-5/16 (643)						
Sound Pressure Level (H/M/L speed)	dB(A)	33 / 30 / 28			34 / 32 / 30	36 / 33 / 30	34 / 32 / 29	
Pipe Connections	Liquid	in. 1/4 (Flare)						
	Gas	in. 1/2 (Flare)						
	Condensate Drain	in. VP25						
Refrigerant Control	Electronic Expansion Valve							
Maximum Overcurrent Protection Device	A	15						
Minimum Circuit Ampacity	A	0.8				1.4	1.6	

SPECIFICATIONS		2.0 TON	2.5 TON	3.0 TON	4.0 TON	4.5 TON		
Model Name		FXSQ24TBVJU	FXSQ30TBVJU	FXSQ36TBVJU	FXSQ48TBVJU	FXSQ54TBVJU		
Capacity Index		24	30	36	48	54		
Power Supply	V/ph/Hz	208/230VAC, 60Hz, 1 phase						
Nominal Cooling Capacity*1	Btu/h (kW)	24,000 (7.0)	30,000 (8.8)	36,000 (10.6)	48,000 (14.1)	54,000 (15.8)		
Nominal Heating Capacity*2	Btu/h (kW)	27,000 (7.9)	34,000 (10.0)	40,000 (11.7)	54,000 (15.8)	60,000 (17.6)		
Fan	Type	Sirocco fan						
	Motor Output	W		230	300		350	
	Air Flow Rate (H/M/L)	CFM		742 / 618 / 512	812 / 689 / 565	1130 / 953 / 795	1307 / 1112 / 918	1377 / 1183 / 989
	Drive Type	DC Direct Drive						
	External Static Pressure (Std./Max)	0.2 / 0.6				0.2 / 0.56		
Height	in. (mm)	9-11/16						
Width	in. (mm)	39-3/8		55-1/8		61		
Depth	in. (mm)	31-1/2						
Weight (net)	lb. (kg)	77 (35)	82 (37)	101 (46)	104 (47)	115 (52)		
Condensate Pump Lift	in. (mm)	25-5/16 (643 mm)						
Sound Pressure Level (H/M/L speed)	dB(A)	36 / 32 / 29	37.5 / 34 / 30	39 / 35 / 32	42 / 38.5 / 35	43 / 40 / 36		
Pipe Connections	Liquid	in. 3/8 (Flare)						
	Gas	in. 5/8 (Flare)						
	Condensate Drain	in. VP25						
Refrigerant Control	Electronic Expansion Valve							
Maximum Overcurrent Protection Device	A	15						
Minimum Circuit Ampacity	A	1.8		2.5	2.8	3.3		

**Notes:** \*1 Nominal cooling capacities are based on the following conditions: 80°F DB / 67°F WB (26.7°C DB / 19.4°C WB) return air temperature; 95°F DB (35°C DB) outdoor temperature; 25 ft. (7.6 m) equivalent refrigerant piping.

\*2 Nominal heating capacities are based on the following conditions: 70°F DB (21.1°C DB) return air temperature; 47°F DB / 43°F WB (8.3°C DB / 6.1°C WB) outdoor temperature; 25 ft. (7.6 m) equivalent refrigerant piping.

## FXSQ

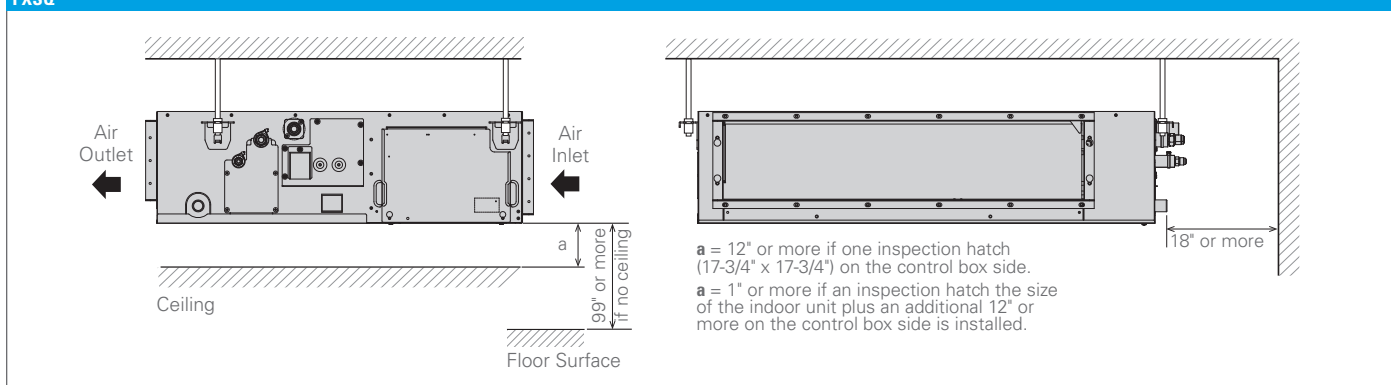

# FXDQ\_MVJU

## LSP Slim Concealed Ducted Unit



Condensate Pump  
as Standard



Outside Air  
Integration Possible



Filter  
Included

### Concealed, Slim, Quiet, Comfortable

The LSP slim concealed unit is available for use with the VRV systems to complement the existing concealed ceiling unit options. With its low profile and low sound level this unit can be installed into limited ceiling void, bulkhead or soffit space.

#### Features and Benefits

- » Slim height, at only 7 $\frac{7}{8}$ "", makes it suitable for most of the applications where attic / bulkhead space is limited
- » With a sound level down to 29 dB(A) these units are among the quietest on the market
- » Factory shipped for rear air inlet — field convertible to bottom air inlet
- » Washable filter included
- » Condensate pump with vertical lift of up to 21 $\frac{5}{8}$ " included as standard
- » Blends unobtrusively with any interior decor; only the suction and discharge grills are visible

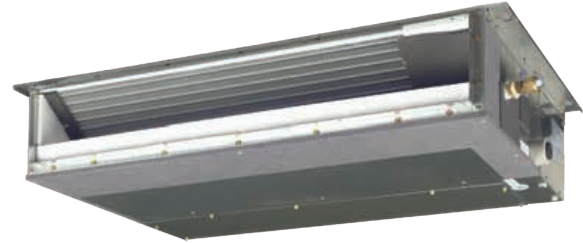

BRC1NRV71/72  
(option)



AZAI6WSCDKA  
(option)



BRC4C82  
(option)



BRC1H71W  
(option)



AZAI6WSPDKC  
(option)

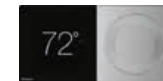

DTST-CWBSA-NI-B  
(option)



DTST-TOU-A  
(option)

#### Applications

- » Hotel rooms
- » Multi-family residences
- » Single family residences
- » School dormitories





FXDQ_MVJU SPECIFICATIONS			0.6 TON	0.75 TON	1 TON	1.5 TONS	2 TONS
Model Name			FXDQ07MVJU	FXDQ09MVJU	FXDQ12MVJU	FXDQ18MVJU	FXDQ24MVJU
Power Supply	V/ph/Hz		208-230/1/60				
Rated Cooling Capacity	BTU/h		7,500	9,500	12,000	18,000	24,000
Rated Heating Capacity	BTU/h		8,500	10,500	13,500	20,000	27,000
Airflow Rate (H/L)	CFM		280/226		440/350		580/460
Weight	lbs.		51		63		71
Height	in.		7-7/8				
Width	in.		27-9/16		35-7/16		43-5/16
Depth	in.		24-7/16				
Sound Pressure (H/L)	dB(A)		33/29		35/31		36/32
Condensate Pump Lift	in.		21-5/8				
Condensate Pipe Connection	in. O.D.		1-1/32				
Pipe Connections	Gas	in.	1/2 (Flare)		5/8 (Flare)		
	Liquid	in.	1/4 (Flare)		3/8 (Flare)		
Refrigerant			R-410A				
Refrigerant Control			Electronic Expansion Valve				
Maximum Overcurrent Protective Device	A		15				
Minimum Circuit Amps	A		0.9		1.3		1.4
Protection Devices			Fuse and Fan Motor Thermal Protector				
External Finish			Galvanized Steel Plate				
Standard Filter Type			Removable, Washable, Mildew Proof				
External Static Pressure (H/L)	in. Wg		0.12/0.04		0.17/0.06		0.17/0.06

**Nominal Conditions:**

**Cooling Mode**

Indoor: 80°F DB / 67°F WB  
 Outdoor: 95°F DB  
 Pipe Length: 25 ft.  
 Level Difference: 0 ft.

**Heating Mode**

Indoor: 70°F DB  
 Outdoor: 47°F DB / 43°F WB  
 Pipe Length: 25 ft.  
 Level Difference: 0 ft.

**Note:** Specifications are subject to change without notice.

**FXDQ\_MVJU ACCESSORIES**

Model Name	FXDQ07MVJU	FXDQ09MVJU	FXDQ12MVJU	FXDQ18MVJU	FXDQ24MVJU
Navigation Remote Controller*			BRC1NRV71/72		
DKN Cloud Wi-Fi Adaptor			AZAI6WSDKA		
Madoka Remote Controller			BRC1H71W		
Button Sensor Kit			KRCSH2018-02		
Daikin ONE+ Smart Thermostat			DTST-CWBSA-NI-B		
DKN Plus Interface			AZAI6WSPDKC		
Daikin ONE Touch			DTST-TOU-A		
Wireless Remote Controller			BRC4C82		
Remote Sensor Kit			KRCS01-1B		
Wiring Adaptor PCB (interface with aux/primary heater, humidifier, OA damper/fan)			KRP1C75		
Group Control Adaptor PCB (connects to external BMS)			KRP4A74		
Access Panel (single door)		APFXDQ070912		APFXDQ18	APFXDQ24
Access Panel with return air filter (single door)		APRFFXDQ070912		APRFFXDQ18	APRFFXDQ24
Filter Media Replacement		APRFFXDQ070912F		APRFFXDQ18F	APRFFXDQ24F

\* Optional face plates available to provide a more intuitive user interface and disable specific functions

**FXDQ\_MVJU INSTALLATION SPACE**

Choose an installation site that ensures both optimum air distribution and sufficient clearance for maintenance.

The return air inlet can be easily changed from rear to bottom using the same chamber lid.

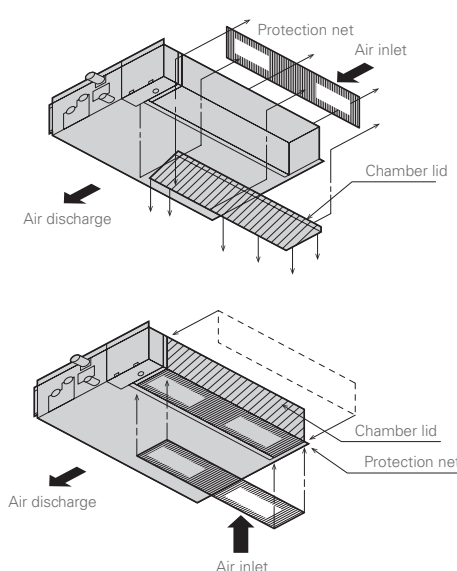
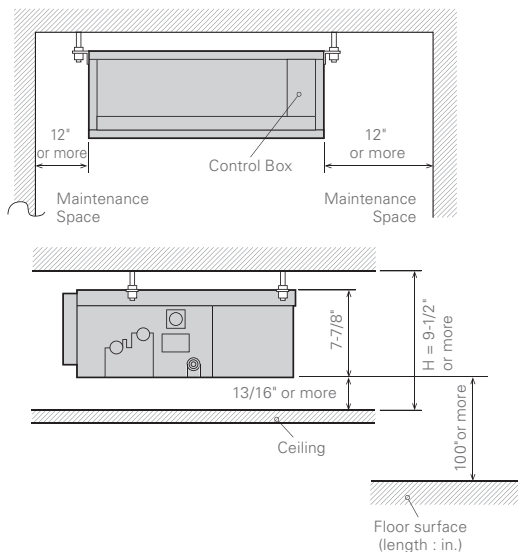

# FXTQ\_TBVJUA(D)

## Multi-Position Air Handling Unit



Outside Air Integration Possible



All Aluminum Coil



Variable Speed ECM Motor

### Outstanding flexibility and performance

The FXTQ\_TAVJUA(D) air handler features full multi-position\* flexibility to meet the most demanding installation conditions. A multitude of features ensure reliable, efficient performance year round.

#### Features and Benefits

- » Expanded capacity lineup, featuring ten models ranging from ¾ ton to 5 tons, with a redesigned\*\* unit frame for maximum durability.
- » Full multi-position air handler capable of upflow, downflow\*, horizontal right, and horizontal left installation.
- » A high efficiency, ECM motor powers the fan to deliver nominal CFM at up to 0.9" in. Wg static. An auto fan speed setting automatically adjusts the fan speed through 5 steps based on the load in the space.
- » Wide line up of electric heat (field installed) options from 3kW to 25kW.
- » An auxiliary heat logic features a reduced heater operation deadband and the ability to run both heat pump and auxiliary heat for maximum comfort and performance in colder climates. The auxiliary heat can be interlocked with the ambient temperature sensed by the outdoor unit.
- » Designed with less than 2% air leakage when tested in accordance with ASHRAE standard 193.
- » New integrated control board reduces\*\* the number of electrical connections required. Quick disconnect control wiring terminals simplify installation.
- » Easily integrate with third party accessories such as a humidifier or economizer with on-board contacts.



AZAI6WSCDKA (option)

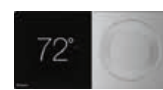

DTST-CWBSA-NI-B (option)



BRC1H71W (option)



AZAI6WSPDKC (option)



BRC1NRV71/72 (option)



DTST-TOU-A (option)

» Up to 200% connection ratio is possible on applicable VRV IV systems.

» Available with optional factory installed disconnect (Built to order — model FXTQ\_TAVJUD.)

\*Downflow requires field installed optional downflow accessory. (Part number DFK-B/C/D)

\*\*Compared to previous model FXTQ\_P

### Designed for Compact Spaces

With its compact and space saving design, the new FXTQ\_TAVJUA(D) air handler units are engineered to suit most light commercial and residential applications.

- » At under 46" tall and only 17-1/2" wide up to 3 tons, the FXTQ\_TAVJUA(D) can be installed in tight closet spaces.
- » Designed for zero clearance on three sides and only 24" clearance on the front for service.
- » Sound levels as low as 36 dBA to suit applications in sound sensitive environments.

#### Applications

- » Multi-family
- » Single-family
- » Hotels
- » Offices

### Electric Heater Options

#### ELECTRICAL HEATER CAPACITY

Model Name	3kW	5kW	6kW	8kW	10kW	15kW	19kW	20kW	25kW
FXTQ09TBVJUA(D)	■	■							
FXTQ12TBVJUA(D)	■	■	■						
FXTQ18TBVJUA(D)	■	■	■	■	■				
FXTQ24TBVJUA(D)	■	■	■	■	■				
FXTQ30TBVJUA(D)	■	■	■	■	■				
FXTQ36TBVJUA(D)	■	■	■	■	■				
FXTQ42TBVJUA(D)		■	■	■	■	■	■		
FXTQ48TBVJUA(D)		■	■	■	■	■	■		
FXTQ54TBVJUA(D)		■	■	■	■	■	■	■	■
FXTQ60TBVJUA(D)		■	■	■	■	■	■	■	■

SPECIFICATIONS			0.75 TON	1 TON	1.5 TON	2 TON	2.5 TON	
Model Name			FXTQ09TBVJUA	FXTQ12TBVJUA	FXTQ18TBVJUA	FXTQ24TBVJUA	FXTQ30TBVJUA	
Model Name (With factory disconnect)			FXTQ09TBVJUD	FXTQ12TBVJUD	FXTQ18TBVJUD	FXTQ24TBVJUD	FXTQ30TBVJUD	
Power Supply	V/ph/Hz	208/230VAC, 60Hz, 1 phase						
Nominal Cooling Capacity*1	Btu/h	9,500	12,000	18,000	24,000	30,000		
Nominal Heating Capacity*2	Btu/h	10,500	13,500	20,000	27,000	34,000		
Fan	Type	Sirocco FC Centrifugal						
	Motor Output	HP	1/2					
	Air Flow Rate (H/M/L)	CFM	300 / 275 / 250	400 / 340 / 280	600 / 510 / 420	800 / 680 / 560	1000 / 850 / 700	
	Static Pressure*3	in. Wg	0.18" / 0.9"				0.23" / 0.9"	
	Drive Type	Variable speed ECM						
Height	in.	45						
Width	in.	17.5						
Depth	in.	21						
Weight (net) (TAVJUA/TAVJUD)	lbs.	105/108	112/115	111/118	112/115	113/116		
Sound Pressure Level (H speed)	dB(A)	36			45		52	
Pipe Connections	Liquid	in.	1/4 (Braze)			3/8 (Braze)		
	Gas	in.	1/2 (Braze)			5/8 (Braze)		
	Condensate Drain	in.	3/4 (fpt)					
Refrigerant Control	Electronic Expansion Valve							
Maximum Overcurrent Protective Device	A	15						
Minimum Circuit Amps	A	4.9						

SPECIFICATIONS			3 TON	3.5 TON	4 TON	4.5 TON	5 TON	
Model Name			FXTQ36TBVJUA	FXTQ42TBVJUA	FXTQ48TBVJUA	FXTQ54TBVJUA	FXTQ60TBVJUA	
Model Name (With factory disconnect)			FXTQ36TBVJUD	FXTQ42TBVJUD	FXTQ48TBVJUD	FXTQ54TBVJUD	FXTQ60TBVJUD	
Power Supply	V/ph/Hz	208/230VAC, 60Hz, 1 phase						
Nominal Cooling Capacity*1	Btu/h	36,000	42,000	48,000	54,000	60,000		
Nominal Heating Capacity*2	Btu/h	40,000	46,000	54,000	60,000	66,000		
Fan	Type	Sirocco FC Centrifugal						
	Motor Output	HP	1/2	3/4			1.0	
	Air Flow Rate (H/M/L)	CFM	1050 / 900 / 750	1400 / 1190 / 980	1520 / 1290 / 1060	1800 / 1530 / 1260	1800 / 1530 / 120	
	Static Pressure*3	in. Wg	0.23" / 0.9"				0.28" / 0.9"	
	Drive Type	Variable speed ECM						
Height	in.	45	53.43			58		
Width	in.	17.5	21			24.5		
Depth	in.	21						
Weight (net) (TBVJUA/TBVJUD)	lbs.	113/116	144/147			165/168		
Sound Pressure Level (H speed)	dB(A)	52	54			50		
Pipe Connections	Liquid	in.	3/8 (Braze)					
	Gas	in.	5/8 (Braze)					
	Condensate Drain	in.	3/4 (fpt)					
Refrigerant Control	Electronic Expansion Valve							
Maximum Overcurrent Protective Device	A	15						
Minimum Circuit Amps	A	4.9	6.5			8.6		

**Notes:** \*1 Nominal cooling capacities are based on the following conditions: 80°F DB / 67°F WB (26.7°C DB / 19.4°C WB) return air temperature; 95°F DB (35°C DB) outdoor temperature; 25 ft. (7.6 m) equivalent refrigerant piping.

\*2 Nominal heating capacities are based on the following conditions: 70°F DB (21.1°C DB) return air temperature; 47°F DB / 43°F WB (8.3°C DB / 6.1°C WB) outdoor temperature; 25 ft. (7.6 m) equivalent refrigerant piping.

\*3 External static pressures are indicated as rated / maximum allowable range.

FXTQ_TBVJUA(D) ACCESSORIES					
Model Name	FXTQ36TBVJUA(D)	FXTQ42TBVJUA(D)	FXTQ48TBVJUA(D)	FXTQ54TBVJUA(D)	FXTQ60TBVJUA(D)
Navigation Remote Controller*	BRC1NRV71/72				
DKN Cloud Wi-Fi Adaptor	AZA16WSCDKA				
Madoka Remote Controller	BRC1H71W				
Button Sensor Kit	KRCSH2018-02				
Daikin ONE+ Smart Thermostat	DTST-CWBSA-NI-B				
DKN Plus Interface	AZA16WSPDKC				
Daikin ONE Touch	DTST-TOU-A				
Wireless Remote Controller	BRC4C82				
Remote Sensor Kit	KRCS01-1B				
Wiring Adaptor PCB (interface with aux/primary heater, humidifier, OA damper/fan)	KRP1C75				
Group Control Adaptor PCB (connects to external BMS)	KRP4A74				

\* Optional face plates available to provide a more intuitive user interface and disable specific functions

# FXMQ\_MVJU

## HSP High Capacity Concealed Ducted Unit



Outside Air  
Integration Possible

### Do More with Less

Daikin's large capacity FXMQ\_MVJU Concealed Ducted unit offers designers a option to provide a large impact in a small space. The large capacity FXMQ features a high efficiency DC fan motor delivering CFM up to 1.0" external static pressure. With the ability to remotely adjust the static pressure, the installation of Daikin VRV equipment is now even easier than before!

### Features and Benefits

- » Powerful static pressure capability, with up to 1.0 in.w.g. (249Pa) external static pressure.
- » Ease of installation with remotely adjustable external static pressure using a *Navigation* Remote Controller (BRC1NRV71/72).
- » Designed for easier servicing and maintenance (compared to previous model) with 2 removable service panels for inspection of the interior or drain pan.
- » Sound levels as low as 28 dB(A) for quiet operation.
- » Includes a standard 1" filter rack for faster installation in the field, filter to be field provided
- » High levels of flexibility with 3 separate fan speeds along with a variety of fan curves.

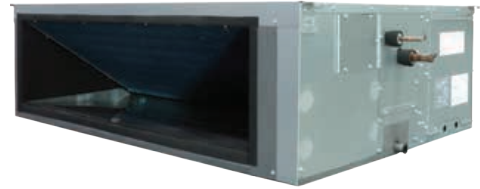

BRC1NRV71/72  
(option)



AZAI6WSCDKA  
(option)



BRC4C82  
(option)



BRC1H71W  
(option)



AZAI6WSPDKC  
(option)

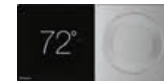

DTST-CWBSA-NI-B  
(option)



DTST-TOU-A  
(option)

### Applications

- » Hotel/conference centers
- » Schools
- » Retail/shopping centers
- » Large open-plan offices
- » Churches

**FXMQ\_MVJU ACCESSORIES**

Model Name	FXMQ96MVJU
Navigation Remote Controller*	BRC1NRV71/72
DKN Cloud Wi-Fi Adaptor	AZA16WSCDKA
Madoka Remote Controller	BRC1H71W
Button Sensor Kit	KRCSH2018-02
Daikin ONE+ Smart Thermostat	DTST-CWBSA-NI-B
Daikin ONE Touch	DTST-TOU-A
DKN Plus Interface	AZA16WSPDKC
Adaptive Touch Controller	BACRC-T-P01/ BACRC-TH-P01/ BACRC-THO-P01/ BACRC-THOC-P01
Wireless Remote Controller	BRC4C82
Remote Sensor Kit	KRCS01-1B
Wiring Adaptor PCB (interface with aux/primary heater, humidifier, OA damper/fan)	KRP1C74
Group Control Adaptor PCB (connects to external BMS)	KRP4A71
High Efficiency Filter Kit (MERV 13)	DACA-MQ96M-13-1K
High Efficiency Filter Kit (MERV 8)	DACA-MQ96M-8-1K

\* Optional face plates available to provide a more intuitive user interface and disable specific functions

**FXMQ\_MVJU INSTALLATION SPACE**

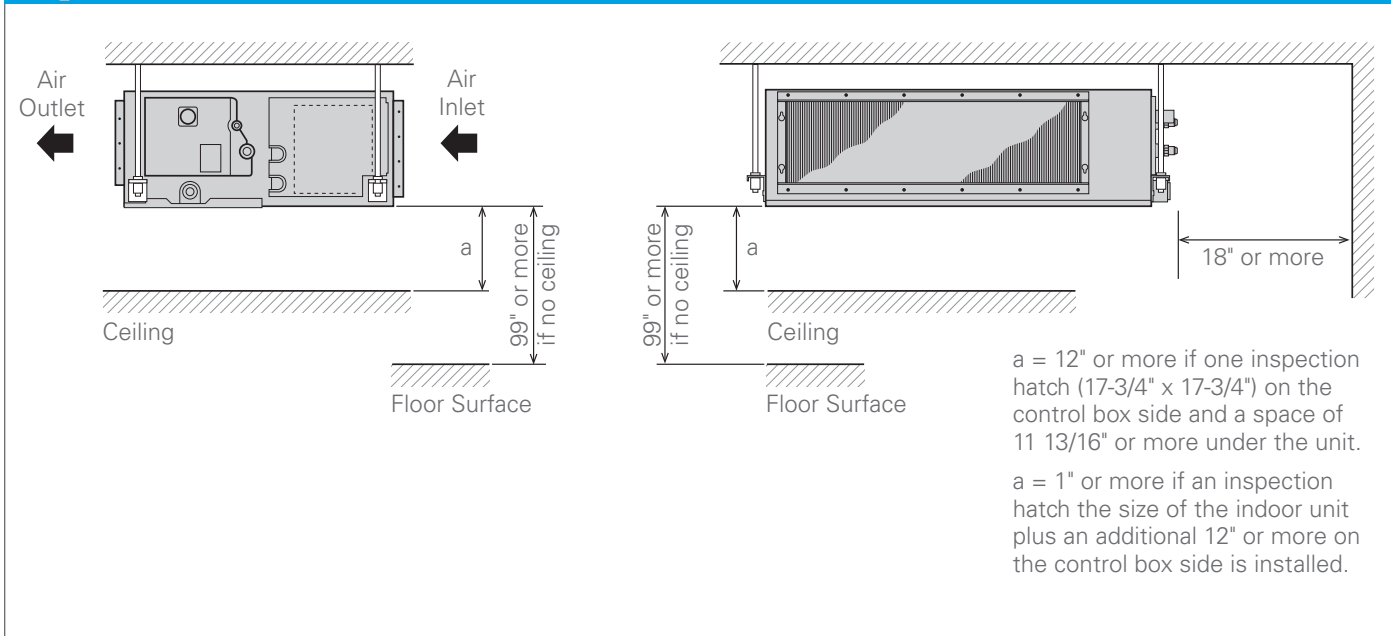

# FXNQ\_MVJU9

## Concealed Floor-Standing Unit



Outside Air  
Integration Possible

Filter  
Included

### Versatile, Logical, Durable, Quiet

The ideal way to save space, our floor-standing units can easily be installed along a perimeter wall — or concealed. The air distribution from these models will allow you to find the right balance for classrooms, churches, office hallways or similar spaces. The concealed floor units cover a wide range of capacities and can be built into counter in order to maintain the aesthetics of the room.

#### Features and Benefits

- » Ideal for installation beneath a window
- » Unit requires minimal installation space
- » Fitted with a washable long-life filter
- » Remote-control options available
- » Space-saving unit can be freestanding or wall-mounted, concealed or exposed
- » Models range from 7.5 MBH to 24 MBH



BRC1NRV71/72  
(option)



AZA16WSCDKA  
(option)



BRC4C82  
(option)



BRC1H71W  
(option)



AZA16WSPDKC  
(option)

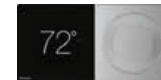

DTST-CWBSA-NI-B  
(option)



DTST-TOU-A  
(option)

#### Applications

- » Multi-family residences
- » Single-family residences
- » Churches
- » Historic buildings
- » Schools
- » Offices



FXNQ_MVJU9 SPECIFICATIONS		0.6 TON	0.75 TON	1 TON	1.5 TON	2 TON
Model Name		FXNQ07MVJU9	FXNQ09MVJU9	FXNQ12MVJU9	FXNQ18MVJU9	FXNQ24MVJU9
Power Supply	V/ph/Hz	208-230/1/60				
Rated Cooling Capacity	BTU/h	7,500	9,500	12,000	18,000	24,000
Rated Heating Capacity	BTU/h	8,500	10,500	13,500	20,000	27,000
Airflow Rate (H/L)	CFM	245/210		280/210	490/380	560/420
Weight	lbs.	47		56	60	
Height	in.	24				
Width	in.	36-5/8		42-1/8	53-1/8	
Depth	in.				8-5/8	
Sound Pressure (H/L)	dB(A)	35/32		36/33	40/35	41/36
Condensate Pipe Connection	in. O.D.	27/32				
Pipe Connections	Gas	in.			1/2	
	Liquid	in.			1/4	
Refrigerant		R-410A				
Refrigerant Control		Electronic Expansion Valve				
Maximum Overcurrent Protective Device	A	15				
Minimum Circuit Amps	A	0.3		0.5	0.6	
Protection Devices		Fuse and Fan Motor Thermal Protector				
External Finish		Galvanized Steel Plate				
Standard Filter Type		Resin Net (with Mold Resistant)				

**Nominal Conditions:**

**Cooling Mode**

Indoor: 80°F DB / 67°F WB  
 Outdoor: 95°F DB  
 Pipe Length: 25 ft.  
 Level Difference: 0 ft.

**Heating Mode**

Indoor: 70°F DB  
 Outdoor: 47°F DB / 43°F WB  
 Pipe Length: 25 ft.  
 Level Difference: 0 ft.

**Note:** Specifications are subject to change without notice.

**FXNQ\_MVJU9 ACCESSORIES**

Model Name	FXNQ07MVJU9	FXNQ09MVJU9	FXNQ12MVJU9	FXNQ18MVJU9	FXNQ24MVJU9
Navigation Remote Controller			BRC1NRV71/72		
DKN Cloud Wi-Fi Adaptor			AZAI6WSDCKA		
Madoka Remote Controller			BRC1H71W		
Button Sensor Kit			KRCSH2018-02		
Daikin ONE+ Smart Thermostat			DTST-CWBSA-NI-B		
DKN Plus Interface			AZAI6WSPDKC		
Daikin ONE Touch			DTST-TOU-A		
Wireless Remote Controller			BRC4C82		
Remote Sensor Kit			KRCS01-1B		
Wiring Adaptor PCB (interface with aux/primary heater, humidifier, OA damper/fan)			KRP1C74		
Group Control Adaptor PCB (connects to external BMS)			KRP4A71		
Condensate Pump			DACA-CP3-1		

\* Optional face plates available to provide a more intuitive user interface and disable specific functions

**FXNQ\_MVJU9 INSTALLATION SPACE**

**IMPORTANT**  
 Leave sufficient clearance for air inlet and maintenance.

MODEL	A (IN.)	B (IN.)
FXNQ12MVJU9	28	46
FXNQ18 - 24MVJU9	39	57
FXNQ07-09MVJU	23	41

# FXFQ\_AAVJU

## Round Flow Sensing Cassette



Condensate Pump as Standard



Outside Air Integration Possible



Filter Included



Optional Auto Cleaning Filter



Surface & Occupancy Sensor Kit as Standard

### Round Flow Sensing Cassette FXFQ-AAVJU

The *Round Flow Sensing Cassette* is ideal for open plan applications such as classrooms and offices where adaptive comfort control is preferred. The unit provides an excellent comfort level, energy efficiency, and flexibility due to advanced control functions based on input from three room sensors (occupancy, air temperature, and surface temperature). With 18 configurable airflow distribution patterns, it can be efficient and provide a comfortable environment in smaller, more intricate spaces as well.

#### Features and Benefits

- » Capacity range from 0.6 TO 4.5 Tons
- » True 360° Airflow and three room sensors enables optimized occupant comfort and efficiency
- » Energy efficient with DC fan motor and auto-logic that adjusts fan speed based on space load
- » Optional self-cleaning filter panel to further increase efficiency and reduce maintenance costs, when used in VRF IV systems
- » Increased indoor air quality with high efficiency filter options and ventilation connection kit
- » Very flexible with 18 different possible airflow patterns, ensuring ideal air distribution to maximize comfort and efficiency
- » Compact design to allow for installation in small ceiling voids
- » Sound pressure levels as low as 27 db(A)

The built-in occupancy sensor has two main functions: save energy and optimize occupancy comfort. In order to save energy, the function of the occupancy sensor can be used to automatically set back the air temperature and also lower the fan speed if no people are present in the room.

Together with the occupancy sensor, the air-temperature sensor and the built-in surface temperature sensor are



used to maintain an even and comfortable temperature distribution from floor to ceiling in the room. This is done by automatically adjusting the supplied airflow rate and the individual position of each of the four supply air louvers in the unit, thus maintaining the required comfortable space environment.

In order to further increase efficiency and reduce maintenance costs, the *Round Flow Sensing Cassette* can be equipped with an optional self-cleaning filter panel that performs automatic air-filter cleaning up to once a day. Dust is deposited into a collection box during the self-cleaning process. When indicated with light on the unit and on the controller display, the dust collection box in the unit can easily and quickly be emptied with a standard vacuum cleaner.

#### Applications

- » Retail
- » Schools
- » Offices
- » Restaurants

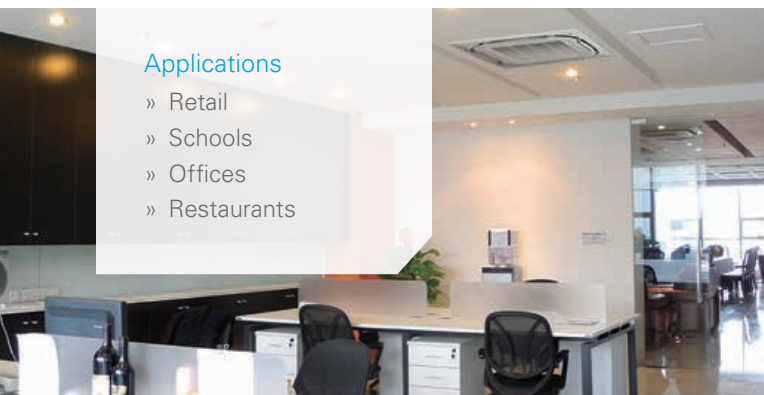

#### 4-way flow vs. Round Flow

*Round Flow* Ceiling Mounted Cassette type offers 360° airflow with improved temperature distribution.

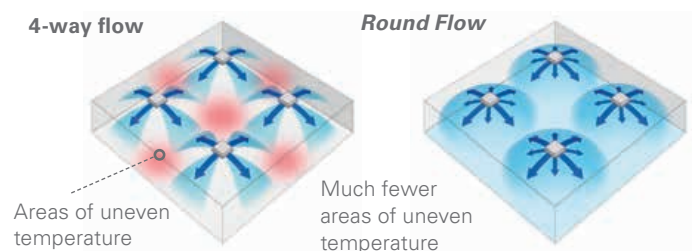



Advanced design for comfort and efficiency

**Heat Exchanger Design**

Optimized for part load operation — great enhancement to seasonal energy efficiency

**Occupancy and Surface Temperature Sensors**

Enables additional energy savings and increased comfort

**Optional Self-Cleaning Filter Panel**

Provides optimum efficiency, airflow and reduced maintenance

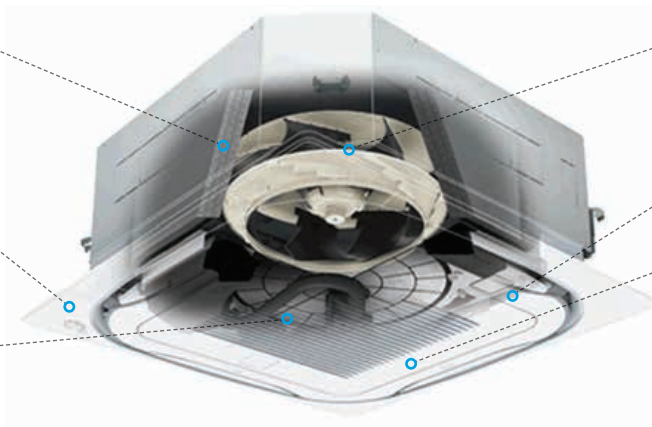

**DC Fan Motor**

Very efficient — enables fan auto logic based on  $\Delta T$  set point

**DC Drain Pump**

Low power consumption

**Decoration Panel**

- » Efficient due to large air discharge outlets
- » Unique 360° airflow distribution
- » 4 individually controlled louvers enables optimized comfort in the space
- » Possibility to close 1, 2 or 3 louvers adds flexibility

Automatic air-direction control

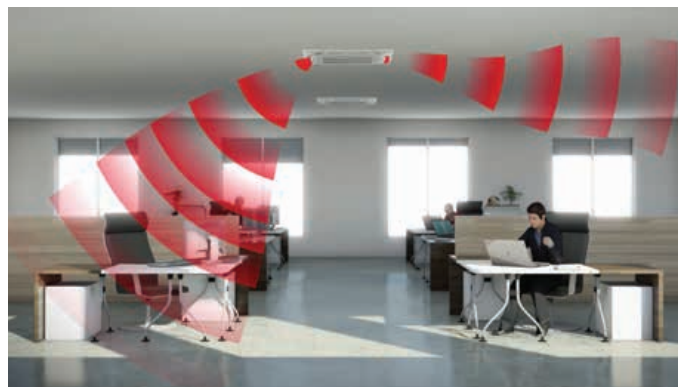

Air flow from the indoor unit is automatically adjusted to always maintain a comfortable environment — even when occupancy changes.

Dual infrared sensors

Sensors detect the presence of people and surface temperature to provide comfortable air-conditioning and energy savings.

**Infrared presence sensor**

The sensor detects human presence, and energy saving control can be performed when no people are detected.

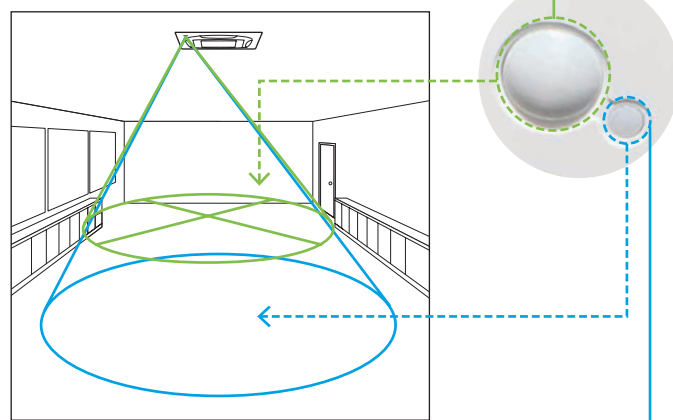

**Infrared surface sensor**

The sensor detects the surface temperature and automatically adjusts operation of the indoor unit to reduce the temperature difference between the ceiling and the floor.

# FXFQ\_AAVJU (cont.)

## Round Flow Sensing Cassette



Condensate Pump as Standard



Outside Air Integration Possible



Filter Included



Optional Auto Cleaning Filter



Surface & Occupancy Sensor Kit as Standard

Automatic air filter cleaning (optional)

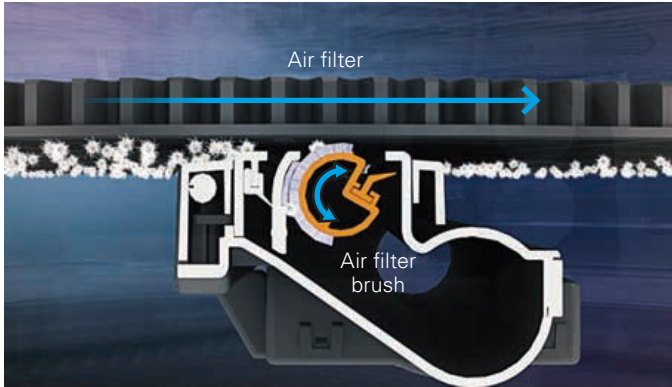

At the programmed time, the air filter rotates while the air filter brush turns back and forth to brush the filter.

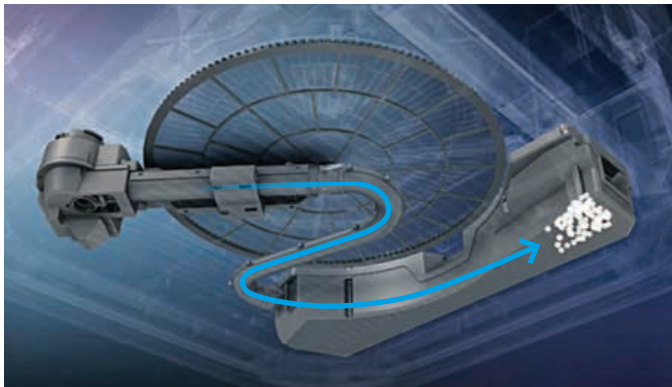

Dust from the air filter brush is deposited into the dust collection container during the fully automatic self-cleaning process.

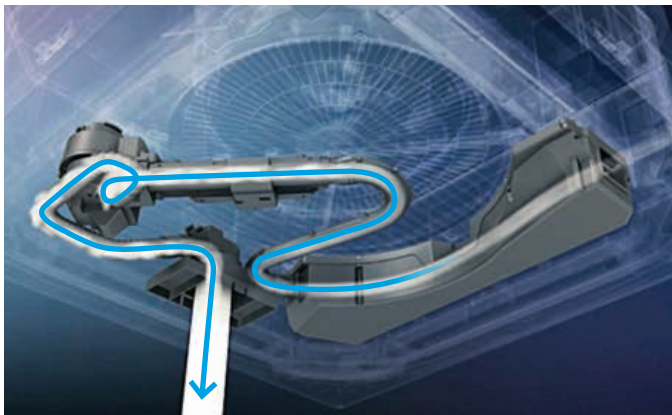

When indicated, the dust container in the unit is easily emptied with a standard vacuum cleaner.



FXFA_AAVJU SPECIFICATIONS		0.60 TON	0.75 TON	1 TON	1.25 TON	1.5 TON	2 TON	2.5 TON	3 TON	4 TON	4.5 TON	
Model Name		FXFQ07AAVJU	FXFQ09AAVJU	FXFQ12AAVJU	FXFQ15AAVJU	FXFQ18AAVJU	FXFQ24AAVJU	FXFQ30AAVJU	FXFQ36AAVJU	FXFQ48AAVJU	FXFQ54AAVJU	
Power Supply	(V/ph/Hz)	208-230/1/60										
Rated Cooling Capacity	BTU/h	7,200	9,500	12,000	14,400	18,000	23,000	30,000	36,000	48,000	54,000	
Rated Heating Capacity	BTU/h	8,500	10,500	13,500	17,000	20,000	27,000	34,000	40,000	48,000	60,000	
Refrigerant		R-410A										
Refrigerant Control		Electronic Expansion Valve										
Airflow Rate H/M/L	CFM	420/406/353	441/406/353	441/406/353	512/459/388	742/618/477	777/618/477	1,112/918/671	1,165/918/671	1,218/971/742	1,531/1006/741	
Unit Weight	lbs	42				48			63			
Unit Height	in.	9-11/16					11-5/16					
Unit Width	in.	33-1/16										
Unit Depth	in.	33-1/16										
Sound Pressure H/M/L	dB(A)	30/28.5/27			31/29/27	35.5/32/28	36/32/28	43.5/38/32	44/38/32	45/40/35	47/41/36	
Unit Condensate Connection	in. O.D.	1-1/4										
Condensate Pump Lift	in.	33-1/2										
Pipe Connections	Gas	in. 1/2 (Flare)					in. 5/8 (Flare)					
	Liquid	in. 1/4 (Flare)					in. 3/8 (Flare)					
External Finish		Galvanized Steel Plate										
Protection Devices		Fuse/Breaker										
		Fan Motor Thermal Protector										
Recommended Fuse/Breaker	A	15										
Standard Filter Type		Mold-Resistant Resin Net										

**Nominal Conditions:**

**Cooling Mode**

Indoor: 80 °F DB / 67 °F WB  
 Outdoor: 95 °F DB  
 Pipe Length: 25 ft.  
 Level Difference: 0 ft.

**Heating Mode**

Indoor: 70 °F DB  
 Outdoor: 47 °F DB / 43 °F WB  
 Pipe Length: 25 ft.  
 Level Difference: 0 ft.

**Note:** Specifications are subject to change without notice.

**FXFA\_AAVJU ACCESSORIES WITH:**

Accessory	Item #	Self-Cleaning Filter Panel (BYCQ54EEGFU)	Standard Sensing Decoration Panel (BYCQ54EEFU)
Navigation Remote Controller	BRC1NRV71/72	Yes <sup>1</sup>	Yes <sup>1</sup>
Navigation Remote Controller	BRC1E52A7	Yes <sup>2</sup>	Yes <sup>2</sup>
Remote Sensor Kit	KRCS01-4B	Yes	Yes
Outside Air Intake Kit	KAF555D160	Available	Yes
Long-Life Replacement Air Filter			
Panel Spacer	KDBP55H160FA	Yes	Yes

<sup>1</sup> No sensing functions available

<sup>2</sup> Optional face plates available to provide a more intuitive user interface and disable specific functions

**OUTDOOR / CONDENSING UNIT COMPATIBILITY**

Outdoor Condensing Unit	FXFQ-AAVJU with:	
	Self-Cleaning Filter Panel (BYCQ54EEGFU)	Standard Sensing Decoration Panel (BYCQ54EEFU)
VRV IV X, VRV EMERION	Yes	Yes
VRV LIFE, VRV IV S	Yes	Yes
SkyAir	Yes	Yes

**FXFA INSTALLATION SPACE**

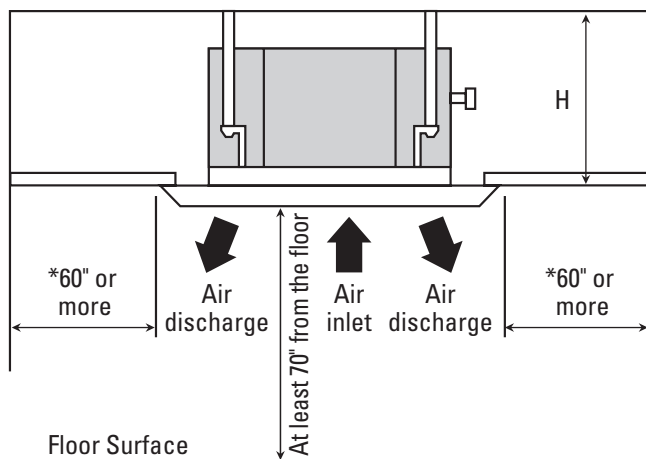

MODEL	HEIGHT
FXFQ07-24AAVJU	11"
FXFQ30-54AAVJU	12" or more

\* Leave 7 7/8" or more space on sides where the air outlet is closed.

# FXUQ\_PAVJU

## 4-Way Ceiling-Suspended Cassette



Condensate Pump  
as Standard



Filter  
Included



Optional Surface &  
Occupancy Sensor Kit

### Slim, Stylish, Flexible

The unique 4-way ceiling-suspended cassette is an ideal solution for rooms without a false ceiling, or minimal space above a false ceiling, where adaptive comfort control is preferred.

The optional Sensor Kit (occupancy and surface temperature) together with air temperature sensor and advanced control functions enables the unit to provide an exceptional comfort level, energy efficiency, and flexibility.

### Features and Benefits

- » Very low unit height of under 8" makes it an ideal solution for school, shops, restaurants and offices with no or low false ceilings
- » Optional Sensor Kit enables input from three room sensors to provide optimized occupant comfort and efficiency
- » Stylish unit blends easily with any interior, as the air louvers close entirely when not in operation
- » Energy efficient fan motor
- » Individual air louver control — one or more louvers can be easily closed via the remote controller when required
- » Ideal for both new and existing buildings
- » Can also be mounted partially recessed in a false ceiling
- » Same appearance and size for all capacity models
- » Standard drain pump with 19.5" lift



BRC1NRV71/72  
(option)



AZAI6WSPDKC  
(option)



AZAI6WSCDKA  
(option)



BRC1H71W  
(option)

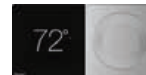

DTST-CWBSA-NI-B  
(option)



DTST-TOU-A  
(option)

### Flexible Airflow Pattern

The four individually controlled air louvers in the unit enables comfortable space environment in a variety of different room layouts.

Air from each louver can be set to exhaust in 5 different angles between 0 and 60 degrees, or set to auto-swing.

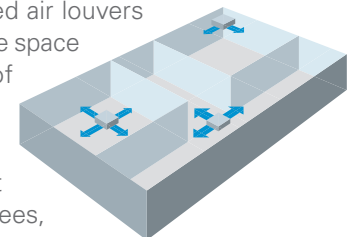

#### Airflow Angles

**Auto Swing:** Wide discharge angle: 0° to 60°

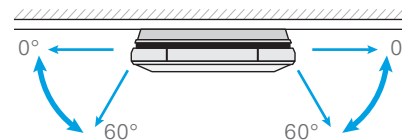

**Fixed angles:** 5 levels

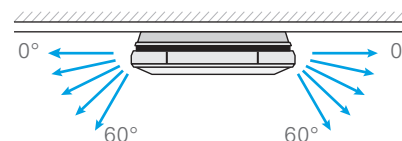

### Applications

- » Retail
- » Schools
- » Offices
- » Restaurants

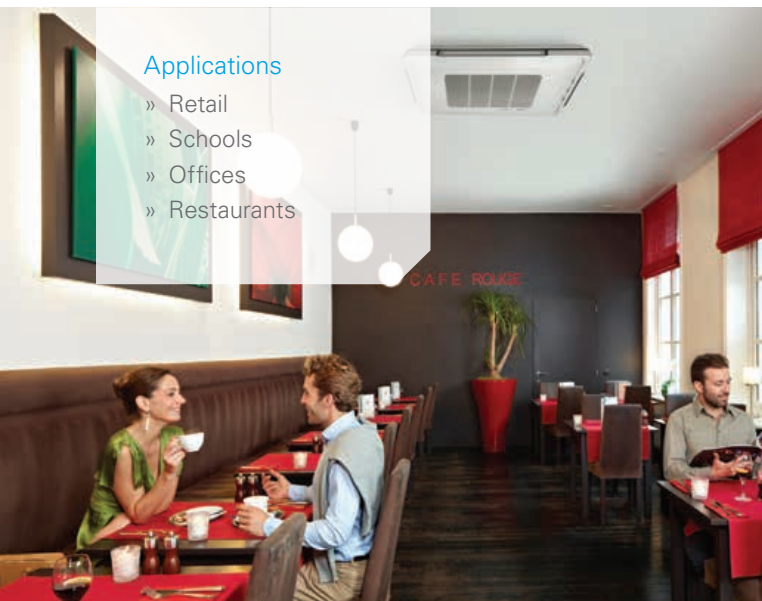

FXUQ_PAVJU SPECIFICATIONS		1.5 TON	2 TON	2.5 TON	3 TON
Model Name		FXUQ18PAVJU	FXUQ24PAVJU	FXUQ30PAVJU	FXUQ36PAVJU
Power Supply	(V/ph/Hz)	208-230/1/60			
Rated Cooling Capacity	BTU/h	18,000	24,000	30,000	36,000
Rated Heating Capacity	BTU/h	20,000	27,000	34,000	40,000
Airflow Rate (H/M/L)	CFM	795/689/565		1095/918/742	
Weight	lbs.	58			60
Height	in.	7-13/16			
Width	in.	37 3/8			
Depth	in.	37 3/8			
Sound Pressure (H/M/L)	dB(A)	40/38/36		47/44/40	
Condensate Pump Lift	in.	19.5			
Condensate Pipe Connection	in. O.D.	VP20			
Pipe Connections	Gas	in.	1/2 (Flare)	5/8 (Flare)	5/8 (Flare)
	Liquid	in.	1/4 (Flare)	3/8 (Flare)	3/8 (Flare)
Refrigerant		R-410A			
Refrigerant Control		Electronic Expansion Valve			
Maximum Overcurrent Protective Device	A	15			
Minimum Circuit Amps	A	0.6		1.4	
Protection Devices		Fuse and Fan Motor Thermal Protector			
External Finish		White Casing			
Standard Filter Type		Resin Net (with Mold Resister)			

**Nominal Conditions:**

**Cooling Mode**

Indoor: 80°F DB / 67°F WB  
 Outdoor: 95°F DB  
 Pipe Length: 25 ft.  
 Level Difference: 0 ft.

**Heating Mode**

Indoor: 70°F DB  
 Outdoor: 47°F DB / 43°F WB  
 Pipe Length: 25 ft.  
 Level Difference: 0 ft.

**Note:** Specifications are subject to change without notice.

FXUQ_PAVJU ACCESSORIES				
Model Name	FXUQ18PAVJU	FXUQ24PAVJU	FXUQ30PAVJU	FXUQ36PAVJU
Sealing Member of Air Discharge Outlet			KDBHP49B140	
Decoration Panel for Air Discharge			KDBTP49B140	
Replacement Long-Life Filter			KAF5511D160	
Navigation Remote Controller			BRC1NRV71/72	
Sensor Kit <sup>2</sup>			BRE49B2F	
Madoka Remote Controller			BRC1H71W	
Button Sensor Kit			KRCSH2018-02	
Daikin ONE+ Smart Thermostat			DTST-CWBSA-NI-B	
DKN Plus Interface			AZA16WSPDKC	
Daikin ONE Touch			DTST-TOU-A	
Group Control Adaptor Printed Circuit Board <sup>1</sup>			KRP4A74	
Installation Box for Adaptor PCB			KRP1BA97	
Remote Sensor <sup>2</sup>			KRCS01-6B	

<sup>1</sup> Installation box for Adaptor PCB (KRP1BA97) is necessary. <sup>2</sup> Remote Sensor can only be installed when Sensor Kit is not installed.

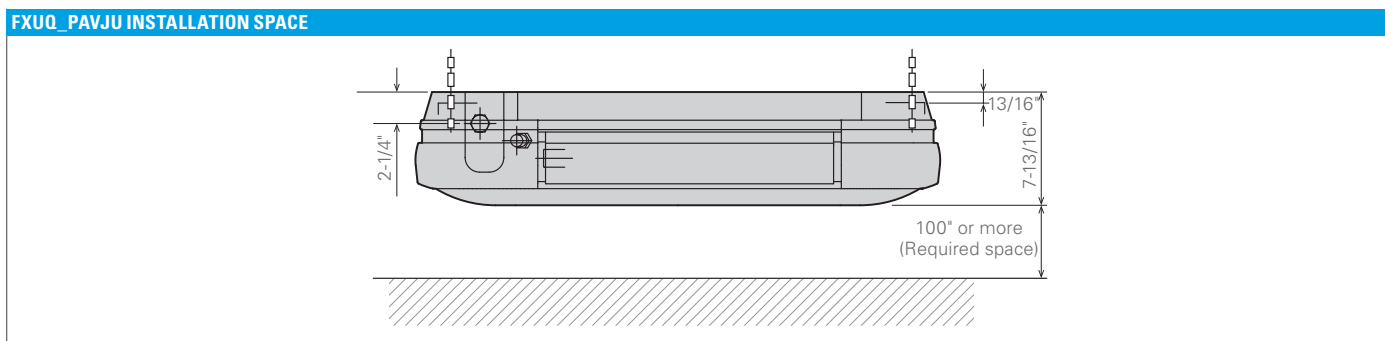

Automatic air-direction control

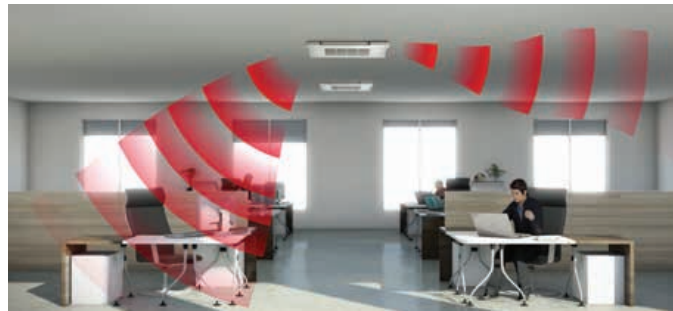

Air-flow from the indoor unit is automatically adjusted to always maintain a comfortable environment — even when occupancy changes.

# FXZQ\_TBVJU

## VISTA 2 x 2 Cassette Unit for VRV



Condensate Pump  
as Standard



Outside Air  
Integration Possible



Filter  
Included

### Designer Comfort

VISTA is a remarkable blend of iconic design and engineering excellence with an elegant white or a silver and white finish. Fitting within the ceiling grid, VISTA is stylish, low profile, and compact. Energy efficiency and comfort can be enhanced through the combined use of optional floor and presence sensors. It is also possible to close individual louvers via the wired remote control for personalized comfort.

### Features and Benefits

- » New 0.5 ton (5,800 Btu/h) size.
- » Seamless integration in standard architectural ceiling tiles, eliminating any overlap of adjacent tiles.
- » Energy efficient operation thanks to specially developed small tube heat exchanger and two optional intelligent sensors.
- » The use of a high efficiency DC fan motor reduces operational power input up to 48% compared to the previous generation.
- » Provides high degree of control for auxiliary heating devices, with independently configurable on/off temperature values.
- » Direct integration of fresh air through a factory knock out.



BRC1NRV71/72  
(option)



AZAI6WSCDKA  
(option)



BRC4C82  
(option)



BRC1H71W  
(option)



AZAI6WSPDKC  
(option)

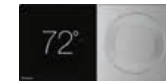

DTST-CWBSA-NI-B  
(option)



DTST-TOU-A  
(option)

### Flexible Airflow Patterns

The four air louvers in the unit enables comfortable space environment in many different room layouts.

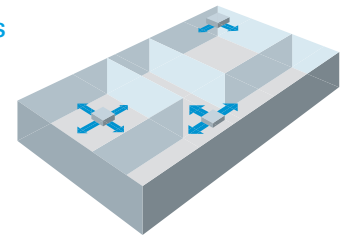

#### Airflow Angles

**Auto Swing:** Wide discharge angle: 0° to 60°

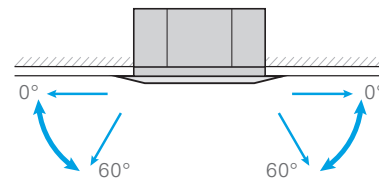

**Fixed Angles:** 5 Levels

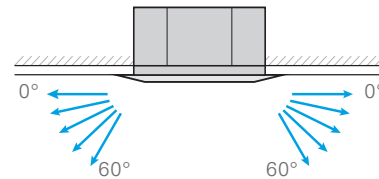

Angles can be also set on site to prevent drafts (0°-35°) or soiling of the ceiling (25°-60°), other than standard setting (0°-60°).

#### Applications

- » Retail
- » Schools
- » Offices

SPECIFICATIONS		0.5 TON	0.6 TON	0.75 TON	1 TON	1.25 TON	1.5 TON
Model Name		FXZQ05TBVJU	FXZQ07TBVJU	FXZQ09TBVJU	FXZQ12TBVJU	FXZQ15TBVJU	FXZQ18TBVJU
Capacity Index		5.8	7.5	9.5	12	15	18
Power Supply	V/ph/Hz	208/230VAC, 60Hz, 1 phase					
Nominal Cooling Capacity*1	Btu/h (kW)	5,800 (1.7)	7,500 (2.2)	9,500 (2.8)	12,000 (3.5)	15,000 (4.5)	18,000 (5.3)
Nominal Heating Capacity*2	Btu/h (kW)	6,500 (1.9)	8,500 (2.5)	10,500 (3.1)	13,500 (4.0)	17,000 (5.0)	20,000 (5.9)
Fan	Type	Turbo Fan					
	Motor Output	W					
	Air Flow Rate (H/M/L)	CFM					
	Drive Type	DC Direct Drive					
Dimensions - Unit Body (H x W x D)	in. (mm)	10-1/4 x 22-5/8 x 22-5/8 (260x575x575)					
Dimensions - Decoration Panel (H x W x D)	in. (mm)	1-13/16 x 24-7/16 x 24-7/16 (46x620x620)					
Weight (net)	lb. (kg)	40.4 (18.3)			42.6 (19.3)		47 (21.3)
Condensate Pump Lift	in. (mm)	24-15/16 (630)					
Sound Pressure Level (H/M/L speed)	dB(A)	32 / 29.5 / 25.5		33 / 30 / 29.5	33.5 / 30 / 26	37 / 32 / 28	43 / 40 / 33
Pipe Connections	Liquid	in. 1/4 (Flare)					
	Gas	in. 1/2 (Flare)					
	Condensate Drain	in. VP20					
Refrigerant Control	Electronic Expansion Valve						
Maximum Overcurrent Protection Device	A	15					
Minimum Circuit Ampacity	A	0.3			0.4		0.6
Decoration Panel - White	BYFQ60C3W1W						
Decoration Panel - Silver/White	BYFQ60C3W1S						

**Notes:** \*1 Nominal cooling capacities are based on the following conditions: 80°F DB / 67°F WB (26.7°C DB / 19.4°C WB) return air temperature; 95°F DB (35°C DB) outdoor temperature; 25 ft. (7.6 m) equivalent refrigerant piping.

\*2 Nominal heating capacities are based on the following conditions: 70°F DB (21.1°C DB) return air temperature; 47°F DB / 43°F WB (8.3°C DB / 6.1°C WB) outdoor temperature; 25 ft. (7.6 m) equivalent refrigerant piping.

#### FXZQ\_TB VJU ACCESSORIES

Model Name	FXZQ05TBVJU	FXZQ07TBVJU	FXZQ09TBVJU	FXZQ12TBVJU	FXZQ15TBVJU	FXZQ18TBVJU
Navigation Remote Controller*				BRC1NRV71/72		
DKN Cloud Wi-Fi Adaptor				AZA16WSCDKA		
Madoka Remote Controller				BRC1H71W		
Button Sensor Kit				KRCSH2018-02		
Daikin ONE+ Smart Thermostat				DTST-CWBSA-NI-B		
DKN Plus Interface				AZA16WSPDKC		
Daikin ONE Touch				DTST-TOU-A		
Infrared Remote Controller - White**				BRC082A42W		
Infrared Remote Controller - Silver**				BRC082A42S		
Space and Presence Sensor Kit - White**				BRYQ60AAW		
VISTA Decoration Panel - White				BYFQ60C3W2W		
Legacy MVJU9-style Decoration Panel				BYFQ60B3W1		
Remote Sensor Kit				KRCS01-6B		
Wiring Adaptor PCB (interface with aux heater, humidifier, OA damper/fan)				KRC1C75		
Long-Life Replacement Filter				KAFQ441BA60		
Sealing Member of Air Discharge Kit				BDBHQ44C60		
Fresh Air Intake Kit				KDDQ44XA60		

\*Optional face plates to provide a more intuitive user interface and disable specific functions

\*\*Not compatible with the legacy-style decoration panel

#### FXZQ\_TB VJU INSTALLATION SPACE

MODEL	HEIGHT
FXZQ05-18TBVJU	11.75" or more

\*Leave 7-7/8" or more space on sides where the air outlet is closed.

# FXEQ\_PVJU

## Ceiling-Mounted Cassette (Single Flow)



Condensate Pump as Standard



Outside Air Integration Possible



Filter Included

### Slim and Compact Design for Installation Flexibility

#### Features and Benefits

- » The main body of the unit is optimized to be a compact design. Only 7-7/8" in height and a width of 18-1/2" making it possible to use this style of indoor unit in the tightest of spaces.

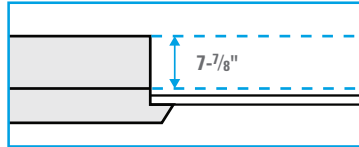

- » The innovative discharge air louver design forces air in heating mode to ground level to improve the overall space heating effect of the indoor unit.

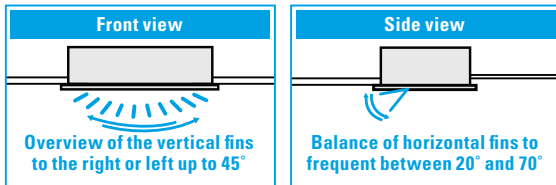

- » The unit is equipped with both horizontal and vertical louvers that can be freely adjusted with the remote controller providing a capability to optimize the airflow and throw to suit your room design.
- » The utilization of both a DC-style Fan Motor and integrated Condensate Pump allow for improvements in energy consumption as well as lower operating sound levels than other styles of indoor units.
- » This Indoor unit can be set to 5 predetermined fan speeds using the BRC1NRV71/72 wired remote controller, which allows for optimum and comfortable airflow.

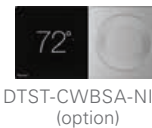
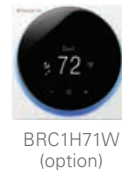
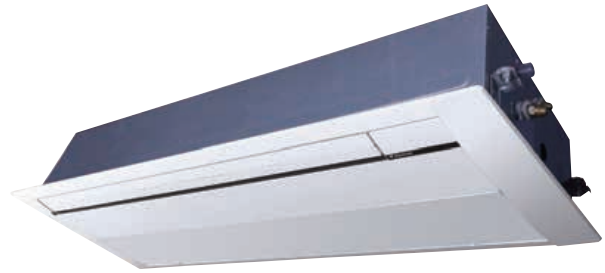

- » A Ventilation Air knock-out is provided to allow up to 15% of the rated airflow through the unit to be pretreated outside air.

- » The innovative "smooth finish" decoration panel design helps to minimize dust and dirt build-up and facilitates easier cleaning.



- » The Indoor Unit is equipped with a factory installed condensate pump with a lift capacity of up to 33-7/16" (measured from the bottom of the unit).

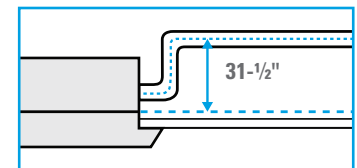

- » The units are equipped with customizable auxiliary heat control settings to facilitate the On/Off control of an external auxiliary heat solution.

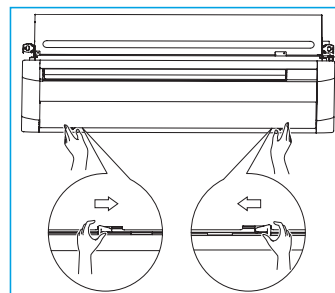

- » For ease of service and maintenance activities, it is possible to access the main components of the unit by only removing the decoration panel.

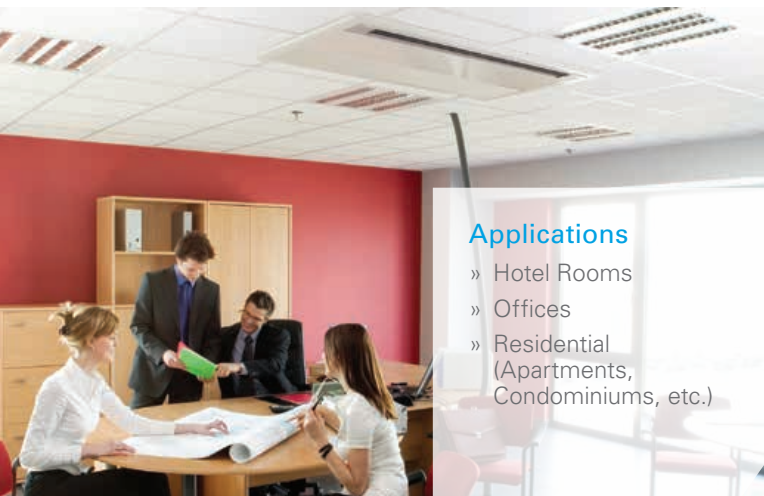

#### Applications

- » Hotel Rooms
- » Offices
- » Residential (Apartments, Condominiums, etc.)



FXEQ_PVJU SPECIFICATIONS			0.6 TON	0.75 TON	1.0 TON	1.25 TON	1.5 TON	2 TON	
Model			FXEQ07PVJU	FXEQ09PVJU	FXEQ12PVJU	FXEQ15PVJU	FXEQ18PVJU	FXEQ24PVJU	
Power Supply			1 phase 60Hz 208/230V						
Cooling capacity	*1,*3	Btu/h	7500	9500	12000	15000	18000	24000	
Heating capacity	*2,*3	Btu/h	8500	10500	13500	17000	20000	27000	
Electrical	Min. circuit amps (MCA)	A	0.3	0.4	0.4	0.5	0.5	0.7	
	Max. overcurrent protection (MOP)	A	15	15	15	15	15	15	
Casing/color			Galvanized steel plate						
Dimensions: (H x W x D)			7-7/8 x 18-1/2 x 33-1-1/16				7-7/8 x 18-1/2 x 48-13/16		
Fan	Type		Sirocco fan						
	Air flow rate (Dry coil)	Cooling (H/HM/M/ML/L)	CFM	212/191/173/155/141	244/226/205/187/170	283/265/247/223/194	346/311/276/247/219	441/403/367/336/307	530/481/431/389/346
	Drive		Direct drive						
Sound pressure level	Cooling (H/HM/M/ML/L)	dBA	30/29/28/27/26	32/31/30/29/28	35/34/33/32/30	38/37/35/33/31	38/37/35/33/31	43/41/39/37/35	
Weight		lbs.	38			40		51	
Piping connections	Liquid	in.	ø 1/4 (flare connection)					ø 3/8 (flare connection)	
	Gas	in.	ø 1/2 (flare connection)					ø 5/8 (flare connection)	
	Drain	in.	PVC26 (O.D. 1-1/32 x I.D. 13/16)						
Drain pump lift		in.	25						
Refrigerant control			Electronic expansion valve						
Connectable outdoor unit			R-410A VRV series						
Decoration panel (required option)	Model		BYEP40AW1				BYEP63AW1		
	Color		Fresh White						
	Dimensions (H x W x D)		3-3/16 x 21-5/8 x 37-13/32				3-3/16 x 21-5/8 x 53-5/32		
	Air filter		Resin net (with mold resistant)						
	Weight		17.6			22			

**Notes:** \*1 Nominal cooling capacities are based on the following conditions: return air temperature: 80.0°F DB (26.7°C DB), 67.0°F WB (19.4°C WB), outdoor temperature: 95.0°F DB (35.0°C DB) equivalent ref. piping: 25ft. (7.6m) (Horizontal)

\*2 Nominal heating capacities are based on the following conditions: return air temperature: 70.0°F DB (21.1°C DB), outdoor temperature: 47.0°F DB (8.3°C DB), 43.0°F DB (6.1°C WB) equivalent ref. piping: 25ft. (7.6m) (Horizontal)

\*3 Capacities are net, including a deduction for cooling (an addition for heating) for indoor fan motor heat.

#### FXEQ\_PVJU ACCESSORIES

Model	FXEQ07PVJU	FXEQ09PVJU	FXEQ12PVJU	FXEQ15PVJU	FXEQ18PVJU	FXEQ24PVJU
Decoration panel	BYEP40AW1					BYEP63AW1
Navigation Remote Controller				BRC1NRV71/72		
Madoka Remote Controller				BRC1H71W		
Button Sensor Kit				KRCSH2018-02		
Daikin ONE+ Smart Thermostat				DTST-CW/BSA-NI-B		
DKN Plus Interface				AZAI6WSPDKC		
Daikin ONE Touch				DTST-TOU-A		
Remote sensor				KRCS01-4B		
Wiring adaptor printed circuit board	2				KRP1C75	
Group control adaptor printed circuit board	2				KRP4A74	
Adaptor mounting box				KRP1B101		

**Note:** \*1 Electrical box (No.5-1/6-1) is required for controller (No. 5/6) \*2 Adaptor mounting box (No.12) is necessary.

#### FXEQ\_PVJU INSTALLATION SPACE

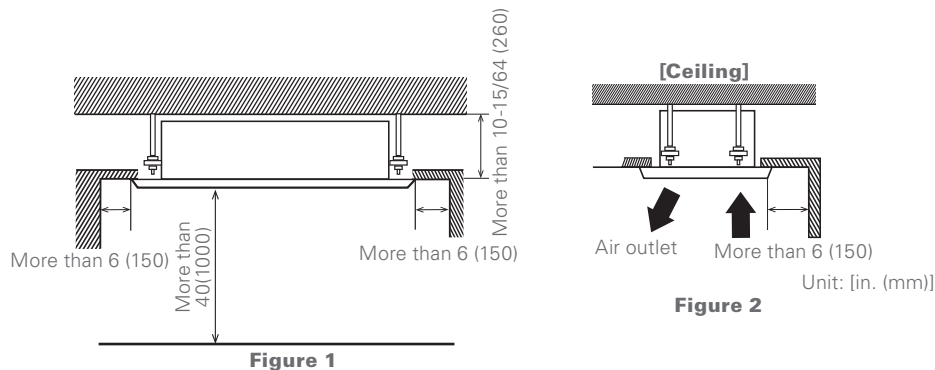

# FXHQ\_MVJU

## Ceiling-Suspended Unit



Optional  
Condensate Pump

Filter  
Included

### Slim, Efficient, Quiet, Easy to Maintain

With its slim, elegant design, the FXHQ ceiling-suspended unit is a great fit for any light commercial space. Wide air openings provide a comfortable airflow and an innovative stream fan ensures quiet operation, making it ideal for retail stores, restaurants, classrooms and conference rooms.

### Features and Benefits

- » One of our slimmest indoor units (less than 8") fits within any interior design
- » Wide air discharge outlet distributes a comfortable airflow throughout the entire space with throw of up to 25 ft.
- » Innovative stream fan technology keeps sound pressure levels low
- » Smooth flat louver design makes cleaning simple
- » Long-life filter is standard
- » Models range from 12 MBH to 36 MBH

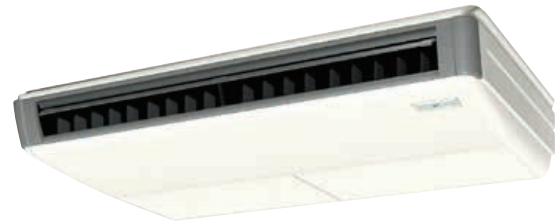

BRC1NRV71/72  
(option)



AZAI6WSCDKA  
(option)



BRC4C82  
(option)



BRC1H71W  
(option)



AZAI6WSPDKC  
(option)

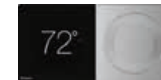

DTST-CWBSA-NI-B  
(option)



DTST-TOU-A  
(option)

### Quiet Stream Fan (side view)

Uses the quiet stream fan and many more advanced technologies.

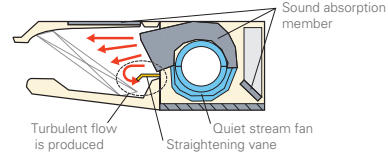

### Applications

- » Retail/shops
- » Offices
- » Restaurants



FXHQ_MVJU SPECIFICATIONS		1 TON		2 TON		3 TON	
Model Name		FXHQ12MVJU		FXHQ24MVJU		FXHQ36MVJU	
Power Supply	V/ph/Hz	208-230/1/60					
Rated Cooling Capacity	BTU/h	12,000		24,000		36,000	
Rated Heating Capacity	BTU/h	13,500		27,000		40,000	
Airflow Rate (H/L)	CFM	410/340		710/600		830/670	
Weight	lbs.	55		80		90	
Height	in.	7-11/16					
Width	in.	37-13/16		55-1/8		62-5/8	
Depth	in.	26-3/4					
Sound Pressure (H/L)	dB(A)	42/33		44/36		46/41	
Condensate Pipe Connection	in. O.D.	1					
Pipe Connections	Gas	in.	1/2 (Flare)		5/8 (Flare)		
	Liquid	in.	1/4 (Flare)		3/8 (Flare)		
Refrigerant		R-410A					
Refrigerant Control		Electronic Expansion Valve					
Maximum Overcurrent Protective Device	A	15					
Minimum Circuit Amps	A	0.8		1.0		1.4	
Protection Devices		Fuse and Fan Motor Thermal Protector					
External Finish		White Casing					
Standard Filter Type		Resin Net (with Mold Resistant)					

**Nominal Conditions:****Cooling Mode**

Indoor: 80°F DB / 67°F WB  
 Outdoor: 95°F DB  
 Pipe Length: 25 ft.  
 Level Difference: 0 ft.

**Heating Mode**

Indoor: 70°F DB  
 Outdoor: 47°F DB / 43°F WB  
 Pipe Length: 25 ft.  
 Level Difference: 0 ft.

**Note:** Specifications are subject to change without notice.

FXHQ_MVJU ACCESSORIES			
Model Name	FXHQ12MVJU	FXHQ24MVJU	FXHQ36MVJU
Navigation Remote Controller*		BRC1NRV71/72	
DKN Cloud Wi-Fi Adaptor		AZAI6WSCDKA	
Madoka Remote Controller		BRC1H71W	
Button Sensor Kit		KRCSH2018-02	
Daikin ONE+ Smart Thermostat		DTST-CWBSA-NI-B	
DKN Plus Interface		AZAI6WSPDKC	
Daikin ONE Touch		DTST-TOU-A	
Wireless Remote Controller		BRC7E83	
Remote Sensor Kit		KRCS01-1B	
Wiring Adaptor PCB (interface with aux/primary heater, humidifier, OA damper/fan)		KRP1C74	
Group Control Adaptor PCB (connects to external BMS)		KRP4A72	
Replacement long-life filter	KAFJ501D56	KAFJ501D112	KAFJ501D160
Condensate Pump		DACA-CP3-1	

\* Optional face plates available to provide a more intuitive user interface and disable specific functions

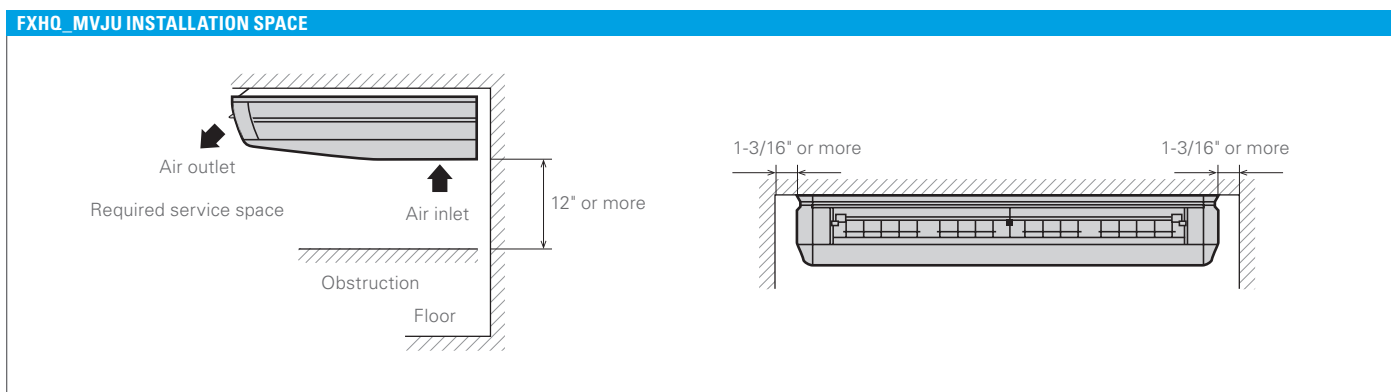

# FXAQ\_PVJU

## Wall-Mounted Unit



Optional  
Condensate Pump



Filter  
Included

### Stylish, Compact, Convenient, Comfortable

Daikin's wall-mounted units are ideal for cooling or heating smaller zones such as stores, offices, and restaurants. The compact, stylish design lets the unit blend discreetly into any interior design, and airflow can be supplied in any of five different directions and easily programmed via remote control.



### Features and Benefits

- » Auto-swing mechanism ensures efficient air distribution via louvers that automatically close when the unit is turned off
- » Wide air discharge outlet distributes a comfortable airflow throughout the entire space
- » Horizontal louvers and front panel can be easily removed for cleaning
- » Drain pipe can be easily hidden from sight
- » Models range from 7.5 MBH to 24 MBH



BRC1NRV71/72  
(option)



AZAI6WSCDKA  
(option)



BRC4C82  
(option)



BRC1H71W  
(option)



AZAI6WSPDKC  
(option)

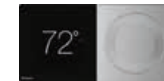

DTST-CWBSA-NI-B  
(option)



DTST-TOU-A  
(option)

### Applications

- » Retail
- » Restaurants
- » Offices
- » Hotels
- » Multi-family residences



FXAQ_PVJU SPECIFICATIONS		0.6 TON	0.75 TON	1 TON	1.5 TON	2 TON
Model Name		FXAQ07PVJU	FXAQ09PVJU	FXAQ12PVJU	FXAQ18PVJU	FXAQ24PVJU
Power Supply	V/ph/Hz	208-230/1/60				
Rated Cooling Capacity	BTU/h	7,500	9,500	12,000	18,000	24,000
Rated Heating Capacity	BTU/h	8,500	10,500	13,500	20,000	27,000
Airflow Rate (H/L)	CFM	260/160	280/175	290/180	500/400	635/470
Weight	lbs.	26				31
Height	in.	11-3/8				
Width	in.	31-1/4			41-3/8	
Depth	in.	9				
Sound Pressure (H/L)	dB(A)	36/31	37/31	38/31	43/37	47/41
Condensate Pipe Connection	in. O.D.	11/16				
Pipe Connections	Gas	in.			1/2 (Flare)	
	Liquid	in.			1/4 (Flare)	
Refrigerant		R-410A				
Refrigerant Control		Electronic Expansion Valve				
Maximum Overcurrent Protective Device	A	15				
Minimum Circuit Amps	A	0.4			0.5	0.6
Protection Devices		Fuse and Fan Motor Thermal Protector				
External Finish		White Casing				
Standard Filter Type		Resin Net (washable)				

**Nominal Conditions:**

**Cooling Mode**

Indoor: 80°F DB / 67°F WB  
 Outdoor: 95°F DB  
 Pipe Length: 25 ft.  
 Level Difference: 0 ft.

**Heating Mode**

Indoor: 70°F DB  
 Outdoor: 47°F DB / 43°F WB  
 Pipe Length: 25 ft.  
 Level Difference: 0 ft.

**Note:** Specifications are subject to change without notice.

**FXAQ\_PVJU ACCESSORIES**

Model Name	FXAQ07PVJU	FXAQ09PVJU	FXAQ12PVJU	FXAQ18PVJU	FXAQ24PVJU
Navigation Remote Controller*			BRC1NRV71/72		
DKN Cloud Wi-Fi Adaptor			AZA16WSDKA		
Madoka Remote Controller			BRC1H71W		
Button Sensor Kit			KRCSH2018-02		
Daikin ONE+ Smart Thermostat			DTST-CWBSA-NI-B		
DKN Plus Interface			AZA16WSPDKC		
Daikin ONE Touch			DTST-TOU-A		
Wireless Remote Controller			BRC7E818		
Remote Sensor Kit			KRCS01-1B		
Group Control Adaptor PCB (Connects to external BMS)			KRP4A71		
Condensate Pump			DACA-CP1-1		

\* Optional face plates available to provide a more intuitive user interface and disable specific functions

**FXAQ\_PVJU INSTALLATION SPACE**

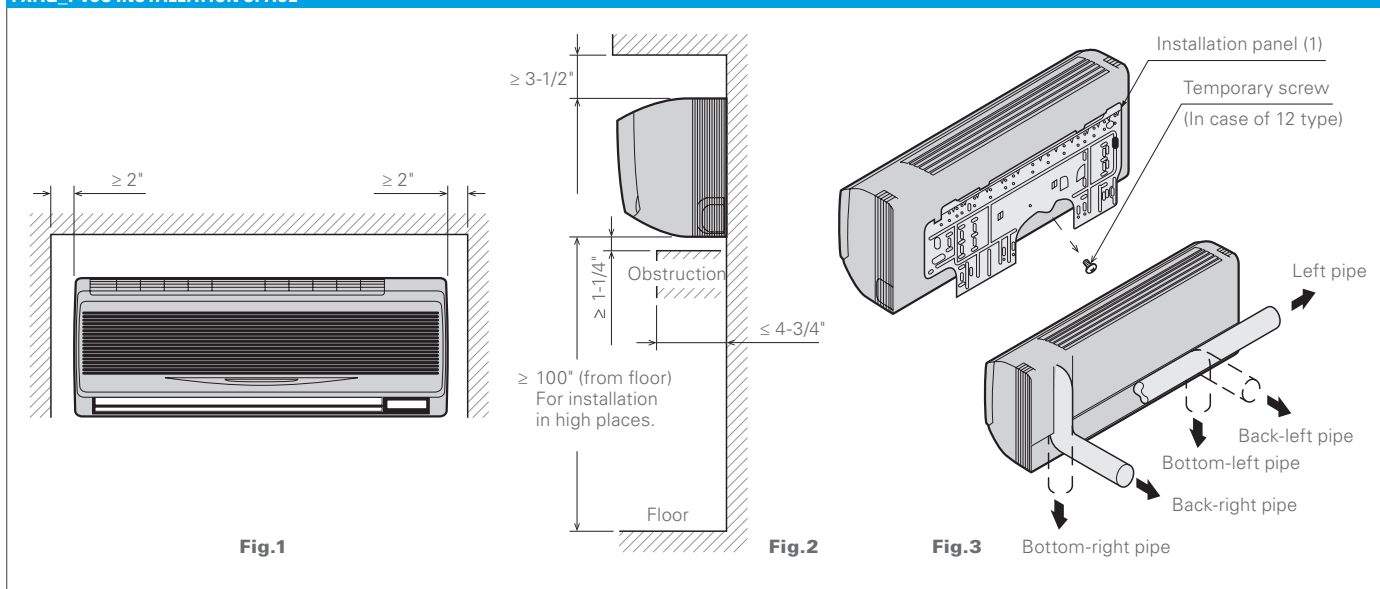

**Fig.1**

**Fig.2**

**Fig.3**

# FXLO\_MVJU9

## Floor-Standing Unit



Filter  
Included

### Versatile, Logical, Durable, Quiet

The ideal way to save space, our floor-standing units can easily be installed along a perimeter wall. The air distribution from these models will allow you to find the right balance for classrooms, churches, office hallways or similar spaces.

### Features and Benefits

- » Ideal for installation beneath a window
- » Unit requires minimal installation space
- » Fitted with a washable long-life filter
- » Remote-control options available
- » Space-saving unit can be freestanding or wall-mounted
- » Models range from 7.5 MBH to 24 MBH



BRC1NRV71/72  
(option)



AZAI6WSPDKA  
(option)



BRC4C82  
(option)



BRC1H71W  
(option)



AZAI6WSPDKC  
(option)

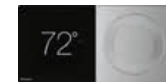

DTST-CWBSA-NI-B  
(option)



DTST-TOU-A  
(option)

### Applications

- » Multi-family residences
- » Single-family residences
- » Churches
- » Historic buildings
- » Schools
- » Offices



FXLQ_MVJU9 SPECIFICATIONS		0.6 TON	0.75 TON	1 TON	1.5 TON	2 TON
Model Name		FXLQ07MVJU9	FXLQ09MVJU9	FXLQ12MVJU9	FXLQ18MVJU9	FXLQ24MVJU9
Power Supply	V/ph/Hz	208-230/1/60				
Rated Cooling Capacity	BTU/h	7,500	9,500	12,000	18,000	24,000
Rated Heating Capacity	BTU/h	8,500	10,500	13,500	20,000	27,000
Airflow Rate (H/L)	CFM	245/210		280/210	490/380	560/420
Weight	lbs.	58		66	80	
Height	in.	23-5/8				
Width	in.	39-3/8		44-7/8	55-7/8	
Depth	in.	8-3/4				
Sound Pressure (H/L)	dB(A)	35/32		36/33	40/35	41/36
Condensate Pipe Connection	in. O.D.	27/32				
Pipe Connections	Gas	1/2 (Flare)				5/8 (Flare)
	Liquid	1/4 (Flare)				3/8 (Flare)
Refrigerant		R-410A				
Refrigerant Control		Electronic Expansion Valve				
Maximum Overcurrent Protective Device	A	15				
Minimum Circuit Amps	A	0.3		0.5	0.6	
Protection Devices		Fuse and Fan Motor Thermal Protector				
External Finish		Ivory White Casing				
Standard Filter Type		Resin Net (with Mold Resistant)				

**Nominal Conditions:**

**Cooling Mode**

Indoor: 80°F DB / 67°F WB  
 Outdoor: 95°F DB  
 Pipe Length: 25 ft.  
 Level Difference: 0 ft.

**Heating Mode**

Indoor: 70°F DB  
 Outdoor: 47°F DB / 43°F WB  
 Pipe Length: 25 ft.  
 Level Difference: 0 ft.

**Note:** Specifications are subject to change without notice.

FXLQ_MVJU9 ACCESSORIES	FXLQ12MVJU9	FXLQ18MVJU9	FXLQ24MVJU9	FXNQ12MVJU9	FXNQ18MVJU9	FXNQ24MVJU9
Model Name						
Navigation Remote Controller*				BRC1NRFV71/72		
DKN Cloud Wi-Fi Adaptor				AZA16WSCDKA		
Madoka Remote Controller				BRC1H71W		
Button Sensor Kit				KRCSH2018-02		
Daikin ONE+ Smart Thermostat				DTST-CWBSA-NI-B		
DKN Plus Interface				AZA16WSPDKC		
Daikin ONE Touch				DTST-TOU-A		
Wireless Remote Controller				BRC4C82		
Remote Sensor Kit				KRCS01-1B		
Wiring Adaptor PCB (interface with aux/primary heater, humidifier, OA damper/fan)				KRP1C74		
Group Control Adaptor PCB (connects to external BMS)				KRP4A71		

\* Optional face plates available to provide a more intuitive user interface and disable specific functions

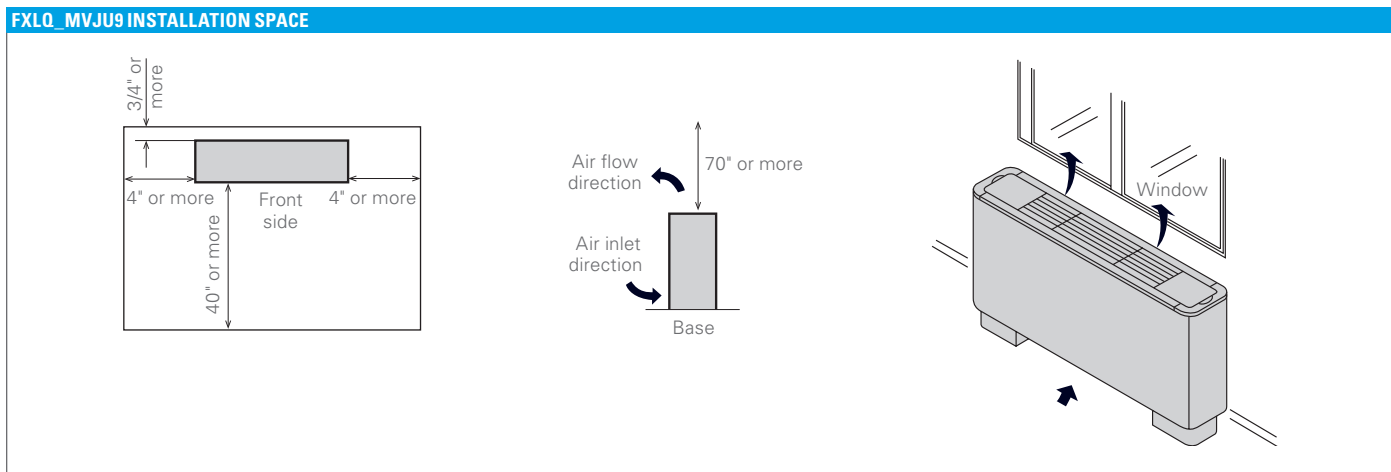

# FXFA\_AAVJU (R-32)

## Round Flow Sensing Cassette



Condensate Pump as Standard



Outside Air Integration Possible



Filter Included



Optional Auto Cleaning Filter



Surface & Occupancy Sensor Kit as Standard

### R32

#### Adaptive Comfort Control

The *Round Flow Sensing Cassette* is ideal for open-plan applications such as classrooms and offices where adaptive comfort control is preferred. The unit provides excellent comfort, energy efficiency, and flexibility due to innovative control functions based on input from three room sensors (occupancy, air temperature, and surface temperature). With 18 configurable airflow distribution patterns, it can be efficient and provide a comfortable environment in smaller, more intricate spaces as well.

#### Low GWP R-32 Refrigerant

Aligning with Daikin's goals of decarbonization, sustainability, and advancement towards clean energy, FXFA models feature Low GWP R-32 refrigerant. Widely used and proven globally, readily available, efficient, and affordable, R-32 is an ideal choice to replace R-410A. R-32 is a single component refrigerant offering simplicity and flexibility in charging, and reclaiming.

#### All R-32 VRV indoor units feature:

- » Factory-installed integrated refrigerant leak sensor
- » Dispersion Mode: Higher airflow rate for leak mitigation through circulation
- » On-board terminal for connection to external alarms and monitoring systems



BRC1NRV71/72



AZAI6WSPDKC (option)

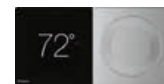

DTST-CWBSA-NI-B (option)



DTST-TOU-A (option)

#### Features and Benefits:

Capacity range from 0.6 to 4.5 Tons

- » True 360° Airflow with three room sensors enabling optimal occupant comfort and efficiency.
- » Application flexibility with 18 different airflow patterns ensures ideal air distribution to maximize comfort and efficiency.
- » Ease of outside air integration with optional fresh air intake kit
- » Energy efficient with DC fan motor and auto-logic that adjusts fan speed based on space load

#### 4-way flow vs. Round Flow

*Round Flow* Ceiling Mounted Cassette type offers 360° airflow with improved temperature distribution.

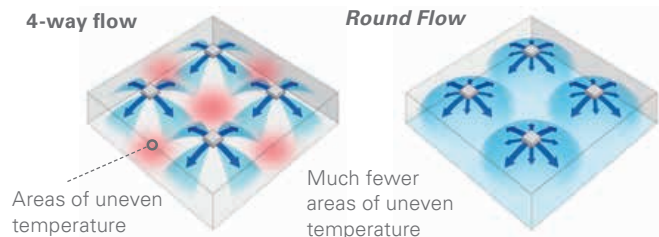

#### Applications

- » Retail
- » Schools
- » Offices
- » Restaurants

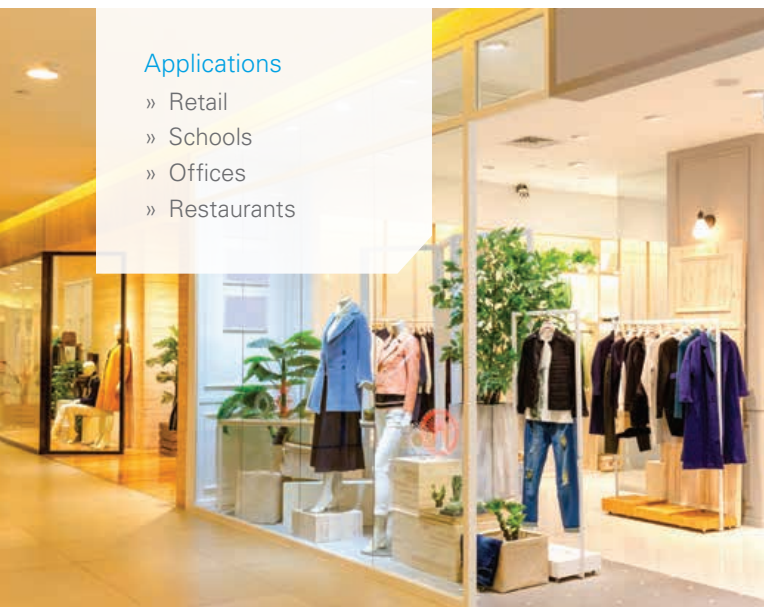



Advanced design for comfort and efficiency

**Heat Exchanger Design**

Optimized for part load operation — great enhancement to seasonal energy efficiency

**Occupancy and Surface Temperature Sensors**

Enables additional energy savings and increased comfort

**Optional Self-Cleaning Filter Panel**

Provides optimum efficiency, airflow and reduced maintenance

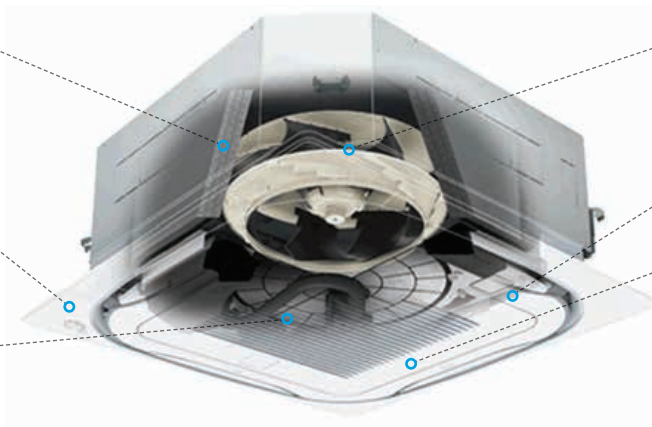

**DC Fan Motor**

Very efficient — enables fan auto logic based on  $\Delta T$  set point

**DC Drain Pump**

Low power consumption

**Decoration Panel**

- » Efficient due to large air discharge outlets
- » Unique 360° airflow distribution
- » 4 individually controlled louvers enables optimized comfort in the space
- » Possibility to close 1, 2 or 3 louvers adds flexibility

Automatic air-direction control

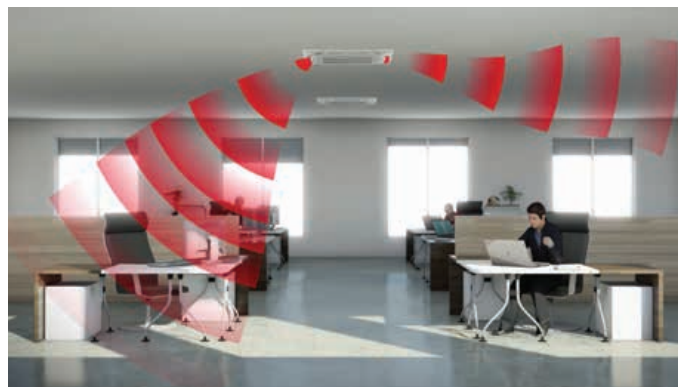

Air flow from the indoor unit is automatically adjusted to always maintain a comfortable environment — even when occupancy changes.

Dual infrared sensors

Sensors detect the presence of people and surface temperature to provide comfortable air-conditioning and energy savings.

**Infrared presence sensor**

The sensor detects human presence, and energy saving control can be performed when no people are detected.

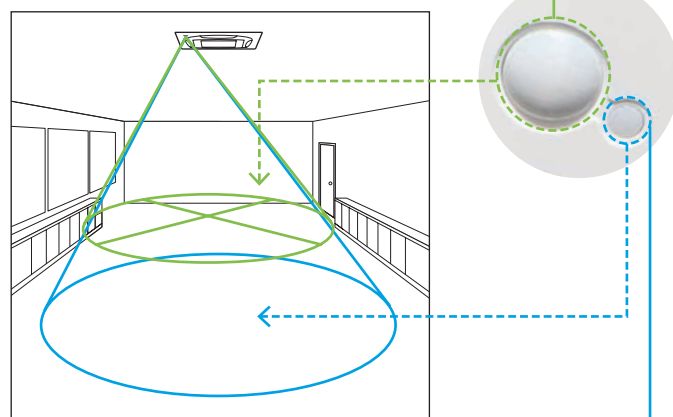

**Infrared surface sensor**

The sensor detects the surface temperature and automatically adjusts operation of the indoor unit to reduce the temperature difference between the ceiling and the floor.

# FXFA\_AAVJU (R-32) (cont.)

## Round Flow Sensing Cassette



Condensate Pump as Standard



Outside Air Integration Possible



Filter Included



Optional Auto Cleaning Filter



Surface & Occupancy Sensor Kit as Standard

Automatic air filter cleaning (optional)

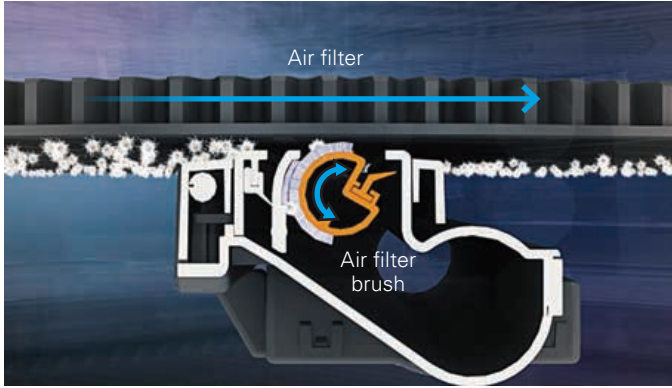

At the programmed time, the air filter rotates while the air filter brush turns back and forth to brush the filter.

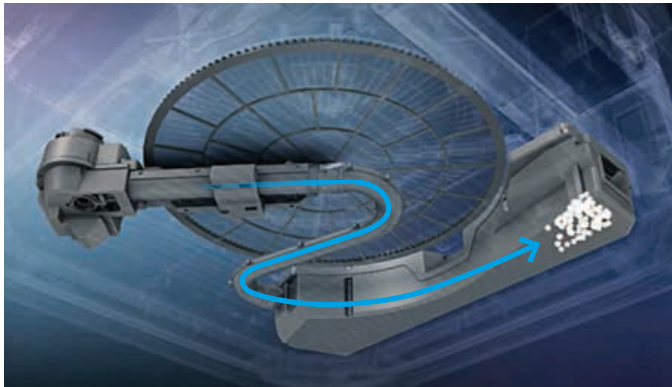

Dust from the air filter brush is deposited into the dust collection container during the fully automatic self-cleaning process.

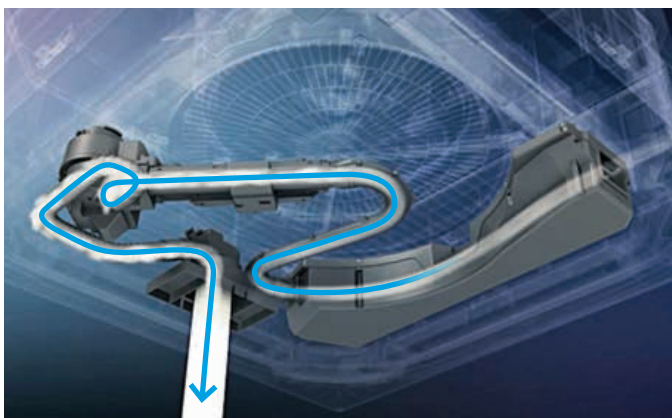

When indicated, the dust container in the unit is easily emptied with a standard vacuum cleaner.



FXFA_AAVJU SPECIFICATIONS		0.60 TON	0.75 TON	1 TON	1.25 TON	1.5 TON	2 TON	2.5 TON	3 TON	4 TON	4.5 TON	
Model Name		FXFA07AAVJU	FXFA09AAVJU	FXFA12AAVJU	FXFA15AAVJU	FXFA18AAVJU	FXFA24AAVJU	FXFA30AAVJU	FXFA36AAVJU	FXFA48AAVJU	FXFA54AAVJU	
Power Supply	(V/ph/Hz)	208-230/1/60										
Rated Cooling Capacity	BTU/h	7,200	9,500	12,000	14,400	18,000	23,000	30,000	36,000	48,000	54,000	
Rated Heating Capacity	BTU/h	8,500	10,500	13,500	17,000	20,000	27,000	34,000	40,000	48,000	60,000	
Refrigerant		R-32										
Refrigerant Control		Electronic Expansion Valve										
Airflow Rate H/M/L	CFM	441/406/353			512/459/388	547/477/388	777/618/477	1059/882/671	1253/918/671	1253/971/741	1253/1006/741	
Unit Weight	lbs	42					51	58				
Unit Height	in.	9-11/16					11-5/16					
Unit Width	in.	33-1/16					33-1/16					
Unit Depth	in.	33-1/16										
Sound Pressure H/M/L	dB(A)	30/28.5/27			31/29/27	35.5/32/28	36/32/28	43.5/38/32	44/38/32	45/40/35	47/41/36	
Unit Condensate Connection	in. O.D.	1-1/4										
Condensate Pump Lift	in.	33-1/2										
Pipe Connections	Gas	in. 1/2 (Flare)					in. 5/8 (Flare)					
	Liquid	in. 1/4 (Flare)					in. 3/8 (Flare)					
External Finish		Galvanized Steel Plate										
Protection Devices		Fuse/Breaker										
		Fan Motor Thermal Protector										
Recommended Fuse/Breaker	A	15										
Standard Filter Type		Mold-Resistant Resin Net										

**Nominal Conditions:**

**Cooling Mode**

Indoor: 80°F DB / 67°F WB  
 Outdoor: 95°F DB  
 Pipe Length: 25 ft.  
 Level Difference: 0 ft.

**Heating Mode**

Indoor: 70°F DB  
 Outdoor: 47°F DB / 43°F WB  
 Pipe Length: 25 ft.  
 Level Difference: 0 ft.

**Note:** Specifications are subject to change without notice.

**FXFA\_AAVJU ACCESSORIES WITH:**

Accessory	Item #	Self-Cleaning Filter Panel (BYCQ54EEGFU)	Standard Sensing Decoration Panel (BYCQ54EEFU)
Navigation Remote Controller	BBRC1NRV71	Yes <sup>1</sup>	Yes <sup>1</sup>
Remote Sensor Kit	KRCS01-6B	Yes	Yes
Outside Air Intake Kit	KAF555D160	-	Yes
Long-Life Replacement Air Filter	KAF5511D160	-	Yes
Panel Spacer	KDBP55H160FA	Yes	Yes

<sup>1</sup> No sensing functions available

<sup>2</sup> Optional face plates available to provide a more intuitive user interface and disable specific functions

**Features and Benefits (cont.)**

- » Optional self-cleaning filter panel to further increase efficiency and reduce maintenance costs, when used in VRF systems
- » Increased indoor air quality with high efficiency filter options and ventilation connection kit
- » Compact design to allow for installation in small ceiling voids Sound pressure levels as low as 27 db(A)

**FXFA INSTALLATION SPACE**

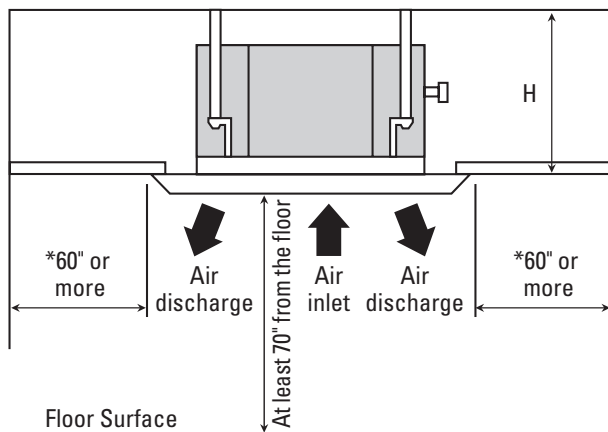

MODEL	HEIGHT
FXFA07-24AAVJU	11"
FXFA30-54AAVJU	12" or more

\* Leave 7 7/8" or more space on sides where the air outlet is closed.

# FXMA\_AAVJU (R-32) Ducted Concealed Unit



Condensate Pump  
as Standard



Outside Air  
Integration Possible



Drain Pan  
Inspection Port



Auto Fan Speed  
Control

## R32

### Powerful. Concealed. Flexible

Daikin's FXMA HSP Concealed Ducted unit offers design flexibility for many applications. Its compact design with a short chassis height of only 9-11/16" (245 mm) allows for installation in confined spaces. The high-efficiency DC fan motor delivers nominal CFM at up to 0.8" external static pressure. A selectable Auto fan\*\* speed control automatically adjusts the fan speed in response to the room temperature to deliver ideal comfort and help reduce fan energy use.

### Low GWP R-32 Refrigerant

Aligning with Daikin's goals of decarbonization, sustainability, and advancement towards clean energy, FXMA models feature Low GWP R-32 refrigerant. Widely used and proven globally, readily available, efficient, and affordable, R-32 is an ideal choice to replace R-410A. R-32 is a single component refrigerant offering simplicity and flexibility in charging and reclaiming.

### All R-32 VRV indoor units feature:

- » Factory-installed integrated refrigerant leak sensor
- » Dispersion Mode: Higher airflow rate for leak mitigation through circulation
- » On-board terminal for connection to external alarms and monitoring systems

\*\* Auto fan speed requires the use of the BRC1NRV72 controller



BRC1NRV71/72



AZAI6WSPDKC  
(option)

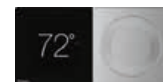

DTST-CWBSA-NI-B  
(option)



DTST-TOU-A  
(option)

### Features and Benefits:

- » DC fan motor efficiently provides nominal CFM at up to 0.8" W.G.
- » Installation flexibility with a low profile, compact design at less than 12" in height.
- » Reduced risk of condensation on air vents with minimal discharge air temperature setting.
- » Efficient operation using Variable Refrigerant Temperature (VRT).
- » Innovative economizer control logic.
- » Enhance indoor air quality (and LEED® ready) with MERV 13 filter options.
- » Ease of installation with auto-adjusting airflow at commissioning based on external static pressure.
- » Provides a high degree of control for auxiliary heating devices, with independently configurable on/off temperature values.
- » Easy maintenance with complete service access from below. Alternatively the installer can manually select a fan curve with the wired remote control.

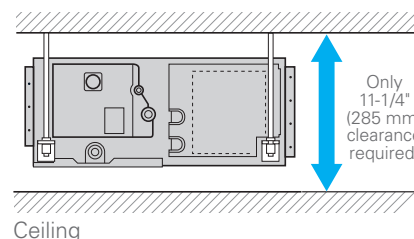

Dust from the air filter brush is deposited into the dust collection container during the fully automatic self-cleaning process.

When indicated, the dust container in the unit is easily emptied with a standard vacuum cleaner.

### Applications

- » Offices
- » Hotels
- » Schools
- » Retail

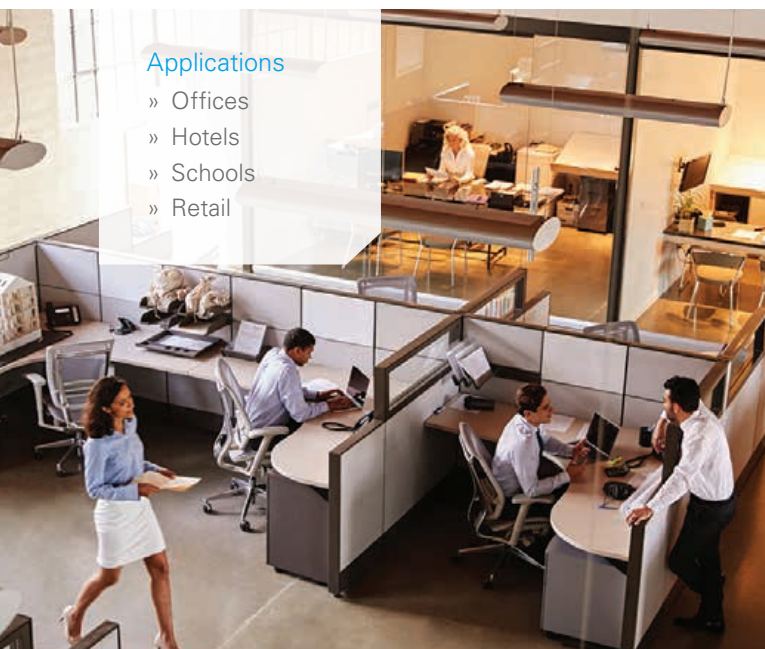

FXMA_AAVJU SPECIFICATIONS		1.25 TON	1.5 TON	2.0 TON	2.5 TON	3.0 TON	4.0 TON	4.5 TON
Model Name		FXMA15AAVJU	FXMA18AAVJU	FXMA24AAVJU	FXMA30AAVJU	FXMA36AAVJU	FXMA48AAVJU	FXMA54AAVJU
Power Supply	V/ph/Hz	Single-phase 208/230V 60Hz						
Rated Cooling Capacity	BTU/h	14,200 (4.2)	18,000 (5.3)	24,000 (7.0)	30,000 (8.8)	36,000 (10.6)	48,000 (14.1)	57,000 (16.7)
Rated Heating Capacity	BTU/h	17,000 (5.0)	20,000 (5.9)	27,000 (7.9)	34,000 (10.0)	40,000 (11.7)	54,000 (15.8)	63,000 (18.5)
Airflow Rate (H/M/L)	SCFM (M3/MIN)	560/447/406	635/565/512	742/635/565	1094/847/795	1130/953/795	1377/1130/918	1518/1235/989
	(m3/min)	(15.8/12.7/11.5)	(18.0/16.0/14.5)	(21.0/18.0/16.0)	(31.0/24/22.5)	(32.0/27.0/22.5)	(39.0/32.0/26.0)	(43.0/35.0/28.0)
Height	in.	9-11/16						
Width	in.	39-3/8			55-1/8			61
Depth	in.	31-1/2						
Condensate Pump Lift	in.	25-5/16						
Sound Level (Reference) *	Power dB(A)	65	64	67	71	72	76	80
	Pressure dB(A)	37/34/31	36/34/32	39/35/33	43/38/36	44/40/36	48/44/39	52/47/42
Weight	lbs (kg)	77 (35)		82 (37)	101 (46)		104 (47)	115 (52)
Condensate Pipe Connection	in. O.D.	VP25						
Pipe Connections	Gas	in. (mm) $\varnothing$ 1/4 ( $\varnothing$ 6.4) (Flare)			in. (mm) $\varnothing$ 3/8 ( $\varnothing$ 9.5) (Flare)			
	Liquid	in. (mm) $\varnothing$ 1/2 ( $\varnothing$ 12.7) (Flare)			in. (mm) $\varnothing$ 5/8 ( $\varnothing$ 15.9) Flare			
Refrigerant		R-32						
Refrigerant Control		Electronic Expansion Valve						
Maximum Overcurrent Protective Device	A	15						
Minimum Circuit Amps	A	1.8	1.9	3	3.1	3.6		
Protection Devices		Fuse and Fan Driver Overload Protector						
External Finish		Galvanized Steel Plate						
External Static Pressure (H/L)	in. W.G.	0.80/0.20						0.56/0.20

\* The sound power levels are based on ISO9614 and the sound pressure levels are based on JIS B 8616.

FXMA_AAVJU ACCESSORIES							
Model Name	FXMA15AAVJU	FXMA18AAVJU	FXMA24AAVJU	FXMA30AAVJU	FXMA36AAVJU	FXMA48AAVJU	FXMA54AAVJU
Navigation Remote Controller*				BRC1NRV71			
Remote Sensor Kit				KRCS01-6B			
Group Control Adapter PCB (connects to external BMS)				KRP4A71			

\* Optional face plates available to provide a more intuitive user interface and disable specific functions

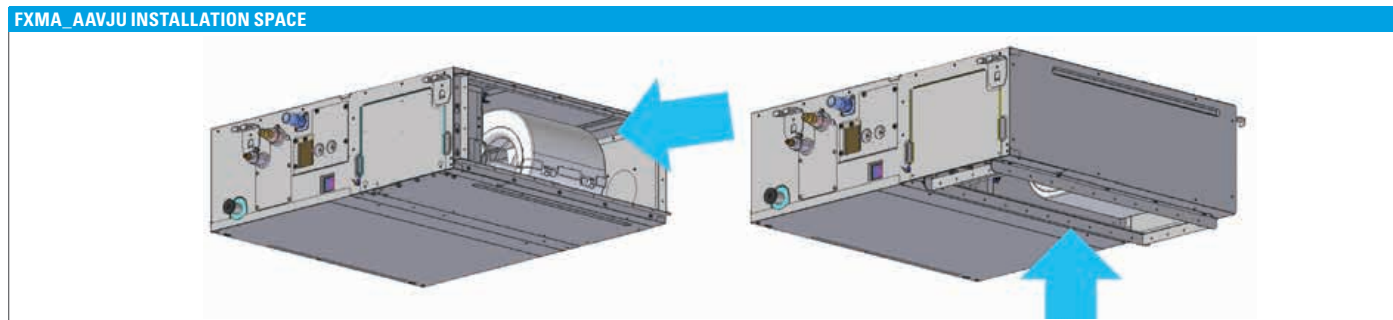

### Applications:



OFFICE



HOTELS



RETAIL



SCHOOLS

# FXSA\_AAVJU (R-32) MSP Concealed Ducted Unit



Condensate Pump  
as Standard



Outside Air  
Integration Possible



Drain Pan  
Inspection Port



Auto Fan Speed  
Control

## R32

Compact. Powerful. Comfortable.

Daikin's FXSA MSP Concealed Ducted unit offers designers a solution for navigating restrictive application setups. It features a high-efficiency DC fan motor that delivers nominal CFM up to a 0.6" external static pressure from within a compact body that requires only 11-1/4" of clearance space. Additionally, it includes a selectable Auto fan\* speed control feature that intelligently modifies the fan speed based on room temperature, enhancing comfort while minimizing fan energy consumption.

### Low GWP R-32 Refrigerant

Aligning with Daikin's goals of decarbonization, sustainability, and advancement towards clean energy, FXSA models feature Low GWP R-32 refrigerant. Widely used and proven globally, readily available, efficient, and affordable, R-32 is an ideal choice to replace R-410A. R-32 is a single component refrigerant offering simplicity and flexibility in charging, and reclaiming.

### All R-32 VRV indoor units feature:

- » Factory-installed integrated refrigerant leak sensor
- » Dispersion Mode: Higher airflow rate for leak mitigation through circulation
- » On-board terminal for connection to external alarms and monitoring systems

\* Refer to the installation manual for all installation clearance requirements.



BRC1NRV71/72



AZAI6WSPDKC  
(option)

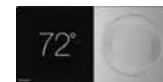

DTST-CWBSA-NI-B  
(option)



DTST-TOU-A  
(option)

### Features and Benefits:

- » Design for installation flexibility, with a factory rear-return configuration and field convertible to bottom return configuration.
- » Slender design requires only 11-1/4" clearance in ceiling space, allowing for installation in cramped applications.
- » Ease of installation with auto-adjusting airflow at commissioning based on external static pressure.
- » Powerful static pressure capability, with up to 0.6 in.w.g. (150Pa) external static pressure.
- » Enhanced comfort and humidity control with dehumidification cooling operation.
- » Minimal discharge air temperature settings help lower the risk of condensation on air vents.
- » Efficient operation using Variable Refrigerant Temperature (VRT).
- » Sound levels as low as 28 dB(A) for quiet operation.
- » Includes a high degree of control for auxiliary heating devices, with independently configurable on/off temperature values.
- » Integral condensate pump with up to 25-5/16" (643mm) of lift from the drain outlet.
- » A maintenance-friendly inspection port lets contractors quickly check the drain pan's conditions.
- » Provides a high degree of control for auxiliary heating devices, with independently configurable on/off temperature values.
- » Integral condensate pump with up to 25-5/16" (643mm) of lift from the drain outlet

### Applications

- » Offices
- » Hotel Rooms
- » Multi-family residences
- » Single-family residences
- » Schools

SPECIFICATIONS		0.5 TON	0.6 TON	0.75 TON	1.0 TON	1.25 TON	1.5 TON	
Model Name		FXSA05AAVJU	FXSA07AAVJU	FXSA09AAVJU	FXSA12AAVJU	FXSA15AAVJU	FXSA18AAVJU	
Capacity Index		5.8	7.5	9.5	12	15	18	
Power Supply	V/ph/Hz	208/230VAC, 60Hz, 1 phase						
Nominal Cooling Capacity*1	Btu/h (kW)	5,800 (1.7)	7,200 (2.1)	9,500 (2.8)	12,000 (3.5)	15,000 (4.4)	18,000 (5.3)	
Nominal Heating Capacity*2	Btu/h (kW)	6,500 (1.9)	8,500 (2.5)	10,500 (3.1)	13,500 (4.0)	17,000 (5.0)	20,000 (5.9)	
Fan	Type	Sirocco fan						
	Motor Output	W	78			130	230	
	Air Flow Rate (H/M/L)	CFM	281 / 265 / 230		318 / 265 / 230	335 / 283 / 247	530 / 441 / 371	
	Drive Type	DC Direct Drive						
	External Static Pressure (Std./Max)		0.2 / 0.6			0.4 / 0.6		
Height	in. (mm)	9-11/16						
Width	in. (mm)	21-11/16			27-9/16	39-3/8		
Depth	in. (mm)	31-1/2						
Weight (net)	lb. (kg)	55 (25)			60 (27)	77 (35)		
Condensate Pump Lift	in. (mm)	25-5/16 (643)						
Sound Pressure Level (H/M/L speed)	dB(A)	33 / 30 / 28			34 / 32 / 30	36 / 33 / 30	34 / 32 / 29	
Pipe Connections	Liquid	in. 1/4 (Flare)						
	Gas	in. 1/2 (Flare)						
	Condensate Drain	in. VP25						
Refrigerant		R32						
Refrigerant Control		Electronic Expansion Valve						
Maximum Overcurrent Protection Device	A	15						
Minimum Circuit Ampacity	A	0.8			1.4	1.6		
SPECIFICATIONS		2.0 TON	2.5 TON	3.0 TON	4.0 TON	4.5 TON		
Model Name		FXSA24AAVJU	FXSA30AAVJU	FXSA36AAVJU	FXSA48AAVJU	FXSA54AAVJU		
Capacity Index		24	30	36	48	54		
Power Supply	V/ph/Hz	208/230VAC, 60Hz, 1 phase						
Nominal Cooling Capacity*1	Btu/h (kW)	24,000 (7.0)	30,000 (8.8)	36,000 (10.6)	48,000 (14.1)	54,000 (15.8)		
Nominal Heating Capacity*2	Btu/h (kW)	27,000 (7.9)	34,000 (10.0)	40,000 (11.7)	54,000 (15.8)	60,000 (17.6)		
Fan	Type	Sirocco fan						
	Motor Output	W	230		300	350		
	Air Flow Rate (H/M/L)	CFM	742 / 618 / 512	812 / 689 / 565	1130 / 953 / 795	1307 / 1112 / 918	1377 / 1183 / 989	
	Drive Type	DC Direct Drive						
	External Static Pressure (Std./Max)		0.2 / 0.6				0.2 / 0.56	
Height	in. (mm)	9-11/16						
Width	in. (mm)	39-3/8			55-1/8	61		
Depth	in. (mm)	31-1/2						
Weight (net)	lb. (kg)	77 (35)	82 (37)	101 (46)	104 (47)	115 (52)		
Condensate Pump Lift	in. (mm)	25-5/16 (643 mm)						
Sound Pressure Level (H/M/L speed)	dB(A)	36 / 32 / 29	37.5 / 34 / 30	39 / 35 / 32	42 / 38.5 / 35	43 / 40 / 36		
Pipe Connections	Liquid	in. 3/8 (Flare)						
	Gas	in. 5/8 (Flare)						
	Condensate Drain	in. VP25						
Refrigerant		R32						
Refrigerant Control		Electronic Expansion Valve						
Maximum Overcurrent Protection Device	A	15						
Minimum Circuit Ampacity	A	1.8	2.5		2.8	3.3		

**Notes:** \*1 Nominal cooling capacities are based on the following conditions: 80°F DB / 67°F WB (26.7°C DB / 19.4°C WB) return air temperature; 95°F DB (35°C DB) outdoor temperature; 25 ft. (7.6 m) equivalent refrigerant piping.

\*2 Nominal heating capacities are based on the following conditions: 70°F DB (21.1°C DB) return air temperature; 47°F DB / 43°F WB (8.3°C DB / 6.1°C WB) outdoor temperature; 25 ft. (7.6 m) equivalent refrigerant piping.

## Capacity Range: 0.5 to 4.5 tons Applications:



OFFICE



HOTELS



RESIDENTIAL



SCHOOLS

## Flexible Installation.

The FXSA can easily be converted to a bottom-return configuration to optimize the use of space above the ceiling or bulkhead space.

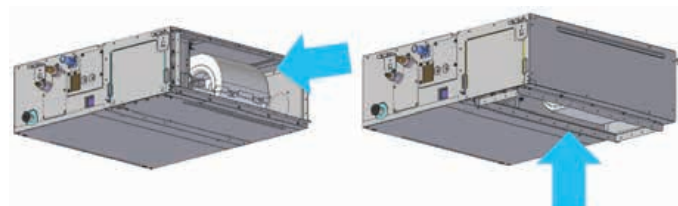

# FXTA\_AAVJU (R-32)

## Multi-Position Air Handling Unit



Outside Air  
Integration  
Possible



All  
Aluminum  
Coil



Variable  
Speed  
ECM Motor



### R32

#### Outstanding flexibility and performance

The FXTA air handler features full multi-position\* flexibility to meet the most demanding installation conditions. With its compact and space-saving design at under 46" tall and only 17-1/2" wide up to 3 tons, the FXTA is an ideal choice for tight closet spaces. The FXTA is also designed for zero clearance on three sides and only 24" clearance on the front side for service facilitating installation in restricted spaces.

#### Low GWP R-32 Refrigerant

Aligning with Daikin's goals of decarbonization, sustainability, and advancement towards clean energy, FXTA models feature Low GWP R-32 refrigerant. Widely used and proven globally, readily available, efficient, and affordable, R-32 is an ideal choice to replace R-410A. R-32 is a single component refrigerant offering simplicity and flexibility in charging, and reclaiming.

#### All R-32 VRV indoor units feature:

- » Factory-installed integrated refrigerant leak sensor
- » Dispersion Mode: Higher airflow rate for leak mitigation through circulation
- » On-board terminal for connection to external alarms and monitoring systems

#### Features and Benefits:

- » This full multi-position air handler can upflow, downflow\*, horizontal right, and horizontal left installation.
- » High efficiency, ECM motor powers the fan to deliver nominal CFM at up to 0.9" w.g. static.
- » The auto fan speed setting automatically adjusts the fan speed through 5 steps based on the load in the space.
- » Broad line up of electric heat (field installed) options from 3kW to 25kW.



BRC1NRV71/72



AZAI6WSPDKC  
(option)



DTST-TOU-A  
(option)



DTST-CWBSA-NI-B  
(option)

- » Auxiliary heat logic features a reduced heater operation deadband and the ability to run heat pump and auxiliary heat for maximum comfort and performance in colder climates. The auxiliary heat can be interlocked with the ambient temperature sensed by the outdoor unit.
- » Designed with less than 2% air leakage when tested in accordance with ASHRAE standard 193.
- » Easy integration with third-party accessories such as a humidifier or economizer with on-board contacts.
- » Sound levels as low as 36 dBA for operation in sound-sensitive environments
- » Optional factory-installed disconnect (Built-to-order — model FXTA\_AAVJUA(D)).

#### Applications

- » Multi-family
- » Single-family
- » Hotels
- » Offices





SPECIFICATIONS		0.75 TON	1 TON	1.5 TON	2 TON	2.5 TON	
Model Name		FXTA09AAVJUA	FXTA12AAVJUA	FXTA18AAVJUA	FXTA24AAVJUA	FXTA30AAVJUA	
Model Name (With factory disconnect)		FXTA09AAVJUD	FXTA12AAVJUD	FXTA18AAVJUD	FXTA24AAVJUD	FXTA30AAVJUD	
Power Supply	V/ph/Hz	208/230VAC, 60Hz, 1 phase					
Nominal Cooling Capacity*1	Btu/h	9,500	12,000	18,000	24,000	30,000	
Nominal Heating Capacity*2	Btu/h	10,500	13,500	20,000	27,000	34,000	
Fan	Type	Sirocco FC Centrifugal					
	Air Flow Rate (H/M/L)	CFM	300 / 275 / 250	400 / 340 / 280	600 / 510 / 420	800 / 680 / 560	1000 / 850 / 700
	Static Pressure*3	in w.g.	0.18" / 0.9"			0.23" / 0.9"	
	Drive Type	Variable speed ECM					
Height	in.	45					
Width	in.	17.5					
Depth	in.	21					
Weight (net) (TAVJUA/TAVJUD)	lbs.	105/108	112/115	111/118	112/115	113/116	
Sound Pressure Level (H speed)	dB(A)	36		45		52	
Pipe Connections	Liquid	in.	1/4 (Braze)		3/8 (Braze)		
	Gas	in.	1/2 (Braze)		5/8 (Braze)		
	Condensate Drain	in.	3/4 (fpt)				
Refrigerant		R32					
Refrigerant Control		Electronic Expansion Valve					
Maximum Overcurrent Protective Device	A	15					
Minimum Circuit Amps	A	4.9					

SPECIFICATIONS		3 TON	3.5 TON	4 TON	4.5 TON	5 TON	
Model Name		FXTA36AAVJUD	FXTA42AAVJUA	FXTA48AAVJUA	FXTA54AAVJUA	FXTA60AAVJUA	
Model Name (With factory disconnect)		FXTA36AAVJUD	FXTA42AAVJUD	FXTA48AAVJUD	FXTA54AAVJUD	FXTA60AAVJUD	
Power Supply	V/ph/Hz	208/230VAC, 60Hz, 1 phase					
Nominal Cooling Capacity*1	Btu/h	36,000	42,000	48,000	54,000	60,000	
Nominal Heating Capacity*2	Btu/h	40,000	46,000	54,000	60,000	66,000	
Fan	Type	Sirocco FC Centrifugal					
	Air Flow Rate (H/M/L)	CFM	1050 / 900 / 750	1400 / 1190 / 980	1520 / 1290 / 1060	1800 / 1530 / 1260	1800 / 1530 / 120
	Static Pressure*3	in w.g.	0.23" / 0.9"			0.28" / 0.9"	
	Drive Type	Variable speed ECM					
Height	in.	45	53.43		58		
Width	in.	17.5	21		24.5		
Depth	in.	21					
Weight (net) (TAVJUA/TAVJUD)	lbs.	113/116	144/147		165/168		
Sound Pressure Level (H speed)	dB(A)	52	54		50		
Pipe Connections	Liquid	in.	3/8 (Braze)				
	Gas	in.	5/8 (Braze)				
	Condensate Drain	in.	3/4 (fpt)				
Refrigerant		R32					
Refrigerant Control		Electronic Expansion Valve					
Maximum Overcurrent Protective Device	A	15					
Minimum Circuit Amps	A	4.9	6.5		8.6		

**Notes:** \*1 Nominal cooling capacities are based on the following conditions: 80 °FDB / 67 °FWB (26.7 °CDB / 19.4 °CWB) return air temperature; 95 °FDB (35 °CDB) outdoor temperature; 25 ft. (7.6 m) equivalent refrigerant piping.

\*2 Nominal heating capacities are based on the following conditions: 70 °FDB (21.1 °CDB) return air temperature; 47 °FDB / 43 °FWB (8.3 °CDB / 6.1 °CWB) outdoor temperature; 25 ft. (7.6 m) equivalent refrigerant piping.

\*3 External static pressures are indicated as rated / maximum allowable range.

## Electric Heater Options

ELECTRICAL HEATER CAPACITY									
Model Name	3kW	5kW	6kW	8kW	10kW	15kW	19kW	20kW	25kW
FXTA09AAVJUA(D)	■	■							
FXTA12AAVJUA(D)	■	■	■						
FXTA18AAVJUA(D)	■	■	■	■	■				
FXTA24AAVJUA(D)	■	■	■	■	■				
FXTA30AAVJUA(D)	■	■	■	■	■				
FXTA36AAVJUA(D)	■	■	■	■	■				
FXTA42AAVJUA(D)		■	■	■	■	■	■		
FXTA48AAVJUA(D)		■	■	■	■	■	■		
FXTA54AAVJUA(D)		■	■	■	■	■		■	■
FXTA60AAVJUA(D)		■	■	■	■	■		■	■

## Applications:



# FXZA\_AAVJU (R-32)

## VISTA 2 x 2 Cassette Unit for VRV



Condensate Pump  
as Standard



Outside Air  
Integration Possible



Filter  
Included

### R32

#### Designer Comfort

VISTA is a remarkable blend of iconic design and engineering excellence with an elegant white or a silver and white finish. Fitting within the ceiling grid, VISTA is stylish, low profile, and compact. Energy efficiency and comfort can be enhanced through the combined use of optional floor and presence sensors. It is also possible to close individual louvers via the wired remote control for personalized comfort.

#### Features and Benefits

- » Six capacity options, from 5,800 Btu/h to 18,000 Btu/h
- » 4-way, 3-way, and 2-way blow configurability
- » Independently motorized louver outlets
- » High efficiency DC fan motor with Auto fan speed control
- » Low profile decoration panel design measures a mere 5/16" below the ceiling
- » Integral condensate pump with up to 24-13/16" (630mm) lift from the drain outlet
- » Independently configurable auxiliary heat on/off temperatures
- » Outside air integration possible
- » One decoration panel design color available

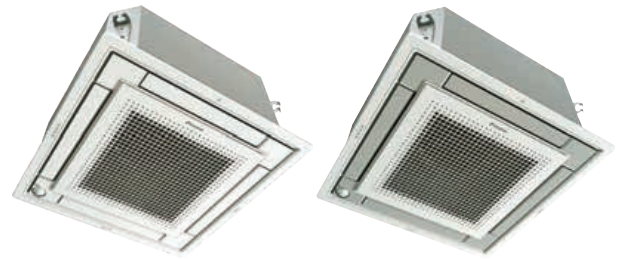

BRC1NRV71/72  
(option)



DTST-TOU-A  
(option)

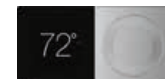

DTST-CWBSA-NI-B  
(option)



DKN Plus Interface  
(AZAI6WSPDKC)

#### R-32 Features

- » Factory-installed integrated refrigerant leak sensor
- » Dispersion Mode: Higher airflow rate for leak mitigation through circulation
- » Terminal for connection, via optional relay PCB, to external alarms and monitoring systems

#### Flexible Airflow Patterns

The four air louvers in the unit enables comfortable space environment in many different room layouts.

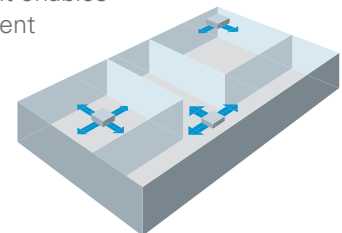

#### Applications

- » Retail
- » Schools
- » Offices

#### Airflow Angles

**Auto Swing:** Wide discharge angle: 0° to 60°

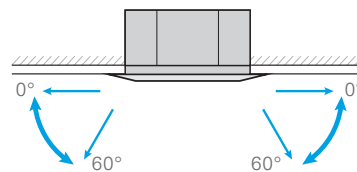

**Fixed Angles:** 5 Levels

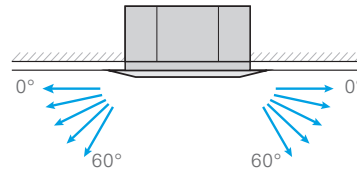

Angles can be also set on site to prevent drafts (0°-35°) or soiling of the ceiling (25°-60°), other than standard setting (0°-60°).

2X2 CASSETTE (FXZA)		0.50 Ton	0.6 Ton	0.75 Ton	1 Ton	1.25 Ton	1.5 Ton
Model Name		FXZA05AAVJU	FXZA07AAVJU	FXZA09AAVJU	FXZA12AAVJU	FXZA15AAVJU	FXZA18AAVJU
Model Name (Panel)		BYFQ18GU					
Power Supply		(V/ph/Hz) 208-230/1/60					
Nominal Cooling Capacity*1		BTU/h 5,800	7,500	9,500	12,000	15,000	18,000
Nominal Heating Capacity *2		BTU/h 6,500	8,500	10,500	13,500	17,000	20,000
Refrigerant		R-32					
Refrigerant Control		Electronic Expansion Valve					
Dimensions (Unit)		(HxWxD) 10-1/4 x 22-5/8 x 22-5/8					
Dimensions (Panel)		(HxWxD) [BYFQ18GU] 1-13/16 x 24-7/16 x 24-7/16					
Weight (Unit)		lbs. 35.3			36.4		41.9
Weight (Panel)		lbs. 6.2					
Airflow Rate H/M/L		CFM 300/247/229	307/264/229	317/282/229	353/300/247	405/335/282	511/441/353
Sound Power Level		dBA (H) 49		50	51	54	60
Sound Pressure Level H/M/L		dBA 32/29.5/25.5	32/29.5/25.5	33/30/25.5	33.5/30/26	37/32/28	43/40/33

**Notes:** \*1 Nominal cooling capacities are based on the following conditions: 80°F DB / 67°F WB (26.7°C DB / 19.4°C WB) return air temperature; 95°F DB (35°C DB) outdoor temperature; 25 ft. (7.6 m) equivalent refrigerant piping.  
 \*2 Nominal heating capacities are based on the following conditions: 70°F DB (21.1°C DB) return air temperature; 47°F DB / 43°F WB (8.3°C DB / 6.1°C WB) outdoor temperature; 25 ft. (7.6 m) equivalent refrigerant piping.

FXZA_AAVJU ACCESSORIES						
	0.50 Ton	0.6 Ton	0.75 Ton	1 Ton	1.25 Ton	1.5 Ton
Model Name	FXZA05AAVJU	FXZA07AAVJU	FXZA09AAVJU	FXZA12AAVJU	FXZA15AAVJU	FXZA18AAVJU
Decoration panel	BYFQ18GU					
Sensor kit	BRE44B1F					
Sealing Member of Air Discharge Kit	BDBHQ44C60					
Replacement long life filter	KAF441C60					
Fresh Air Intake Kit	KDDQ44XA60					
Remote Controller	BRC1NRV71					
Remote Sensor	KRCS01-6B					
Intelligent Touch Manager	DCM601B71 (requires "D3-D4 conversion adaptor")					
iTM plus adaptor	DGE601A72, DGE601A53					
D3-D4 conversion adaptor	BRD72A-L					
Wiring adaptor PCB	KRP1C77					
Group control adaptor PCB	KRP4A74*1					
Adaptor for multi tenant	TBD					
Installation box for Adaptor PCB	KRP1BD101					
Safety shut-off valve unit	SVA60/96AAVJ					
Relay PCB	BRP9A71					

\*1 A power supply harness is required for connection to the PCB of indoor unit

### FXZA\_AAVJU INSTALLATION SPACE

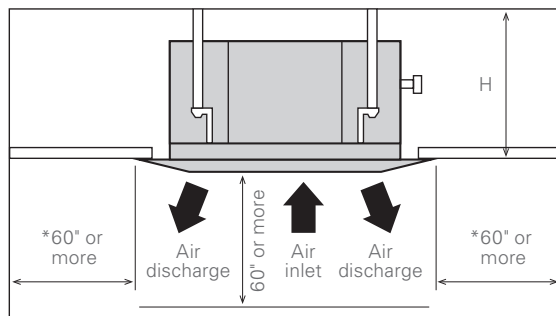

MODEL	HEIGHT
FXZA05-18TBVJU	11.75" or more

\*Leave 7-7/8" or more space on sides where the air outlet is closed.

## FXAA\_AAVJU (R-32) Wall-Mounted Unit



Optional  
Condensate Pump



Filter  
Included

### R32

#### Stylish, Compact, Convenient, Comfortable

Daikin's wall-mounted units are ideal for cooling or heating smaller zones such as stores, offices, and restaurants. The compact, stylish design lets the unit blend discreetly into any interior design, and airflow can be supplied in any of five different directions and easily programmed via remote control.



#### Features and Benefits

- » Expanded lineup includes a new 5,000 Btu/hr nominal capacity unit
- » Efficient operation year-round through Smart Variable Refrigerant Temperature (VRT) technology
- » Maintenance friendly design with new removable drain pan
- » Improved comfort cooling capability with individual evaporating temperature control
- » New automatic airflow flap control capable of both left/right and up/down direction control
- » New D4 communication protocol which allows for remote field settings for the system



BRC1NRV71/72  
(option)



DTST-TOU-A  
(option)

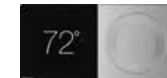

DTST-CWBSA-NI-B  
(option)



DKN Plus Interface  
(AZAI6WSPDKC)

#### R-32 Features

- » Factory installed integrated refrigerant leak sensor
- » Dispersion mode enables high airflow rates for leak mitigation
- » Output to external devices such as ventilation, dampers, alarms and monitoring systems

#### Applications

- » Retail
- » Restaurants
- » Offices
- » Hotels
- » Multi-family residences



WALL MOUNT (FXAA)		0.50 Ton	0.6 Ton	0.75 Ton	1 Ton	1.5 Ton	2 Ton
Model Name		FXAA05AAVJU	FXAA07AAVJU	FXAA09AAVJU	FXAA12AAVJU	FXAA18AAVJU	FXAA24AAVJU
Power Supply	(V/ph/Hz)	208-230/1/60					
Nominal Cooling Capacity*1	BTU/h	5,400	7,500	9,500	12,000	18,000	24,000
Nominal Heating Capacity *2	BTU/h	6,100	8,500	10,500	13,500	20,000	27,000
Refrigerant		R-32					
Refrigerant Control		Electronic Expansion Valve					
Dimensions (Unit)	(HxWxD) in.	11-5/8 x 33-13/16 x 9-3/4				11-5/8 x 44-1/8 x 9-3/4	
Weight (Unit)	lbs.	26.5				35.3	
Airflow Rate H/M/L		247/229/194	282/247/194	353/300/247	406/335/247	512/423/353	670/565/476
Sound Power Level		51	52	54	57	56	63
Sound Pressure Level H/M/L		33/30/28	34/32/28	36/32/29	39/34/29	38/34/31	45/40/35

**Notes:** \*1 Nominal cooling capacities are based on the following conditions: 80°F DB / 67°F WB (26.7°C DB / 19.4°C WB) return air temperature; 95°F DB (35°C DB) outdoor temperature; 25 ft. (7.6 m) equivalent refrigerant piping.  
 \*2 Nominal heating capacities are based on the following conditions: 70°F DB (21.1°C DB) return air temperature; 47°F DB / 43°F WB (8.3°C DB / 6.1°C WB) outdoor temperature; 25 ft. (7.6 m) equivalent refrigerant piping.

FXAA_AAVJU ACCESSORIES						
Model Name	0.50 Ton	0.6 Ton	0.75 Ton	1 Ton	1.5 Ton	2 Ton
Remote Controller	BRC1NRV71/72					
Intelligent Touch Manager	(requires D3/D4 Adaptor)					
D3-D4 conversion adaptor	BRD72A-L					
Wiring adaptor PCB	KRP1C77					
Group control adaptor PCB	KRP4A74					
Safety shut-off valve unit	SSOV Box					
Relay PCB	BRP9A72					

\*1 A power supply harness is required for connection to the PCB of indoor unit

**FXAA\_PVJU INSTALLATION SPACE**

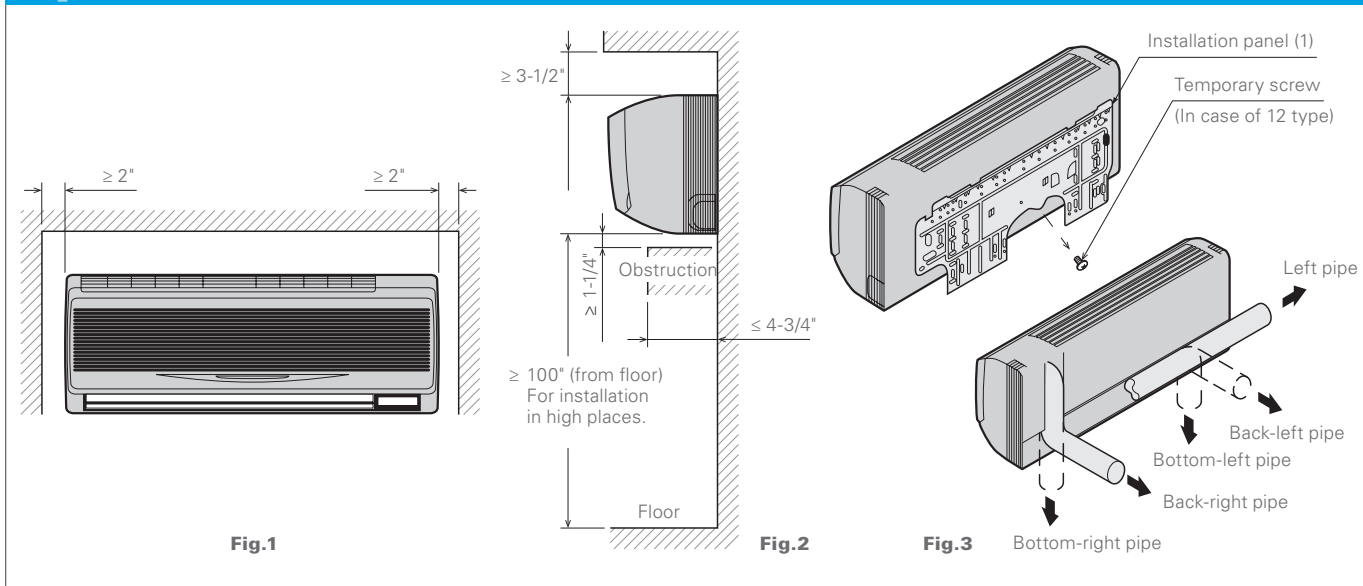

**Fig.1**

**Fig.2**

**Fig.3**

# DZK

## Daikin Zoning Kit

### Kits and Accessories



The optional Daikin Zoning Kit (DZK) increases the flexibility of the Daikin VRV systems by adding a Zoning Box to an indoor unit fan coil, allowing several separate ducts to supply air to different individually-controlled zones in the building. A zone can be a room, part of room, or several rooms. This flexible and scalable Zoning Kit integrates seamlessly with the indoor unit fan coil controls. The DZK system controls work to establish the required set-point, fan speed and mode of operation that is then requested to the VRV indoor unit via the Daikin zone controller. This allows the internal DZK control algorithms to look at the number of zone dampers in operation, and at what position the dampers need to be and adjust the VRV indoor unit operation accordingly. The DZK system is not directly compatible with the suite of Daikin centralized control options such as *iTM*.

A complete Daikin Zoning Kit consists of Zoning Box (with Control Board), Wired Thermostat, and Wireless Thermostats. The optional DZK BACnet Interface enables any BACnet/IP compatible Building Management System to be used for remote monitoring and control of the DZK.

#### Wired Thermostat

The 4th generation DZK introduces a software redesign for the Wired thermostat. The revised software offers a simplistic interface for commissioning DZK controls for an enhanced user experience.



The Wired thermostat in the DZK is a graphical colored, touch-screen interface with text menus, intuitive icons, and guided scheduling capability. It displays temperatures and operating values, and selects the operating mode for the system.

#### Wireless Thermostats

The optional Wireless thermostat offers a backlit, low energy E Ink display with capacitive touch buttons. The user can adjust the zone set point temperature, set user mode schedules, activate local ventilation, and more.



The optional Wireless Lite thermostat offers a sleek, simple user interface to adjust the local zone set point temperature using led-lit capacitive touch buttons.



#### Now with BACnet®/IP compatibility

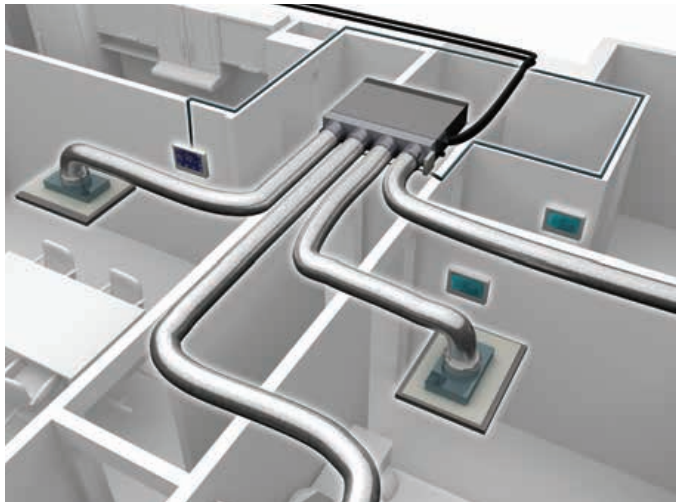

#### Zoning Box with Control Box (Model Depends on Indoor Unit)

The Zoning Box in the Daikin Zoning Kit mounts easily on Daikin's Indoor Unit FXMQ-P or FXSQ series fan coils. It consists of the enclosure, individually motorized dampers, and a control box. It is available in different sizes and damper configurations and by utilizing ducts for air supply it can be used to control the air temperature in up to 6 zones. The wired thermostat and the wireless thermostats provide temperature inputs and user interfaces for programming and adjustment of the control functions for each zone.



#### Daikin BACnet HUB4 Module

The DZK BACnet HUB module will work with any BACnet/IP & BACnet/MSTP compatible Building Management System. The DZK BACnet Hub is now Wi-Fi capable and provides remote access via the Airzone Cloud app or device web browser. (DZK-BACnet-HUB4)



BACnet® is a trademark of ASHRAE.

DAIKIN ZONING KIT (DZK) - GENERAL TECHNICAL DATA											
DZK Model		DZKS015E3-4	DZKS015E4-3	DZKS030E4-3	DZKS030E5-4	DZKS048E4-4	DZKS048E6-4	DZK030E4-4	DZK030E5-4	DZK048E4-4	DZK048E6-4
Height	in.	9-5/8	9-5/16	9-5/8	9-5/16	9-5/8	9-5/16	10-7/16	10-1/4	10-7/16	10-1/4
Width	in.	34-3/16		43-5/8		53-7/16		43-9/16		53-7/16	
Depth	in.	10-7/16									
Weight	lb.	16	18	18	20	18	23	18	20	20	23
No. of Zones		3	4	4	5	4	6	4	5	4	6
Ø of Outlets	in.	8	6	8	6	8	6	8	6	8	6
Power Supply	VAC	110/230 VAC									
	ph	1									
	Hz	60									

DAIKIN ZONING KIT (DZK) - COMPATIBILITY						
VRV Indoor Unit	DZKS015E4-4	DZKS015E4-4	DZKS030E4-4	DZKS030E5-4	DZKS048E4-4	DZKS048E6-4
FXSQ15TAVJU	■	■				
FXMQ15/18/24TBVJU			■	■		
FXMQ30/36/48TBVJU					■	■
DZK-MTS-4-W*	■	■	■	■	■	■
DZK-ZTS-4-W	■	■	■	■	■	■
DZK-LTS-4-W	■	■	■	■	■	■
DZK-BACNET-HUB4	■	■	■	■	■	■

\*Minimum (1) required per DZK Zoning Kit

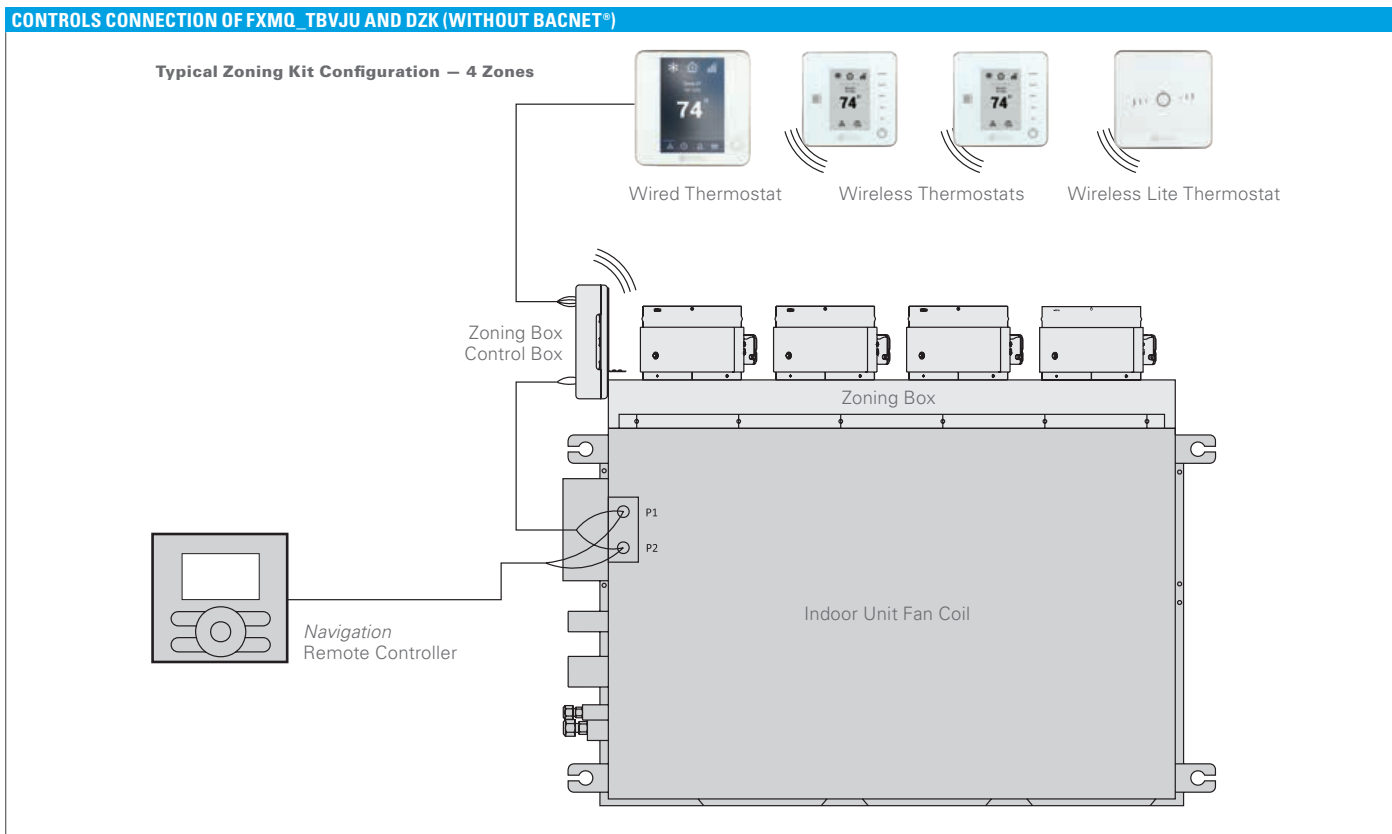

BACnet® is a trademark of ASHRAE.





# Outdoor Units



## VRV EMERION

### Air-Cooled Heat Recovery



Daikin *VRV EMERION* is available in single and dual-module lineups. The introduction of new 16-20 T single modules allows a system capacity of up to 40 Tons with just two modules. This helps reduce the overall space required for mechanical equipment and optimizes total project costs.

#### Features and Benefits

- » New Simple and Stylish design with expanded line up with single module units from 6-20T and dual-modules up to 40T
- » Space-saving 16 - 20 T single module units provide up to 34% footprint and up to 500 lbs./unit weight reduction compared to previous series<sup>2</sup>
- » High energy efficiency with IEERs up to 28.5 delivers up to 30% efficiency increase
- » Year-round comfort and energy saving with Daikin's Variable Refrigerant Temperature Technology (VRT)
- » Heating down to -13°F as standard and high heating capacities at 17°F make it an ideal choice for all-electric heat pump solutions
- » Hot gas defrost circuit allows for installation without base pan heater
- » High dust moisture protection with an IP55 rated sealed E-box
- » Dual-Fuel ready with connectivity to Daikin communicating gas furnace or all-electric heat pump heating for optimized operational cost based on utility rates
- » Increased piping lengths of up to 361 ft. vertical separation between ODU and IDU provide additional application flexibility compared to previous *VRV* systems<sup>1</sup>
- » Design flexibility to enlarge system from single to a dual-module without changes to installed main pipe sizes for phased installation or tenant fit-out buildings
- » Local code compliance-ready from factory via alignment with compliance needs, such as OSHPD Seismic, Miami Dade Wind, and Chicago Pressure relief code
- » Reduced wiring costs with up to 27.4% reduction in MCA values compared to previous series
- » Engineered for ease of installation and service with three-segment panel design
- » Factory ships with increase space for easy field piping connection to service valves



- » Built-in data recorder to store up to 40 minutes of operational data
- » Integrates with new Daikin *HERO* ecosystem, an IoT-based remote monitoring and diagnostics platform
- » Connect non standard *VRV* terminal units and AHUs with Daikin *VRV EMERION* leveraging Daikin Air Handling Unit Integration Kit to extend benefits of inverter technology to custom terminal units and AHUs. A kit consists of One Control Box and One EEV box. Offered via EKEQMCBAV3-US and EKEQFCBAV3-US.

<sup>1</sup> Refer to engineering and installation manuals for application rules.

<sup>2</sup> Model specific; check product specification for details.



\* Complete commercial warranty details available from your local distributor or manufacturer's representative or at [www.daikincomfort.com](http://www.daikincomfort.com).



**VRV EMERION CERTIFIED DATA - HEAT RECOVERY, -230V/60HZ/3PH, 460V/60HZ/3PH**

Product #	Capacity (Tons)	IEER Non-Ducted	IEER Ducted	IEER Mixed	SCHE Non-Ducted	SCHE Ducted	SCHE Mixed	COP @ 47°F Non-Ducted	COP @ 47°F Ducted	COP @ 47°F Mixed	COP @ 17°F Non-Ducted	COP @ 17°F Ducted	COP @ 17°F Mixed	EER Non-Ducted	EER Ducted	EER Mixed
REYQ72AA	6	28.00	23.00	25.50	26.10	22.00	24.05	4.35	3.58	3.97	2.50	2.40	2.45	15.70	12.80	14.25
REYQ96AA	8	30.00	25.30	27.65	26.10	21.10	23.60	4.30	3.56	3.93	2.48	2.25	2.37	14.60	12.80	13.70
REYQ120AA	10	27.50	23.50	25.50	26.10	22.20	24.15	4.00	3.48	3.74	2.38	2.25	2.32	13.20	12.40	12.80
REYQ144AA	12	26.50	22.50	24.50	25.60	22.10	23.85	3.80	3.35	3.58	2.20	2.10	2.15	12.50	12.00	12.25
REYQ168AA	14	24.00	21.40	22.70	25.60	22.30	23.95	3.50	3.20	3.35	2.10	2.10	2.10	11.50	11.10	11.30
REYQ192AA	16	24.00	21.00	22.50	26.60	22.80	24.70	3.85	3.45	3.65	2.05	2.05	2.05	12.30	11.50	11.90
REYQ216AA	18	23.00	20.50	21.75	25.50	21.90	23.70	3.70	3.25	3.48	2.05	2.05	2.05	11.50	11.00	11.25
REYQ240AA	20	21.60	19.70	20.65	25.60	21.80	23.70	3.45	3.20	3.33	2.05	2.05	2.05	11.00	10.80	10.90
REYQ264AA	22	23.90	19.20	21.55	26.20	18.20	22.20	3.70	3.20	3.45	2.35	2.10	2.23	12.00	10.60	11.30
REYQ288AA	24	23.20	19.30	21.25	23.40	20.00	21.70	3.60	3.27	3.44	2.41	2.13	2.27	12.00	11.00	11.50
REYQ312AA	26	22.80	19.20	21.00	24.40	20.80	22.60	3.60	3.25	3.43	2.35	2.10	2.23	11.30	10.80	11.05
REYQ336AA	28	22.10	18.60	20.35	23.40	19.80	21.60	3.60	3.23	3.42	2.20	2.10	2.15	10.50	10.60	10.55
REYQ360AA	30	21.00	18.20	19.60	23.00	19.40	21.20	3.60	3.21	3.41	2.05	2.05	2.05	11.50	10.70	11.10
REYQ384AA	32	22.00	18.80	20.40	22.00	17.00	19.50	3.40	3.25	3.33	2.05	2.05	2.05	10.70	10.50	10.60
REYQ408AA	34	21.50	18.40	19.95	21.90	18.40	20.15	3.40	3.25	3.33	2.05	2.05	2.05	10.70	10.50	10.60
REYQ432AA	36	21.10	18.10	19.60	20.30	18.20	19.25	3.40	3.25	3.33	2.05	2.05	2.05	10.70	10.10	10.40
REYQ456AA	38	20.20	17.50	18.85	18.90	18.00	18.45	3.40	3.25	3.33	2.05	2.05	2.05	9.90	9.80	9.85
REYQ480AA	40	19.40	17.20	18.30	16.90	16.50	16.70	3.40	3.25	3.33	2.05	2.05	2.05	9.70	9.60	9.65

Certified efficiency data in accordance with ANSI/AHRI Standard 1230 2014, "Performance Rating of Variable Refrigerant Flow Multi-Split Air Conditioning and Heat Pump Equipment" for the VRV series. The VRV EMERION series has been designed and optimized to meet or exceed the latest minimum efficiency requirements in 10 C.F.R. Part 431 as determined by the U.S. Department of Energy (DOE) and baseline efficiencies as defined by ASHRAE 90.1 2016. Systems under 65MBH are currently certified to AHRI 210/240. IEER ratings are as defined in ASHRAE 90.1 2016.

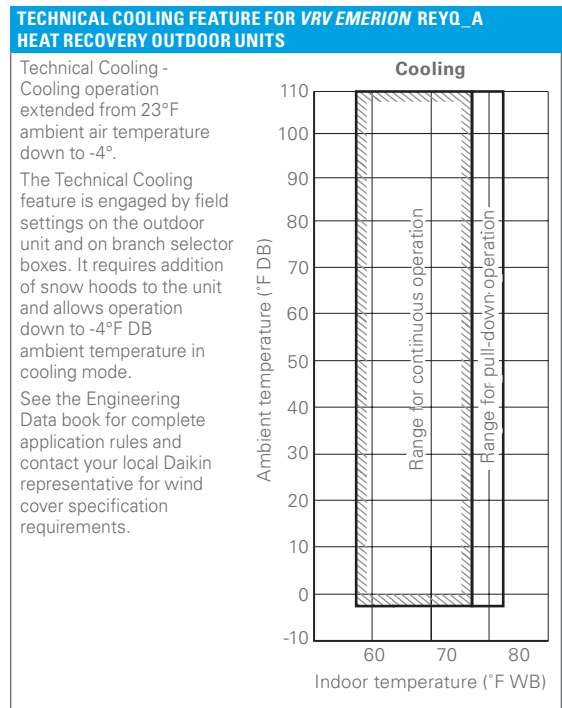
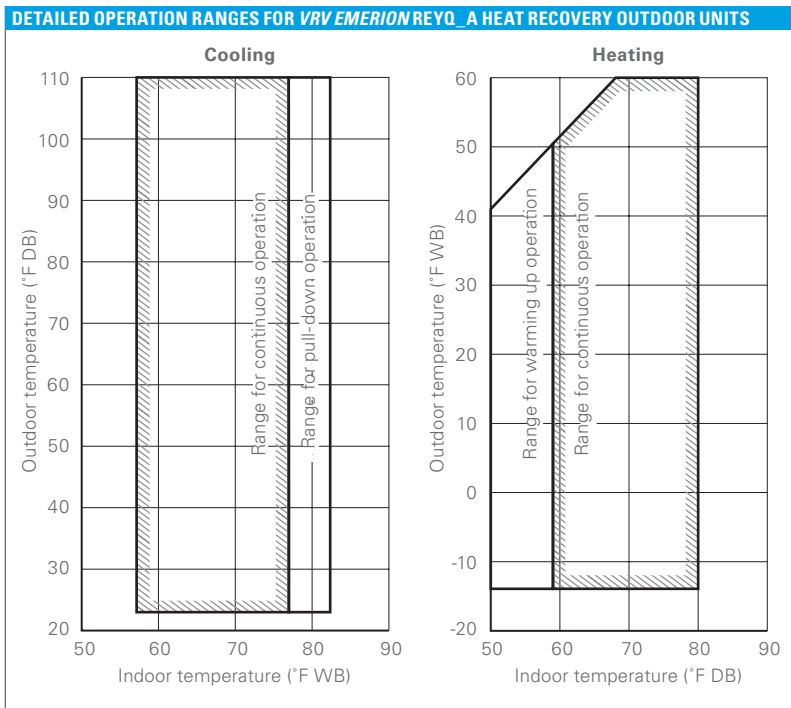

# VRV EMERION

## Air-Cooled Heat Recovery (cont)



### TECHNICAL DATA FOR VRV EMERION - AATJA/AAYDA HEAT RECOVERY OUTDOOR UNITS

		6 Ton	8 Ton	10 Ton	12 Ton	14 Ton	16 Ton	18 Ton	20 Ton	
Model	208-230V/3Ph/60Hz	REYQ72AATJB	REYQ96AATJB	REYQ120AATJB	REYQ144AATJB	REYQ168AATJB	REYQ192AATJB	REYQ216AATJB	REYQ240AATJB	
	460V/3Ph/60Hz	REYQ72AAYDB	REYQ96AAYDB	REYQ120AAYDB	REYQ144AAYDB	REYQ168AAYDB	REYQ192AAYDB	REYQ216AAYDB	REYQ240AAYDB	
	Combination									
Performance	Rated Cooling Capacity	BTU/h	69,000	92,000	114,000	138,000	160,000	184,000	206,000	228,000
	Rated Heating Capacity	BTU/h	77,000	103,000	129,000	154,000	180,000	206,000	232,000	256,000
	Operation Range Cooling	°F (°C) DB	-4* – 122 (-20* – 50)							
	Operation Range Heating	°F (°C) WB	-13 – 60 (-25 – 15.6)							
	Sound Pressure	dB(A)	58	61	61	65	65	67	68	69
	Airflow	CFM	6200	8965	8965	9675	9675	13650	14505	14505
	Fan ESP, Standard/Max	in. W.G.	0.12 / 0.32							
Compressor	Compressors, all inverter	Qty	1	2						
	Revolutions per minute	RPM	4212	4482 + 4482	5934 + 5934	5496 + 5496	6684 + 6684	5586 + 5586	6294 + 6294	7272 + 7272
	Capacity Control Range	%	7-100	4-100	3-100	3-100	2-100	4-100	3-100	3-100
Refrigerant Piping, Layout	Maximum Vertical Pipe Length Above Unit	ft.	164 (361 With Field Setting)*							
	Maximum Vertical Pipe Length Below Unit	ft.	130 (361 With Field Setting)*							
	Maximum Vertical Pipe Length Between IDU	ft.	100							
	Maximum Actual Pipe Length	ft.	541							
	Maximum Equivalent Pipe Length	ft.	620							
	Maximum Total Pipe Length	ft.	3,280							
Refrigerant Piping, Connections	Liquid Pipe, Main Line	in.	3/8	3/8	1/2	1/2	5/8	5/8	5/8	5/8
	Suction Gas Pipe, Main Line	in.	3/4	7/8	1-1/8	1-1/8	1-1/8	1-1/8	1-1/8	1-3/8
	Discharge Gas Pipe, Main Line	in.	5/8	3/4	3/4	7/8	7/8	1-1/8	1-1/8	1 1/8
Connection Ratio	Standard Connectable Indoor Unit Ratio	%	50 - 200 <sup>1</sup>							
	Maximum Number of Indoor Units	Qty	12	16	20	25	29	33	37	41
Electrical	Maximum Overcurrent Protection, MOP (208-230V / 460V)	A	30 / 15	35 / 20	40 / 20	50 / 25	60 / 25	60 / 30	70 / 30	80 / 40
	Minimum Circuit Amps, MCA (208-230V / 460V)	A	27.3 / 12.4	34.1 / 16.4	36.5 / 16.6	47.8 / 21.3	54.9 / 24.9	59.8 / 28.3	67.2 / 29.9	73.7 / 33.4
	Compressor Rated Load Amps, (208-230V / 460V)	A	11.1 / 5.1	7.6 + 7.6 / 3.4 + 3.5	10.5 + 10.6 / 4.8 + 4.8	10.0 + 15.8 / 4.5 + 7.2	12.5 + 20.0 / 5.7 + 9.1	16.6 + 16.6 / 7.5 + 7.6	20.0 + 20.0 / 9.1 + 9.1	24.3 + 24.4 / 11.0 + 11.1
Unit	Factory Refrigerant Charge	lbs.	23.4	25.8						
	Weight (208-230V / 460V)	lbs.	509 / 525	710 / 725	712 / 728	785 / 800	787 / 802	957 / 972	957 / 972	957 / 972
	Dimensions (H x W x D)	in.	65-3/8 x 36-5/8 x 30-1/8	65-3/8 x 48-13/16 x 30-1/8				65-3/8 x 68-7/8 x 30-1/8		

<sup>1</sup>Varies based on indoor model selected \*Refer to engineering and installation manuals for rules and conditions



	22 Ton	24 Ton	26 Ton	28 Ton	30 Ton	32 Ton	34 Ton	36 Ton	38 Ton	40 Ton
	REYQ264AATJB	REYQ288AATJB	REYQ312AATJB	REYQ336AATJB	REYQ360AATJB	REYQ384AATJB	REYQ408AATJB	REYQ432AATJB	REYQ456AATJB	REYQ480AATJB
	REYQ264AAYDB	REYQ288AAYDB	REYQ312AAYDB	REYQ336AAYDB	REYQ360AAYDB	REYQ384AAYDB	REYQ408AAYDB	REYQ432AAYDB	REYQ456AAYDB	REYQ480AAYDB
	1 x REYQ120AA 1 x REYQ144AA	2 x REYQ144AA	1 x REYQ144AA 1 x REYQ168AA	2 x REYQ168AA	1 x REYQ168AA 1 x REYQ192AA	2 x REYQ192AA	1 x REYQ192AA 1 x REYQ216AA	2 x REYQ216AA	1 x REYQ216AA 1 x REYQ240AA	2 x REYQ240AA
	252,000	274,000	296,000	320,000	342,000	364,000	388,000	410,000	434,000	456,000
	282,000	294,000	320,000	338,000	376,000	386,000	394,000	404,000	414,000	424,000
	-4* - 122 (-20* - 50)									
	-13 - 60 (-25 - 15.6)									
	67	69	69	69	70	71	71	72	72	73
	8965 + 9675	9675 + 9675	9675 + 9675	9675 + 9675	9675 + 13650	13650 + 13650	13650 + 14505	14505 + 14505	14505 + 14505	14505 + 14505
	0.12 / 0.32									
	2 + 2									
	(5934 + 5934) + (5496 + 5496)	(5496 + 5496) + (5496 + 5496)	(5496 + 5496) + (6684 + 6684)	(6684 + 6684) + (6684 + 6684)	(6684 + 6684) + (5586 + 5586)	(5586 + 5586) + (5586 + 5586)	(5586 + 5586) + (6294 + 6294)	(6294 + 6294) + (6294 + 6294)	(6294 + 6294) + (7272 + 7272)	(7272 + 7272) + (7272 + 7272)
	1-100	1-100	1-100	1-100	1-100	1-100	1-100	1-100	1-100	1-100
	164 (361 With Field Setting)*									
	130 (361 With Field Setting)*									
	100									
	541									
	620									
	3280									
	3/4	3/4	3/4	3/4	3/4	3/4	3/4	3/4	3/4	3/4
	1-3/8	1-3/8	1-3/8	1-3/8	1-5/8	1-5/8	1-5/8	1-5/8	1-5/8	1-5/8
	1-1/8	1-1/8	1-1/8	1-1/8	1-3/8	1-3/8	1-3/8	1-3/8	1-3/8	1-3/8
	50 - 200 <sup>1</sup>									
	45	49	54	58	62	64				
	40 + 50 / 20 + 25	50 + 50 / 25 + 25	50 + 60 / 25 + 25	60 + 60 / 25 + 25	60 + 60 / 25 + 30	60 + 60 / 30 + 30	60 + 70 / 30 + 30	70 + 80 / 30 + 30	70 + 80 / 30 + 40	80 + 80 / 40 + 40
	36.5 + 47.8 / 16.6 + 21.3	47.8 + 47.8 / 21.3 + 21.3	47.8 + 54.9 / 21.3 + 24.9	54.9 + 54.9 / 24.9 + 24.9	54.9 + 59.8 / 24.9 + 28.3	59.8 + 59.8 / 28.3 + 28.3	59.8 + 67.2 / 28.3 + 29.9	67.2 + 67.2 / 29.9 + 29.9	67.2 + 73.7 / 29.9 + 33.4	73.7 + 73.7 / 33.4 + 33.4
	(10.5 + 10.6) + (10.0 + 15.8) / (4.8 + 4.8) + (4.5 + 7.2)	(10.0 + 15.8) + (10.0 + 15.8) / (4.5 + 7.2) + (4.5 + 7.2)	(10.0 + 15.8) + (12.5 + 20.0) / (4.5 + 7.2) + (5.7 + 9.1)	(12.5 + 20.0) + (12.5 + 20.0) / (5.7 + 9.1) + (5.7 + 9.1)	(12.5 + 20.0) + (16.6 + 16.6) / (5.7 + 9.1) + (7.5 + 7.6)	(16.6 + 16.6) + (16.6 + 16.6) / (7.5 + 7.6) + (7.5 + 7.6)	(16.6 + 16.6) + (20.0 + 20.0) / (7.5 + 7.6) + (9.1 + 9.1)	(20.0 + 20.0) + (20.0 + 20.0) / (9.1 + 9.1) + (9.1 + 9.1)	(20.0 + 20.0) + (24.3 + 24.3) / (9.1 + 9.1) + (11.0 + 11.1)	(24.3 + 24.3) + (24.3 + 24.4) / (11.0 + 11.1) + (11.0 + 11.1)
	25.8 + 25.8									
	712 + 785 / 728 + 800	785 + 785 / 800 + 800	785 + 787 / 800 + 802	787 + 787 / 802 + 802	787 + 957 / 802 + 972	957 + 957 / 972 + 972				
	(65-3/8 x 48-13/16 x 30-1/8) + (65-3/8 x 48-13/16 x 30-1/8)				(65-3/8 x 48-13/16 x 30-1/8) + (65-3/8 x 68-7/8 x 30-1/8)		(65-3/8 x 68-7/8 x 30-1/8) + (65-3/8 x 68-7/8 x 30-1/8)			

# VRV EMERION

## Air-Cooled Heat Pump



Daikin *VRV EMERION* is available in single and dual-module lineups. The introduction of new 16-20 T single modules allows a system capacity of up to 40 Tons with just two modules. This helps reduce the overall space required for mechanical equipment and optimizes total project costs.

### Features and Benefits

- » New Simple and Stylish design with expanded line up with single module units from 6-20T and dual-modules up to 40T
- » Space-saving 16 - 20 T single module units provide up to 34% footprint and up to 500 lbs./unit weight reduction compared to previous series<sup>2</sup>
- » High energy efficiency with IEERs up to 28.5 delivers up to 30% efficiency increase
- » Year-round comfort and energy saving with Daikin's Variable Refrigerant Temperature Technology (VRT)
- » Heating down to -13°F as standard and high heating capacities at 17°F make it an ideal choice for all-electric heat pump solutions
- » Hot gas defrost circuit allows for installation without base pan heater
- » High dust moisture protection with an IP55 rated sealed E-box
- » Dual-Fuel ready with connectivity to Daikin communicating gas furnace or all-electric heat pump heating for optimized operational cost based on utility rates
- » Increased piping lengths of up to 361 ft. vertical separation between ODU and IDU provide additional application flexibility compared to previous *VRV* systems<sup>1</sup>
- » Design flexibility to enlarge system from single to a dual-module without changes to installed main pipe sizes for phased installation or tenant fit-out buildings
- » Local code compliance-ready from factory via alignment with compliance needs, such as OSHPD Seismic, Miami Dade Wind, and Chicago Pressure relief code
- » Reduced wiring costs with up to 27.4% reduction in MCA values compared to previous series
- » Engineered for ease of installation and service with three-segment panel design
- » Factory ships with increase space for easy field piping connection to service valves



- » Built-in data recorder to store up to 40 minutes of operational data
- » Integrates with new Daikin *HERO* ecosystem, an IoT-based remote monitoring and diagnostics platform
- » Connect non standard *VRV* terminal units and AHUs with Daikin *VRV EMERION* leveraging Daikin Air Handling Unit Integration Kit to extend benefits of inverter technology to custom terminal units and AHUs. A kit consists of One Control Box and One EEV box. Offered via EKEQMCBAV3-US and EKEQFCBAV3-US.

<sup>1</sup> Refer to engineering and installation manuals for application rules.

<sup>2</sup> Model specific; check product specification for details.



\* Complete commercial warranty details available from your local distributor or manufacturer's representative or at [www.daikincomfort.com](http://www.daikincomfort.com).



**VRV EMERION CERTIFIED DATA - HEAT PUMP, -230V/60HZ/3PH, 460V/60HZ/3PH**

Product #	Capacity (Tons)	IEER Non-Ducted	IEER Ducted	IEER Mixed	COP @ 47°F Ducted	COP @ 47°F Ducted	COP @ 47°F Mixed	COP @ 17°F Non-Ducted	COP @ 17°F Ducted	COP @ 17°F Mixed	EER Non-Ducted	EER Ducted	EER Mixed
RXYQ72AA	6	27.00	21.40	24.20	4.00	3.54	3.77	2.49	2.42	2.46	15.20	13.00	14.10
RXYQ96AA	8	28.50	24.80	26.65	4.10	3.52	3.81	2.53	2.42	2.48	14.30	12.80	13.55
RXYQ120AA	10	26.60	23.40	25.00	3.77	3.43	3.60	2.46	2.42	2.44	12.60	12.00	12.30
RXYQ144AA	12	25.40	22.90	24.15	3.70	3.36	3.53	2.18	2.12	2.15	12.40	11.70	12.05
RXYQ168AA	14	23.40	21.20	23.30	3.40	3.33	3.37	2.18	2.12	2.15	11.20	11.00	11.10
RXYQ192AA	16	23.60	21.20	22.40	3.66	3.44	3.55	2.22	2.12	2.17	11.60	11.60	11.60
RXYQ216AA	18	22.20	21.00	21.60	3.62	3.32	3.47	2.18	2.12	2.15	11.01	10.90	10.10
REYQ240AA	20	21.80	19.60	20.70	3.34	3.20	3.27	2.16	2.12	2.14	11.00	10.60	10.80
REYQ264AA	22	22.60	19.20	20.90	3.50	3.24	3.37	2.33	2.12	2.23	11.20	10.00	10.60
REYQ288AA	24	22.40	19.20	20.80	3.50	3.31	3.41	2.41	2.12	2.27	11.40	10.40	10.90
REYQ312AA	26	21.80	19.20	20.50	3.50	3.22	3.36	2.35	2.12	2.24	10.70	10.20	10.45
REYQ336AA	28	21.40	18.50	19.95	3.50	3.20	3.35	2.18	2.12	2.15	10.10	10.20	10.15
REYQ360AA	30	20.40	18.50	19.45	3.50	3.20	3.35	2.14	2.12	2.13	11.00	10.10	10.55
REYQ384AA	32	21.40	18.80	20.10	3.35	3.24	3.30	2.18	2.12	2.15	10.20	10.10	10.15
REYQ408AA	34	21.30	18.10	19.70	3.35	3.24	3.30	2.18	2.12	2.15	10.20	9.80	9.85
REYQ432AA	36	20.60	17.20	18.90	3.35	3.24	3.30	2.18	2.12	2.15	10.20	9.50	9.85
REYQ456AA	38	19.80	16.80	18.30	3.30	3.22	3.26	2.18	2.12	2.15	9.60	9.50	9.55
REYQ480AA	40	19.00	16.40	18.40	3.20	3.20	3.20	2.18	2.12	2.15	9.60	9.50	9.55

Certified efficiency data in accordance with ANSI/AHRI Standard 1230 2014, "Performance Rating of Variable Refrigerant Flow Multi-Split Air Conditioning and Heat Pump Equipment" for the VRV series. The VRV EMERION series has been designed and optimized to meet or exceed the latest minimum efficiency requirements in 10 C.F.R. Part 431 as determined by the U.S. Department of Energy (DOE) and baseline efficiencies as defined by ASHRAE 90.1 2016. Systems under 65MBH are currently certified to AHRI 210/240. IEER ratings are as defined in ASHRAE 90.1 2016.

**DETAILED OPERATION RANGES FOR VRV EMERION REYO\_A HEAT RECOVERY OUTDOOR UNITS**

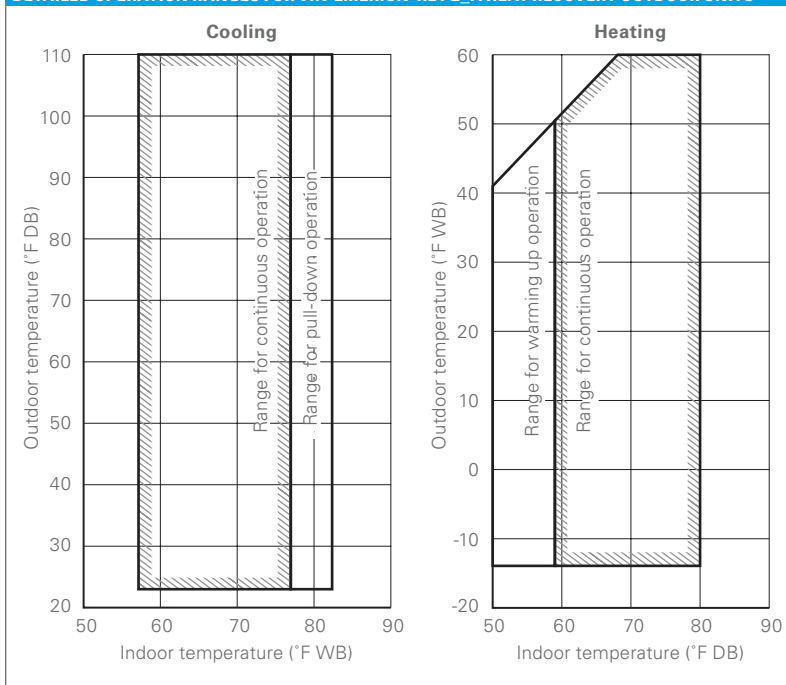

**TECHNICAL COOLING FEATURE FOR VRV EMERION REYO\_A HEAT RECOVERY OUTDOOR UNITS**

**Technical Cooling -**  
Cooling operation extended from 23°F ambient air temperature down to -4°.

The Technical Cooling feature is engaged by field settings on the outdoor unit and on branch selector boxes. It requires addition of snow hoods to the unit and allows operation down to -4°F DB ambient temperature in cooling mode.

See the Engineering Data book for complete application rules and contact your local Daikin representative for wind cover specification requirements.

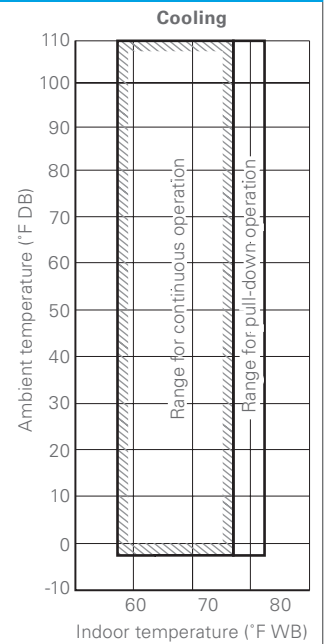

# VRV EMERION

## Air-Cooled Heat Pump (cont)



### TECHNICAL DATA FOR VRV EMERION - AATJA/AAYDA HEAT PUMP OUTDOOR UNITS

		6 Ton	8 Ton	10 Ton	12 Ton	14 Ton	16 Ton	18 Ton	20 Ton	
Model	208-230V/3Ph/60Hz	RXYQ72AATJB	RXYQ96AATJB	RXYQ120AATJB	RXYQ144AATJB	RXYQ168AATJB	RXYQ192AATJB	RXYQ216AATJB	RXYQ240AATJB	
	460V/3Ph/60Hz	RXYQ72AAYDB	RXYQ96AAYDB	RXYQ120AAYDB	RXYQ144AAYDB	RXYQ168AAYDB	RXYQ192AAYDB	RXYQ216AAYDB	RXYQ240AAYDB	
	Combination									
Performance	Rated Cooling Capacity	BTU/h	69,000	92,000	114,000	138,000	160,000	184,000	206,000	228,000
	Rated Heating Capacity	BTU/h	77,000	103,000	126,000	154,000	180,000	206,000	232,000	248,000
	Operation Range Cooling	°F (°C) DB	23 – 122 (-5 – 50)							
	Operation Range Heating	°F (°C) WB	-13 – 60 (-25 – 15.6)							
	Sound Pressure	dB(A)	58	61	61	65	65	67	68	69
	Airflow	CFM	6200	8965	8965	9675	9675	13650	14505	14505
	Fan ESP, Standard/Max	in. W.G.	0.12 / 0.32							
Compressor	Compressors, all inverter	Qty	1	2						
	Revolutions per minute	RPM	4212	4482 + 4482	5934 + 5934	5496 + 5496	6684 + 6684	5586 + 5586	6294 + 6294	7272 + 7272
	Capacity Control Range	%	7-100	4-100	3-100	3-100	2-100	4-100	3-100	3-100
Refrigerant Piping, Layout	Maximum Vertical Pipe Length Above Unit	ft.	164 (361 With Field Setting)*							
	Maximum Vertical Pipe Length Below Unit	ft.	130 (361 With Field Setting)*							
	Maximum Vertical Pipe Length Between IDU	ft.	98							
	Maximum Actual Pipe Length	ft.	540							
	Maximum Equivalent Pipe Length	ft.	623							
	Maximum Total Pipe Length	ft.	3280							
Refrigerant Piping, Connections	Liquid Pipe, Main Line	in.	3/8	3/8	1/2	1/2	5/8	5/8	5/8	5/8
	Suction Gas Pipe, Main Line	in.	3/4	7/8	1-1/8	1-1/8	1-1/8	1-1/8	1-1/8	1-3/8
Connection Ratio	Standard Connectable Indoor Unit Ratio	%	50 - 200 <sup>1</sup>							
	Maximum Number of Indoor Units	Qty	12	16	20	25	29	33	37	41
Electrical	Maximum Overcurrent Protection, MOP (208-230V / 460V)	A	30 / 15	35 / 20	40 / 20	50 / 25	60 / 30 (25 <sup>2</sup> )	60 / 35 (30 <sup>2</sup> )	70 / 35 (30 <sup>2</sup> )	80 / 40
	Minimum Circuit Amps, MCA (208-230V / 460V)	A	27.3 / 12.4	34.1 / 16.4	36.5 / 16.6	47.8 / 21.3	54.9 / 24.9	59.8 / 28.3	67.2 / 29.9	73.7 / 33.4
	Compressor Rated Load Amps, (208-230V / 460V)	A	11.1 / 5.1	7.6 + 7.6 / 3.4 + 3.5	10.5 + 10.6 / 4.8 + 4.8	10.0 + 15.8 / 4.5 + 7.2	12.5 + 20.0 / 5.7 + 9.1	16.6 + 16.6 / 7.5 + 7.6	20.0 + 20.0 / 9.1 + 9.1	24.3 + 24.4 / 11.0 + 11.1
Unit	Factory Refrigerant Charge	lbs.	15.2	24.9	25.4	25.8	25.8	25.8	25.8	25.8
	Weight (208-230V / 460V)	lbs.	496 / 507	683 / 694	683 / 694	750 / 761	750 / 761	904 / 915	904 / 915	904 / 915
	Dimensions (H x W x D)	in.	65-3/8 x 36-5/8 x 30-1/8	65-3/8 x 48-13/16 x 30-1/8				65-3/8 x 68-7/8 x 30-1/8		

<sup>1</sup>Varies based on indoor model selected <sup>2</sup>UL 60335-2-40 calculated MOP values \*Refer to engineering and installation manuals for rules and conditions





	22 Ton	24 Ton	26 Ton	28 Ton	30 Ton	32 Ton	34 Ton	36 Ton <sup>2</sup>	38 Ton	40 Ton
	RXYQ264AATJB	RXYQ288AATJB	RXYQ312AATJB	RXYQ336AATJB	RXYQ360AATJB	RXYQ384AATJB	RXYQ408AATJB	RXYQ432AATJB	RXYQ456AATJB	RXYQ480AATJB
	RXYQ264AAYDB	RXYQ288AAYDB	RXYQ312AAYDB	RXYQ336AAYDB	RXYQ360AAYDB	RXYQ384AAYDB	RXYQ408AAYDB	RXYQ432AAYDB	RXYQ456AAYDB	RXYQ480AAYDB
	1 x RXYQ120AA 1 x RXYQ144AA	2 x RXYQ144AA	1 x RXYQ144AA 1 x RXYQ168AA	2 x RXYQ168AA	1 x RXYQ168AA 1 x RXYQ192AA	2 x RXYQ192AA	1 x RXYQ192AA 1 x RXYQ216AA	2 x RXYQ216AA	1 x RXYQ216AA 1 x RXYQ240AA	2 x RXYQ240AA
	252,000	274,000	296,000	320,000	342,000	364,000	388,000	410,000	434,000	456,000
	282,000	294,000	320,000	338,000	376,000	386,000	394,000	404,000	414,000	424,000
	23 – 122 (-5 – 50)									
	-13 – 60 (-25 – 15.6)									
	67	69	69	69	70	71	71	72	72	73
	8965 + 9935	9935 + 9935	9935 + 9935	9935 + 9935	9935 + 13665	13665 + 13665	13665 + 14510	14510 + 14510	14510 + 14510	14510 + 14510
	0.12 / 0.32									
	2 + 2									
	(5934 + 5934) + (5496 + 5496)	(5496 + 5496) + (5496 + 5496)	(5496 + 5496) + (6684 + 6684)	(6684 + 6684) + (6684 + 6684)	(6684 + 6684) + (5586 + 5586)	(5586 + 5586) + (5586 + 5586)	(5586 + 5586) + (6294 + 6294)	(6294 + 6294) + (6294 + 6294)	(6294 + 6294) + (7272 + 7272)	(7272 + 7272) + (7272 + 7272)
	1-100	1-100	1-100	1-100	1-100	1-100	1-100	1-100	1-100	1-100
	164 (361 With Field Setting)*									
	130 (361 With Field Setting)*									
	98									
	540									
	623									
	3280									
	3/4	3/4	3/4	3/4	3/4	3/4	3/4	3/4	3/4	3/4
	1-3/8	1-3/8	1-3/8	1-3/8	1-5/8	1-5/8	1-5/8	1-5/8	1-5/8	1-5/8
	50 - 200'									
	45	49	54	58	62	64				
	40 + 50 / 20 + 25	50 + 50 / 25 + 25	50 + 60 / 25 + 30 (25 + 25 <sup>2</sup> )	60 + 60 / 30 + 30 (25 <sup>2</sup> + 25 <sup>2</sup> )	60 + 60 / 30 + 35 (25 <sup>2</sup> + 30 <sup>2</sup> )	60 + 60 / 35 + 35 (30 <sup>2</sup> + 30 <sup>2</sup> )	60 + 70 / 35 + 35 (30 <sup>2</sup> + 30 <sup>2</sup> )	70 + 70 / 35 + 35 (30 <sup>2</sup> + 30 <sup>2</sup> )	70 + 80 / 35 + 40 (30 <sup>2</sup> + 40)	80 + 80 / 40 + 40
	36.5 + 47.8 / 16.6 + 21.3	47.8 + 47.8 / 21.3 + 21.3	47.8 + 54.9 / 21.3 + 24.9	54.9 + 54.9 / 24.9 + 24.9	54.9 + 59.8 / 24.9 + 28.3	59.8 + 59.8 / 28.3 + 28.3	59.8 + 67.2 / 28.3 + 29.9	67.2 + 67.2 / 29.9 + 29.9	67.2 + 73.7 / 29.9 + 33.4	73.7 + 73.7 / 33.4 + 33.4
	(10.5 + 10.6) + (10.0 + 15.8) / (4.8 + 4.8) + (4.5 + 7.2)	(10.0 + 15.8) + (10.0 + 15.8) / (4.5 + 7.2) + (4.5 + 7.2)	(10.0 + 15.8) + (12.5 + 20.0) / (4.5 + 7.2) + (5.7 + 9.1)	(12.5 + 20.0) + (12.5 + 20.0) / (5.7 + 9.1) + (5.7 + 9.1)	(12.5 + 20.0) + (16.6 + 16.6) / (5.7 + 9.1) + (7.5 + 7.6)	(16.6 + 16.6) + (16.6 + 16.6) / (7.5 + 7.6) + (7.5 + 7.6)	(16.6 + 16.6) + (20.0 + 20.0) / (7.5 + 7.6) + (9.1 + 9.1)	(20.0 + 20.0) + (20.0 + 20.0) / (9.1 + 9.1) + (9.1 + 9.1)	(20.0 + 20.0) + (24.3 + 24.4) / (9.1 + 9.1) + (11.0 + 11.1)	(24.3 + 24.4) + (24.3 + 24.4) / (11.0 + 11.1) + (11.0 + 11.1)
	25.4 + 25.8	25.8 + 25.8	25.8 + 25.8	25.8 + 25.8	25.8 + 25.8	25.8 + 25.8	25.8 + 25.8	25.8 + 25.8	25.8 + 25.8	25.8 + 25.8
	683 + 750 / 694 + 761	750 + 750 / 761 + 761	750 + 750 / 761 + 761	750 + 750 / 761 + 761	750 + 904 / 761 + 915	904 + 904 / 915 + 915				
	(65-3/8 x 48-13/16 x 30-1/8) + (65-3/8 x 48-13/16 x 30-1/8)				(65-3/8 x 48-13/16 x 30-1/8) + (65-3/8 x 68-7/8 x 30-1/8)	(65-3/8 x 68-7/8 x 30-1/8) + (65-3/8 x 68-7/8 x 30-1/8)				



Daikin VRV EMERION is available in single and dual-module lineups. The introduction of new 16-20 T single modules allows a system capacity of up to 40 Tons with just two modules. This helps reduce the overall space required for mechanical equipment and optimizes total project costs.

### Features and Benefits

- » Low ambient cooling operation down to -4°F (-20°C) with a field setting and the addition of wind covers.
- » Expanded heating operation down to -22°F as standard
- » New D4-Net provides communication that is faster and carries more data volume when compared to the D3-Net.
- » Reduced installation and commissioning time through auto addressing feature with D4 communications protocol
- » R-32 system provides lower global warming potential (GWP) refrigerant along with improved efficiency and requires lower total system charge compared to previous R-410A systems with equivalent capacity and indoor unit match \*\*
- » Designed for increased energy savings through new improved VRT technology with evaporating temperature control at each indoor unit (BS required) \*\*
- » New remote field setting option that allows data retrieval and field setting changes of units on the system from anywhere, without the need for physical access to each room
- » New field setting that allows reuse of R-410A piping network for new R-32 system, eliminating need to replace for retrofit applications
- » Seven segment display to read refrigerant temperatures and pressure on digital display
- » Vertical separation up to 361 FT with field setting \*
- » Continuous heating during defrost capability with single module (16T - 20T) and all dual module systems (22T – 40T)
- » Hot gas defrost circuit eliminates the need for a base pan heater
- » High dust and moisture protection with an IP55 rated sealed electrical box
- » Design flexibility to enlarge system from single to dual-module without changes to installed main pipe sizes for phased installation or tenant fit-out buildings



- » Built-in data recorder to store up to 40 minutes of operational data
- » Integrates with new Daikin HERO ecosystem, an IoT based remote monitoring and diagnostics platform
- » Engineered for ease of installation and service with three-segment panel design
- » Extend benefits of inverter technology to custom terminal units and air handler units (AHUs) through AHU integration kits

\* Refer to engineering and installation manuals for application rules.

\*\* Model specific; check product specification for details.



\* Complete commercial warranty details available from your local distributor or manufacturer's representative or at [www.daikincomfort.com](http://www.daikincomfort.com).



**VRV EMERION CERTIFIED DATA - HEAT RECOVERY, -230V/60HZ/3PH, 460V/60HZ/3PH**

Product #	Capacity (Tons)	IEER Non-Ducted	IEER Ducted	IEER Mixed	SCHE Non-Ducted	SCHE Ducted	SCHE Mixed	COP @ 47°F Non-Ducted	COP @ 47°F Ducted	COP @ 47°F Mixed	COP @ 17°F Non-Ducted	COP @ 17°F Ducted	COP @ 17°F Mixed	EER Non-Ducted	EER Ducted	EER Mixed
REYA72AA	6	23.60	21.20	22.40	19.10	13.20	16.15	3.80	3.60	3.70	2.40	2.40	2.40	12.50	12.40	12.45
REYA96AA	8	24.20	21.20	22.70	18.90	13.60	16.25	3.80	3.60	3.70	2.30	2.25	2.28	12.20	12.00	12.10
REYA120AA	10	23.00	20.20	21.60	19.50	13.20	16.35	3.50	3.50	3.50	2.25	2.25	2.25	11.10	11.10	11.10
REYA144AA	12	22.70	19.70	21.20	19.60	15.00	17.30	3.30	3.35	3.33	2.10	2.10	2.10	11.20	11.00	11.10
REYA168AA	14	21.70	19.00	20.35	21.10	15.60	18.35	3.30	3.30	3.30	2.10	2.10	2.10	10.70	10.70	10.70
REYA192AA	16	22.20	19.80	21.00	21.20	16.40	18.80	3.48	3.40	3.44	2.25	2.25	2.25	11.40	11.30	11.35
REYA216AA	18	21.80	18.70	20.25	21.90	17.40	19.65	3.35	3.35	3.35	2.20	2.20	2.20	10.90	11.00	10.95
REYA240AA	20	20.40	18.00	19.20	21.10	16.40	18.75	3.30	3.30	3.30	2.20	2.20	2.20	10.70	10.70	10.70
REYA264AA	22	21.60	18.40	20.00	21.40	16.10	18.75	3.70	3.25	3.48	2.20	2.20	2.20	11.20	10.20	10.70
REYA288AA	24	21.00	18.40	19.70	20.50	17.20	18.85	3.45	3.25	3.35	2.20	2.10	2.15	11.40	10.40	10.90
REYA312AA	26	20.60	18.00	19.30	21.10	15.20	18.15	3.40	3.20	3.30	2.20	2.10	2.15	10.90	10.20	10.55
REYA336AA	28	19.80	17.70	18.75	20.50	16.10	18.30	3.40	3.20	3.30	2.10	2.10	2.10	9.80	10.00	9.90
REYA360AA	30	18.90	17.40	18.15	19.40	15.10	17.25	3.40	3.20	3.30	2.10	2.10	2.10	10.50	9.70	10.10
REYA384AA	32	20.70	18.00	19.35	15.80	11.60	13.70	3.35	3.20	3.28	2.10	2.10	2.10	10.50	9.90	10.20
REYA408AA	34	19.90	17.20	18.55	14.50	11.70	13.10	3.35	3.20	3.28	2.10	2.10	2.10	10.00	9.70	9.85
REYA432AA	36	18.80	16.80	17.80	12.20	11.50	11.85	3.30	3.20	3.25	2.10	2.10	2.10	9.80	9.30	9.55
REYA456AA	38	18.30	16.20	17.25	10.20	11.00	10.60	3.30	3.20	3.25	2.10	2.10	2.10	9.40	9.00	9.20
REYA480AA	40	18.00	15.80	16.90	9.10	10.00	9.55	3.30	3.20	3.25	2.10	2.10	2.10	8.90	9.00	8.95

Certified efficiency data in accordance with ANSI/AHRI Standard 1230-2023, "Performance Rating of Variable Refrigerant Flow Multi-Split Air Conditioning and Heat Pump Equipment" for the VRV series. The VRV EMERION series has been designed and optimized to meet or exceed the latest minimum efficiency requirements in 10 C.F.R. Part 431 as determined by the U.S. Department of Energy (DOE) and baseline efficiencies as defined by ASHRAE 90.1 2022. Systems under 65MBH are currently certified to AHRI 210/240. IEER ratings are as defined in ASHRAE 90.1 2016.

**DETAILED OPERATION RANGES FOR VRV EMERION REYA\_A HEAT RECOVERY OUTDOOR UNITS**

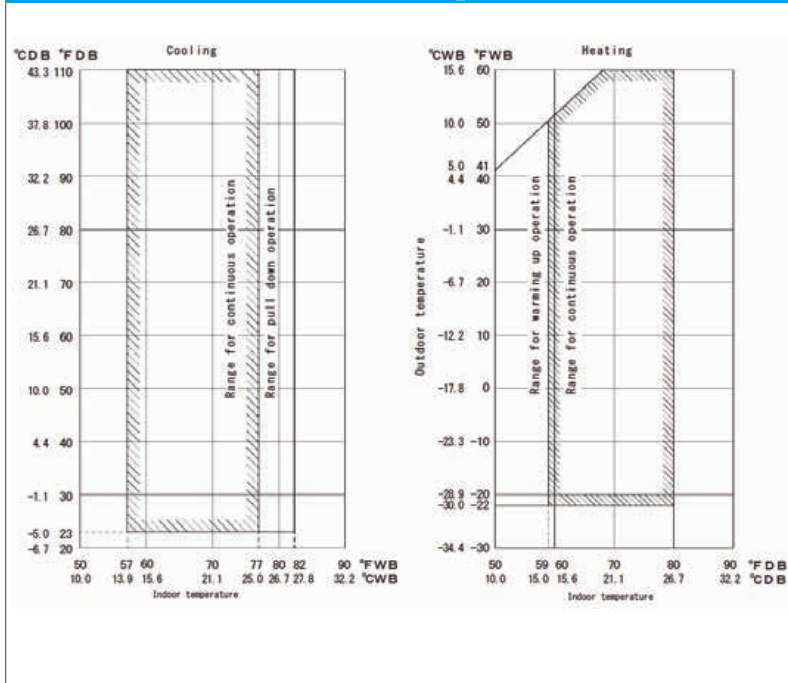

**TECHNICAL COOLING FEATURE FOR VRV EMERION REYA\_A HEAT RECOVERY OUTDOOR UNITS**

Technical Cooling - Cooling operation extended from 23°F ambient air temperature down to -4°. The Technical Cooling feature is engaged by field settings on the outdoor unit, SSOV required. It requires addition of snow hoods to the unit and allows operation down to -4°F DB ambient temperature in cooling mode. See the Engineering Data book for complete application rules and contact your local Daikin representative for wind cover specification requirements.

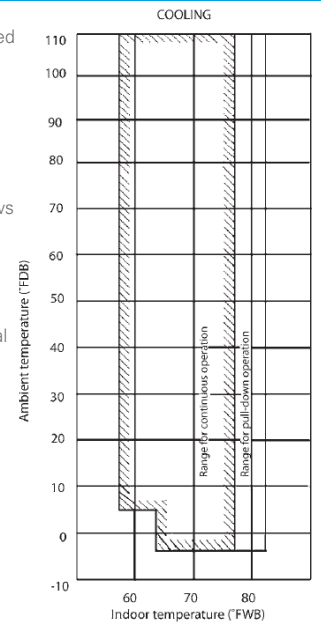



### TECHNICAL DATA FOR R32 VRV EMERION - AATJA/AAYDA HEAT RECOVERY OUTDOOR UNITS (SINGLE MODULES)

		6 Ton	8 Ton	10 Ton	12 Ton	14 Ton	16 Ton	18 Ton	20 Ton	
Model	208-230V/3Ph/60Hz	REYA72AATJA	REYA96AATJA	REYA120AATJA	REYA144AATJA	REYA168AATJA	REYA192AATJA	REYA216AATJA	REYA240AATJA	
	460V/3Ph/60Hz	REYA72AAAYDA	REYA96AAAYDA	REYA120AAAYDA	REYA144AAAYDA	REYA168AAAYDA	REYA192AAAYDA	REYA216AAAYDA	REYA240AAAYDA	
	Combination	--	--	--	--	--	--	--	--	
Performance	Nominal Cooling Capacity	BTU/h	72,000	96,000	119,000	144,000	162,000	192,000	216,000	238,000
	Nominal Heating Capacity	BTU/h	81,000	108,000	135,000	162,000	189,000	216,000	243,000	270,000
	Operation Range Cooling	°F(°C) DB	-4* – 122 (-20* – 50)							
	Operation Range Heating	°F(°C) DB	-22 – 60 (-30 – 15.5)							
	Sound Pressure Level	dB(A)	58	61	61	65	65	67	68	69
	Airflow	CFM	6200	8965	8965	9675	9675	13650	14505	14505
Refrigerant Piping Layout	Maximum Vertical Pipe Length Above IDU Unit	ft.	164 (361 With Field Setting)*							
	Maximum Vertical Pipe Length Below IDU Unit	ft.	130 (361 With Field Setting)*							
	Maximum Vertical Pipe Length Between IDU	ft.	100							
	Maximum Actual Pipe Length	ft.	541							
	Maximum Equivalent Pipe Length	ft.	620							
	Maximum Total Pipe Length	ft.	3280							
Refrigerant Piping	Refrigerant		R32							
	Liquid Pipe (Main Line)	in	3/8	3/8	1/2	1/2	1/2	1/2	1/2	5/8
	Suction Gas Pipe (Main Line)	in	3/4	7/8	7/8	1-1/8	1-1/8	1-1/8	1-1/8	1-1/8
	Discharge Gas Pipe (Main Line)	in	5/8	5/8	3/4	3/4	7/8	7/8	7/8	7/8
Connection Ratio	Connectable Indoor Unit Ratio	%	50 – 2001							
	Maximum Number of Indoor Units	Qty	12	16	20	25	29	33	37	41
Electrical	Maximum OverCurrent Protection, MOP (208-230V / 460V)	A	35 / 20	40 / 20	45 / 25	60 / 30	70 / 30	80 / 35	80 / 40	90 / 40
	Minimum Circuit Amps, MCA (208-230V / 460V)	A	33 / 14.9	34.9 / 17.5	40 / 18.2	50 / 23.3	60.2 / 27.1	64.2 / 30.7	70 / 32.8	79.1 / 35.1
Unit	Outdoor Unit Size (HxWxD)	in	65-3/8 x 36-5/8 x 30-1/8	65-3/8 x 48-13/16 x 30-1/8				65-3/8 x 68-7/8 x 30-1/8		
	Weight (208-230V / 460V)	lbs.	549 / 564	736 / 752	739 / 754	825 / 840	827 / 842	1010 / 1025	1010 / 1025	1010 / 1025

<sup>1</sup>Varies based on indoor model selected \* Refer to engineering and installation manuals for rules and conditions



**TECHNICAL DATA FOR R32 VRV EMERION- AATJA/AAYDA HEAT RECOVERY OUTDOOR UNITS (DUAL MODULES)**

		22 Ton	24 Ton	26 Ton	28 Ton	30 Ton	32 Ton	34 Ton	36 Ton	38 Ton	40 Ton
208-230V/3Ph/60Hz		REYA264AATJA	REYA288AATJA	RXYA312AATJA	REYA336AATJA	REYA360AATJA	REYA384AATJA	REYA408AATJA	REYA432AATJA	REYA456AATJA	REYA480AATJA
460V/3Ph/60Hz		REYA264AAYDA	REYA288AAYDA	RXYA312AAYDA	REYA336AAYDA	REYA360AAYDA	REYA384AAYDA	REYA408AAYDA	REYA432AAYDA	REYA456AAYDA	REYA480AAYDA
Combination		1 x REYA120AA 1 x REYA144AA	2 x REYA144AA	1 x REYA144AA 1 x REYA168AA	2 x REYA168AA	1 x REYA168AA 1 x REYA192AA	2 x REYA192AA	1 x REYA192AA 1 x REYA216AA	2 x REYA216AA	1 x REYA216AA 1 x REYA240AA	2 x REYA240AA
Nominal Cooling Capacity	BTU/h	264,000	286,000	310,000	330,000	358,000	382,000	406,000	430,000	444,000	456,000
Nominal Heating Capacity	BTU/h	297,000	324,000	351,000	378,000	405,000	432,000	459,000	486,000	513,000	540,000
Operation Range Cooling	°F DB	4* – 122 (-20* – 50)									
Operation Range Heating	°F WB	-22 – 60 (-30 – 15.5)									
Sound Pressure Level	dB(A)	67	69	69	69	70	71	71	72	72	73
Airflow	CFM	8965 + 9675	9675 + 9675	9675 + 9675	9675 + 9675	9675 + 13650	13650 + 13650	13650 + 14505	14505 + 14505	14505 + 14505	14505 + 14505
Maximum Vertical Pipe Length Above Unit	ft.	164 (361 With Field Setting)*									
Maximum Vertical Pipe Length Below Unit	ft.	130 (361 With Field Setting)*									
Maximum Vertical Pipe Length Between IDU	ft.	100									
Maximum Actual Pipe Length	ft.	541									
Maximum Equivalent Pipe Length	ft.	620									
Maximum Total Pipe Length	ft.	3280									
Refrigerant		R32									
Liquid Pipe (Main Line)	in	5/8	5/8	5/8	5/8	5/8	5/8	3/4	3/4	3/4	3/4
Suction Gas Pipe (Main Line)	in	1-1/8	1-3/8	1-3/8	1-3/8	1-3/8	1-3/8	1-5/8	1-5/8	1-5/8	1-5/8
Discharge Gas Pipe (Main Line)	in	1-1/8	1-1/8	1-1/8	1-1/8	1-1/8	1-1/8	1-1/8	1-1/8	1-1/8	1-1/8
Connectable Indoor Unit Ratio	%	50 – 2001									
Maximum Number of Indoor Units	Qty	45	49	54	58	62	64				
Maximum OverCurrent Protection, MOP (208-230V / 460V)	A	45 + 60 / 25 + 30	60 + 60 / 30 + 30	60 + 70 / 30 + 30	70 + 70 / 30 + 30	70 + 80 / 30 + 35	80 + 80 / 35 + 35	80 + 80 / 35 + 40	80 + 80 / 40 + 40	80 + 90 / 40 + 40	90 + 90 / 40 + 40
Minimum Circuit Amps, MCA (208-230V / 460V)	A	40 + 50 / 18.2 + 23.3	50 + 50 / 23.2 + 23.3	50 + 60.2 / 23.3 + 27.1	60.2 + 60.2 / 27.1 + 27.1	60.2 + 64.2 / 27.1 + 30.7	64.2 + 64.2 / 30.7 + 30.7	64.2 + 70 / 30.7 + 32.8	70 + 70 / 32.8 + 32.8	70 + 79.1 / 32.8 + 35.1	79.1 + 79.1 / 35.1 + 35.1
Outdoor Unit Size (HxWxD)	in	(65-3/8 x 48-13/16 x 30-1/8) + (65-3/8 x 48-13/16 x 30-1/8)				(65-3/8 x 48-13/16 x 30-1/8) + (65-3/8 x 68-7/8 x 30-1/8)		(65-3/8 x 68-7/8 x 30-1/8) + (65-3/8 x 68-7/8 x 30-1/8)			
Weight (208-230V / 460V)	lbs.	739 + 825 / 754 + 840	825 + 825 / 840 + 840	825 + 827 / 840 + 842	827 + 827 / 842 + 842	827 + 1010 / 842 + 1025	1010 + 1010 / 1025 + 1025				

<sup>1</sup>Varies based on indoor model selected \* Refer to engineering and installation manuals for rules and conditions



Daikin VRV EMERION is available in single and dual-module lineups. The introduction of new 16-20 T single modules allows a system capacity of up to 40 Tons with just two modules. This helps reduce the overall space required for mechanical equipment and optimizes total project costs.

### Features and Benefits

- » Low ambient cooling operation down to -4°F (-20°C) with a field setting and the addition of wind covers. (Only with safety shut off valves for heat pump models)
  - » Expanded heating operation down to -22°F as standard
  - » New D4-Net provides communication that is faster and carries more data volume when compared to the D3-Net.
  - » Reduced installation and commissioning time through auto addressing feature with D4 communications protocol
  - » R-32 system provides lower global warming potential (GWP) refrigerant along with improved efficiency and requires lower total system charge compared to previous R-410A systems with equivalent capacity and indoor unit match\*\*
  - » Designed for increased energy savings through new improved VRT technology with evaporating temperature control at each indoor unit (SSOV required)\*\*
  - » New remote field setting option that allows data retrieval and field setting changes of units on the system from anywhere, without the need for physical access to each room
  - » New field setting that allows reuse of R-410A piping network for new R-32 system, eliminating need to replace for retrofit applications
  - » Seven segment display to read refrigerant temperatures and pressure on digital display
  - » Vertical separation up to 361 FT with field setting\*
  - » Continuous heating during defrost capability with single module (16T - 20T) and all dual module systems (22T – 40T)
  - » Hot gas defrost circuit eliminates the need for a base pan heater
  - » High dust and moisture protection with an IP55 rated sealed electrical box
- » Design flexibility to enlarge system from single to dual-module without changes to installed main pipe sizes for phased installation or tenant fit-out buildings
  - » Built-in data recorder to store up to 40 minutes of operational data
  - » Integrates with new Daikin HERO ecosystem, an IoT based remote monitoring and diagnostics platform
  - » Engineered for ease of installation and service with three-segment panel design
  - » Extend benefits of inverter technology to custom terminal units and air handler units (AHUs) through AHU integration kits

\* Refer to engineering and installation manuals for rules and conditions

\*\* Model specific; check product specification for details





**VRV EMERION CERTIFIED DATA - HEAT PUMP, -230V/60HZ/3PH, 460V/60HZ/3PH**

Product #	Capacity (Tons)	IEER Non-Ducted	IEER Ducted	IEER Mixed	COP @ 47°F Ducted	COP @ 47°F Ducted	COP @ 47°F Mixed	COP @ 17°F Non-Ducted	COP @ 17°F Ducted	COP @ 17°F Mixed	EER Non-Ducted	EER Ducted	EER Mixed
RXYA72AA	6	23.50	21.00	22.25	3.64	3.60	3.62	2.40	2.40	2.40	12.50	12.40	12.45
RXYA96AA	8	24.50	20.80	22.65	3.50	3.40	3.45	2.30	2.25	2.28	12.20	12.00	12.10
RXYA120AA	10	22.80	20.00	21.40	3.40	3.40	3.40	2.25	2.25	2.25	11.10	11.10	11.10
RXYA144AA	12	22.40	19.60	21.00	3.30	3.35	3.33	2.10	2.10	2.10	11.00	11.00	11.00
RXYA168AA	14	21.70	18.80	20.25	3.30	3.30	3.30	2.10	2.10	2.10	10.70	10.70	10.70
RXYA192AA	16	22.40	19.40	20.90	3.48	3.40	3.44	2.24	2.24	2.24	11.40	11.30	11.35
RXYA216AA	18	21.70	18.70	20.20	3.35	3.35	3.35	2.20	2.20	2.20	10.90	11.00	10.95
RXYA240AA	20	20.40	18.00	19.20	3.25	3.25	3.25	2.18	2.18	2.18	10.70	10.70	10.70
RXYA264AA	22	21.60	18.30	19.95	3.40	3.20	3.30	2.20	2.20	2.20	11.00	10.20	10.60
RXYA288AA	24	21.00	18.20	19.60	3.50	3.25	3.38	2.20	2.10	2.15	10.80	10.40	10.60
RXYA312AA	26	20.60	17.70	19.15	3.50	3.20	3.35	2.20	2.10	2.15	10.30	10.10	10.20
RXYA336AA	28	19.00	17.30	18.15	3.50	3.20	3.35	2.10	2.10	2.10	9.40	9.40	9.40
RXYA360AA	30	19.80	17.40	18.60	3.50	3.25	3.38	2.10	2.10	2.10	10.40	9.40	9.90
RXYA384AA	32	20.40	17.80	19.10	3.45	3.25	3.35	2.10	2.10	2.10	10.50	9.90	10.20
RXYA408AA	34	19.90	17.20	18.55	3.45	3.25	3.35	2.10	2.10	2.10	10.10	9.30	9.70
RXYA432AA	36	19.00	16.80	17.90	3.30	3.25	3.28	2.10	2.10	2.10	9.60	9.20	9.40
RXYA456AA	38	19.00	17.00	18.00	3.30	3.25	3.28	2.10	2.10	2.10	9.40	9.20	9.30
RXYA480AA	40	18.40	16.80	17.60	3.25	3.20	3.23	2.10	2.10	2.10	9.40	9.10	9.25

Certified efficiency data in accordance with ANSI/AHRI Standard 1230-2023, "Performance Rating of Variable Refrigerant Flow Multi-Split Air Conditioning and Heat Pump Equipment" for the VRV series. The VRV EMERION series has been designed and optimized to meet or exceed the latest minimum efficiency requirements in 10 C.F.R. Part 431 as determined by the U.S. Department of Energy (DOE) and baseline efficiencies as defined by ASHRAE 90.1 2022. Systems under 65MBH are currently certified to AHRI 210/240. IEER ratings are as defined in ASHRAE 90.1 2016.

**DETAILED OPERATION RANGES FOR VRV EMERION RXYA\_A HEAT RECOVERY OUTDOOR UNITS**

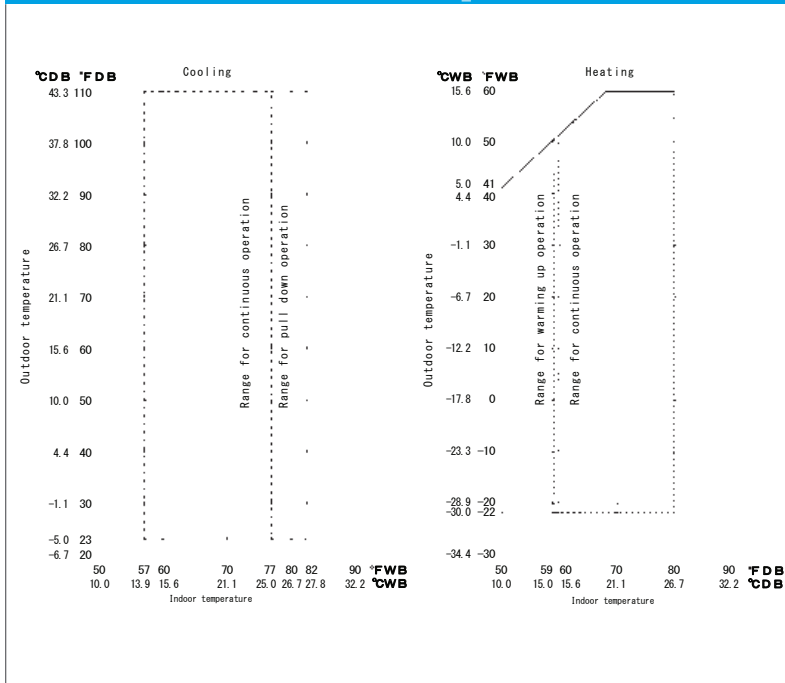

**TECHNICAL COOLING FEATURE FOR VRV EMERION RXYA\_A HEAT RECOVERY OUTDOOR UNITS**

Technical Cooling - Cooling operation extended from 23°F ambient air temperature down to -4°F. The Technical Cooling feature is engaged by field settings on the outdoor unit, SSOV required. It requires addition of snow hoods to the unit and allows operation down to -4°F DB ambient temperature in cooling mode. See the Engineering Data book for complete application rules and contact your local Daikin representative for wind cover specification requirements.

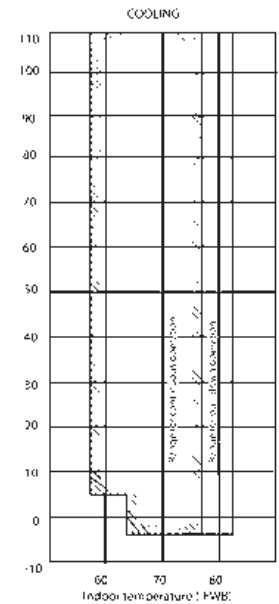



### TECHNICAL DATA FOR R32 VRV EMERION - AATJA/AAYDA HEAT PUMP OUTDOOR UNITS (SINGLE MODULES)

		6 Ton	8 Ton	10 Ton	12 Ton	14 Ton	16 Ton	18 Ton	20 Ton	
Model	208-230V/3Ph/60Hz	RXYA72AATJA	RXYA96AATJA	RXYA120AATJA	RXYA144AATJA	RXYA168AATJA	RXYA192AATJA	RXYA216AATJA	RXYA240AATJA	
	460V/3Ph/60Hz	RXYA72AAYDA	RXYA96AAYDA	RXYA120AAYDA	RXYA144AAYDA	RXYA168AAYDA	RXYA192AAYDA	RXYA216AAYDA	RXYA240AAYDA	
	Combination	--	--	--	--	--	--	--	--	
Performance	Nominal Cooling Capacity	BTU/h	72,000	96,000	119,000	144,000	162,000	192,000	216,000	238,000
	Nominal Heating Capacity	BTU/h	81,000	108,000	135,000	162,000	189,000	216,000	243,000	270,000
	Operation Range Cooling	°F(°C) DB	-4* – 122 (-20* – 50)							
	Operation Range Heating	°F(°C) DB	-22 – 60 (-30 – 15.5)							
	Sound Pressure Level	dB(A)	58	61	61	65	65	67	68	69
	Airflow	CFM	6200	8965	8965	9675	9675	13650	14505	14505
Refrigerant Piping Layout	Maximum Vertical Pipe Length Above IDU Unit	ft.	164 (361 With Field Setting)*							
	Maximum Vertical Pipe Length Below IDU Unit	ft.	130 (361 With Field Setting)*							
	Maximum Vertical Pipe Length Between IDU	ft.	100							
	Maximum Actual Pipe Length	ft.	541							
	Maximum Equivalent Pipe Length	ft.	620							
	Maximum Total Pipe Length	ft.	3280							
Refrigerant Piping	Refrigerant		R32							
	Liquid Pipe (Main Line)	in	3/8	3/8	1/2	1/2	1/2	1/2	1/2	5/8
	Suction Gas Pipe (Main Line)	in	3/4	7/8	7/8	1-1/8	1-1/8	1-1/8	1-1/8	1-1/8
Connection Ratio	Connectable Indoor Unit Ratio	%	50 – 2001							
	Maximum Number of Indoor Units	Qty	12	16	20	25	29	33	37	41
Electrical	Maximum OverCurrent Protection, MOP (208-230V / 460V)	A	35 / 20	40 / 20	45 / 25	60 / 30	70 / 30	80 / 35	80 / 40	90 / 40
	Minimum Circuit Amps, MCA (208-230V / 460V)	A	33 / 14.9	34.9 / 17.5	40 / 18.2	50 / 23.3	60.2 / 27.1	64.2 / 30.7	70 / 32.8	79.1 / 35.1
Unit	Outdoor Unit Size (HxWxD)	in	65-3/8 x 36-5/8 x 30-1/8	65-3/8 x 48-13/16 x 30-1/8				65-3/8 x 68-7/8 x 30-1/8		
	Weight (208-230V / 460V)	lbs.	549 / 564	736 / 752	739 / 754	825 / 840	827 / 842	1010 / 1025	1010 / 1025	1010 / 1025

<sup>1</sup>Varies based on indoor model selected \* Refer to engineering and installation manuals for rules and conditions





**TECHNICAL DATA FOR R32 VRV EMERION - AATJA/AAYDA HEAT PUMP OUTDOOR UNITS (DUAL MODULES)**

		22 Ton	24 Ton	26 Ton	28 Ton	30 Ton	32 Ton	34 Ton	36 Ton	38 Ton	40 Ton
208-230V/3Ph/60Hz		RXYA264AATJA	RXYA288AATJA	RXYA312AATJA	RXYA336AATJA	RXYA360AATJA	RXYA384AATJA	RXYA408AATJA	RXYA432AATJA	RXYA456AATJA	RXYA480AATJA
460V/3Ph/60Hz		RXYA264AAYDA	RXYA288AAYDA	RXYA312AAYDA	RXYA336AAYDA	RXYA360AAYDA	RXYA384AAYDA	RXYA408AAYDA	RXYA432AAYDA	RXYA456AAYDA	RXYA480AAYDA
Combination		1 x RXYA120AA 1 x RXYA144AA	2 x RXYA144AA	1 x RXYA144AA 1 x RXYA168AA	2 x RXYA168AA	1 x RXYA168AA 1 x RXYA192AA	2 x RXYA192AA	1 x RXYA192AA 1 x RXYA216AA	2 x RXYA216AA	1 x RXYA216AA 1 x RXYA240AA	2 x RXYA240AA
Nominal Cooling Capacity	BTU/h	264,000	286,000	310,000	330,000	358,000	382,000	406,000	430,000	444,000	456,000
Nominal Heating Capacity	BTU/h	297,000	324,000	351,000	378,000	405,000	432,000	459,000	486,000	513,000	540,000
Operation Range Cooling	°F DB	4* – 122 (-20* – 50)									
Operation Range Heating	°F WB	-22 – 60 (-30 – 15.5)									
Sound Pressure Level	dB(A)	67	69	69	69	70	71	71	72	72	73
Airflow	CFM	8965 + 9675	9675 + 9675	9675 + 9675	9675 + 9675	9675 + 13650	13650 + 13650	13650 + 14505	14505 + 14505	14505 + 14505	14505 + 14505
Maximum Vertical Pipe Length Above Unit	ft.	164 (361 With Field Setting)*									
Maximum Vertical Pipe Length Below Unit	ft.	130 (361 With Field Setting)*									
Maximum Vertical Pipe Length Between IDU	ft.	100									
Maximum Actual Pipe Length	ft.	541									
Maximum Equivalent Pipe Length	ft.	620									
Maximum Total Pipe Length	ft.	3280									
Refrigerant		R32									
Liquid Pipe (Main Line)	in	5/8	5/8	5/8	5/8	5/8	5/8	3/4	3/4	3/4	3/4
Suction Gas Pipe (Main Line)	in	1-1/8	1-3/8	1-3/8	1-3/8	1-3/8	1-3/8	1-5/8	1-5/8	1-5/8	1-5/8
Connectable Indoor Unit Ratio	%	50 – 2001									
Maximum Number of Indoor Units	Qty	45	49	54	58	62	64				
Maximum OverCurrent Protection, MOP (208-230V / 460V)	A	45 + 60 / 25 + 30	60 + 60 / 30 + 30	60 + 70 / 30 + 30	70 + 70 / 30 + 30	70 + 80 / 30 + 35	80 + 80 / 35 + 35	80 + 80 / 35 + 40	80 + 80 / 40 + 40	80 + 90 / 40 + 40	90 + 90 / 40 + 40
Minimum Circuit Amps, MCA (208-230V / 460V)	A	40 + 50 / 18.2 + 23.3	50 + 50 / 23.2 + 23.3*	50 + 60.2 / 23.3 + 27.1	60.2 + 60.2 / 27.1 + 27.1	60.2 + 64.2 / 27.1 + 30.7	64.2 + 64.2 / 30.7 + 30.7	64.2 + 70 / 30.7 + 32.8	70 + 70 / 32.8 + 32.8	70 + 79.1 / 32.8 + 35.1	79.1 + 79.1 / 35.1 + 35.1
Outdoor Unit Size (HxWxD)	in	(65-3/8 x 48-13/16 x 30-1/8) + (65-3/8 x 48-13/16 x 30-1/8)				(65-3/8 x 48-13/16 x 30-1/8) + (65-3/8 x 68-7/8 x 30-1/8)	(65-3/8 x 68-7/8 x 30-1/8) + (65-3/8 x 68-7/8 x 30-1/8)				
Weight (208-230V / 460V)	lbs.	739 + 825 / 754 + 840	825 + 825 / 840 + 840	825 + 827 / 840 + 842	827 + 827 / 842 + 842	827 + 1010 / 842 + 1025	1010 + 1010 / 1025 + 1025				

<sup>1</sup>Varies based on indoor model selected \* Refer to engineering and installation manuals for rules and conditions

# VRV IV X

## Air-Cooled Heat Recovery



Engineered and assembled in North America, Daikin's VRV IV X Heat Recovery adapts VRV to North American HVAC market needs by expanding the applications in which VRV can be leveraged to solve traditional HVAC challenges. Packed with advanced technology, the VRV IV X is the industry's first 3-phase variable refrigerant flow system with dual-fuel capability. The new series is equipped with features to optimize initial capital required on phased installations and provides ease of service and maintenance.

### Features and Benefits

- » Adapting VRV to North American market needs
  - Industry's first 3-phase variable refrigerant flow system to integrate with communicating gas furnaces.
  - Design flexibility to enlarge system from single to dual module or dual to triple module without change to installed main pipe sizes<sup>1</sup>.
  - Engineered to optimize capital on phased and tenant fit out commercial buildings.
  - Choice of gas furnace or heat pump heating for optimizing operational costs based on utility cost.
  - Year round comfort and energy savings with Variable Refrigerant Temperature (VRT) technology.
- » Technology that matters
  - Engineered with Daikin's patented vapor injection compressor technology.
  - Corrosion resistant up to 1000<sup>+</sup> hours Daikin Blue Fin coating as factory standard.
  - Heat exchanger engineered with a bottom refrigerant circuit that allows installation without base pan heater.
  - Refrigerant cooled inverter technology keeps PCB cool independent of ambient temperature.
- » Engineered for maintenance
  - New service window provides ease of access to the multi-functional display without removing the main electrical panel. The built-in multi-functional display is utilized for commissioning and maintenance and quickly converts to digital gauges to provide refrigerant pressure and temperatures.
  - Multi-functional display eliminates the need to connect gauges during regular maintenance checks.
  - Ease of commissioning with ability to program off site and upload using configurator tool.

## VRV IV X

### Applications:



- Field performable intermittent outdoor fan operation to help minimize snow accumulation on fan blades when the system is in thermal off.
- Seamless integration with T-Series and *Flex Branch Selector* Boxes, M, P, and T-Series indoor units.
- Compatible with the full suite of Daikin VRV controls.
- Outstanding 10-Year Parts Warranty\* as standard.

\* Complete commercial warranty details available from your local distributor or manufacturer's representative or at [www.daikincomfort.com](http://www.daikincomfort.com).

<sup>†</sup> When testing in accordance to ASTM B117 methodology.

<sup>1</sup> Refer to engineering manuals for design rules and pipe sizes.



**VRF IV X CERTIFIED DATA - HEAT RECOVERY, 208-230V/60HZ/3PH, 460V/60HZ/3PH**

Product#	Capacity (Tons)	IEER Non-Ducted	IEER Ducted	IEER Mixed	SCHE Non-Ducted	SCHE Ducted	SCHE Mixed	COP @ 47°F Non-Ducted	COP @ 47°F Ducted	COP @ 47°F Mixed	COP @ 17°F Non-Ducted	COP @ 17°F Ducted	COP @ 17°F Mixed	EER Non-Ducted	EER Ducted	EER Mixed
REYQ72XA	6	25.20	21.30	23.25	26.10	22.00	24.05	4.30	3.68	3.99	2.50	2.25	2.38	15.80	13.90	14.85
REYQ96XA	8	27.80	21.90	24.85	26.40	21.10	23.75	4.23	3.56	3.90	2.63	2.31	2.47	14.60	12.50	13.55
REYQ120XA	10	25.50	22.60	24.05	26.00	22.00	24.00	3.81	3.48	3.65	2.54	2.28	2.41	13.20	12.30	12.75
REYQ144XA	12	23.50	21.60	22.55	25.50	22.00	23.75	3.75	3.42	3.59	2.16	2.12	2.14	11.90	11.60	11.75
REYQ168XA	14	22.30	20.40	21.35	25.50	22.20	23.85	3.55	3.30	3.43	2.08	2.05	2.07	10.70	10.70	10.70
REYQ192XA	16	22.60	21.40	22.00	26.60	22.80	24.70	3.85	3.67	3.76	2.50	2.37	2.44	13.00	13.00	13.00
REYQ216XA	18	23.10	21.70	22.40	25.50	21.90	23.70	3.76	3.52	3.64	2.34	2.20	2.27	12.40	12.30	12.35
REYQ240XA	20	22.20	20.00	21.10	25.60	21.80	23.70	3.68	3.39	3.54	2.34	2.16	2.25	11.60	11.70	11.65
REYQ264XA	22	21.60	18.00	19.80	26.10	18.20	22.15	3.62	3.20	3.41	2.22	2.07	2.15	11.20	10.40	10.80
REYQ288XA	24	21.00	17.90	19.45	23.30	19.90	21.60	3.51	3.20	3.36	2.20	2.06	2.13	11.00	10.30	10.65
REYQ312XA	26	20.40	18.00	19.20	24.30	20.70	22.50	3.56	3.20	3.38	2.09	2.05	2.07	10.10	9.90	10.00
REYQ336XA	28	20.00	17.30	18.65	23.30	19.80	21.55	3.53	3.20	3.37	2.12	2.05	2.09	9.90	9.50	9.70
REYQ360XA	30	20.00	18.80	19.40	23.00	19.40	21.20	3.56	3.20	3.38	2.25	2.10	2.18	10.90	10.60	10.75
REYQ384XA	32	19.00	17.60	18.30	21.90	17.00	19.45	3.21	3.20	3.21	2.22	2.06	2.14	9.70	9.90	9.80
REYQ408XA	34	17.20	17.70	17.45	21.80	18.30	20.05	3.21	3.20	3.21	2.09	2.05	2.07	9.80	9.70	9.75
REYQ432XA	36	16.20	17.30	16.75	20.20	18.10	19.15	3.21	3.20	3.21	2.08	2.06	2.07	9.80	9.70	9.75
REYQ456XA	38	16.20	16.70	16.45	18.80	17.90	18.35	3.21	3.20	3.21	2.07	2.05	2.06	9.30	9.50	9.40

Certified efficiency data in accordance with ANSI/AHRI Standard 1230 2014, "Performance Rating of Variable Refrigerant Flow Multi-Split Air Conditioning and Heat Pump Equipment" for the VRF series. The VRF/IV X series has been designed and optimized to meet or exceed the latest minimum efficiency requirements in 10 C.F.R. Part 431 as determined by the U.S. Department of Energy (DOE) and baseline efficiencies as defined by ASHRAE 90.1 2016. Systems under 65MBH are currently certified to AHRI 210/240. IEER ratings are as defined in ASHRAE 90.1 2016.

**DETAILED OPERATION RANGES FOR VRF/IV X REYQ\_X HEAT RECOVERY OUTDOOR UNITS**

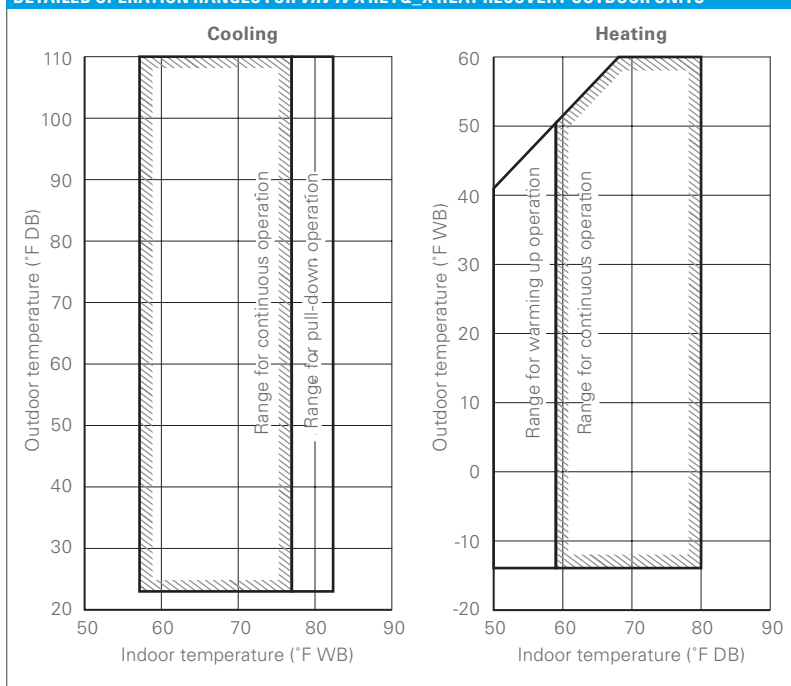

**TECHNICAL COOLING FEATURE FOR VRF/IV X REYQ\_X HEAT RECOVERY OUTDOOR UNITS**

**Technical Cooling -** Cooling operation extended from 23°F ambient air temperature down to -4°.

The Technical Cooling feature is engaged by field settings on the outdoor unit and on branch selector boxes. It requires addition of snow hoods to the unit and allows operation down to -4°F DB ambient temperature in cooling mode.

See the Engineering Data book for complete application rules and contact your local Daikin representative for wind cover specification requirements.

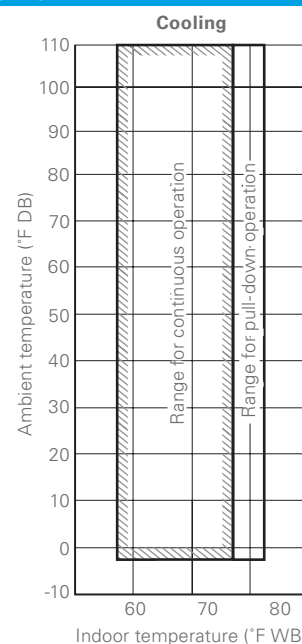

# VRV IV X

## Air-Cooled Heat Recovery (cont.)



### TECHNICAL DATA FOR VRV IV X-TATJA/TAYDA HEAT RECOVERY OUTDOOR UNITS

		6 Ton	8 Ton	10 Ton	12 Ton	14 Ton	16 Ton	18 Ton	20 Ton	
Model	208-230V/3Ph/60Hz	REYQ72XBTJA	REYQ96XBTJA	REYQ120XBTJA	REYQ144XBTJA	REYQ168XBTJA	REYQ192XBTJA	REYQ216XBTJA	REYQ240XBTJA	
	460V/3Ph/60Hz	REYQ72XBYDA	REYQ96XBYDA	REYQ120XBYDA	REYQ144XBYDA	REYQ168XBYDA	REYQ192XBYDA	REYQ216XBYDB	REYQ240XBYDA	
	Combination						2 x REYQ96XA	1 x REYQ96XA 1 x REYQ120XA	2 x REYQ120XA	
Performance	Rated Cooling Capacity	BTU/h	69,000	92,000	114,000	138,000	156,000	184,000	206,000	228,000
	Rated Heating Capacity	BTU/h	77,000	103,000	129,000	154,000	174,000	206,000	232,000	256,000
	Standard Operation Range Cooling	°F (°C) DB	23 to 122							
	Standard Operation Range Heating	°F (°C) WB	-13 to 60							
	Sound Pressure	dB(A)	65	65	65	66	66	68	68	68
	Airflow	CFM	7283	7989	7989	9480	9480	7989 + 7989	7989 + 7989	7989 + 7989
	Fan ESP, Standard/Max	in. W.G.	0.12 / 0.32							
Compressor	Compressors, all inverter	Qty	1				2			
	Revolutions per minute	RPM	3738	5142	6888	5214	6330	5214 + 5214	5994 + 5994	6702 + 6702
	Capacity Control Range	%	15-100	13-100	11-100	14-100	12-100	6-100	6-100	5-100
Refrigerant Piping, Layout	Maximum Vertical Pipe Length Above Unit	ft.	164 (295 With Field Setting)							
	Maximum Vertical Pipe Length Below Unit	ft.	130 (195 With Field Setting)							
	Maximum Vertical Pipe Length Between IDU	ft.	100							
	Maximum Actual Pipe Length	ft.	541							
	Maximum Equivalent Pipe Length	ft.	620							
	Maximum Total Pipe Length	ft.	3,280							
Refrigerant Piping, Connections	Liquid Pipe, Main Line	in.	3/8	3/8	1/2	1/2	5/8	5/8	5/8	5/8
	Suction Gas Pipe, Main Line	in.	3/4	7/8	1-1/8	1-1/8	1-1/8	1-1/8	1-1/8	1-3/8
	Discharge Gas Pipe, Main Line	in.	5/8	3/4	3/4	7/8	7/8	1-1/8	1-1/8	1-1/8
Connection Ratio	Standard Connectable Indoor Unit Ratio	%	70 - 200 <sup>1</sup>		50 - 200 <sup>1</sup>					
	Maximum Number of Indoor Units	Qty	12	16	20	25	29	33	37	41
Electrical	Maximum Overcurrent Protection, MOP (208-230v/460v)	A	45 / 25	45 / 25	50 / 25	70 / 40	70 / 40	45 + 45 / 25 + 25 /	45 + 50 / 25 + 25 /	50 + 50 / 25 + 25 /
	Minimum Circuit Amps, MCA (208-230v/460v)	A	38.1 / 18.9	38.1 / 21.1	43.0 / 21.1	58.3 / 27.9	61.9 / 31.1	38.1 + 38.1 / 21.1 + 21.1 /	38.1 + 43.0 / 21.1 + 21.1 /	43.0 + 43.0 / 21.1 + 21.1 /
	Compressor Rated Load Amps, (208-230v/460v)	A	20.8 / 9.4	23.3 / 10.5	28.2 / 12.8	42.6 / 19.3	49.0 / 22.2	24.7 + 24.7 / 11.2 + 11.2 /	28.5 + 28.5 / 12.9 + 12.9 /	29.0 + 29.0 / 13.5 + 13.5 /
Unit	Factory Refrigerant Charge	lbs.	25.8				25.8 + 25.8			
	Weight	lbs.	727	727	727	793	793	727 + 727	727 + 727	727 + 727
	Dimensions (H x W x D)	in.	66-11/16 x 48-7/8 x 30-3/16				66-11/16 x 48-7/8 x 30-3/16 + 66-11/16 x 48-7/8 x 30-3/16			

<sup>1</sup>Varies based on indoor model selected

### OPERATION RANGE FOR ALL VRV IV X HEAT RECOVERY OUTDOOR UNITS

Cooling°F DB	-4* – 122
Heating°F WB	-13 – 60

\*Application rules apply

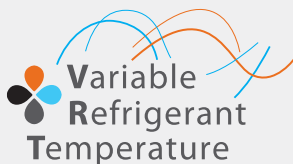

	22 Ton	24 Ton	26 Ton	28 Ton	30 Ton	32 Ton	34 Ton	36 Ton	38 Ton
	REYQ264XBTJA	REYQ288XBTJA	REYQ312XBTJA	REYQ336XBTJA	REYQ360XBTJA	REYQ384XBTJA	REYQ408XBTJA	REYQ432XBTJA	REYQ456XBTJA
	REYQ264XBYDA	REYQ288XBYDA	REYQ312XBYDB	REYQ336XBYDA	REYQ360XBYDA	REYQ384XBYDA	REYQ408XBYDA	REYQ432XBYDA	REYQ456XBYDA
	1 x REYQ120XB 1 x REYQ144XB	2 x REYQ144XB	1 x REYQ144XB 1 x REYQ168XB	2 x REYQ168XB	3 x REYQ120XB	2 x REYQ120XB 1 x REYQ144XB	1 x REYQ120XB 2 x REYQ144XB	2 x REYQ168XB	2 x REYQ144XB 1 x REYQ168XB
	252,000	274,000	296,000	320,000	342,000	364,000	388,000	410,000	430,000
	282,000	294,000	320,000	338,000	376,000	386,000	394,000	405,000	414,000
	23 to 122								
	-13 to 60								
	69	69	69	69	70	71	71	71	71
	7989 + 9480	9480 + 9480	9480 + 9480	9480 + 9480	7989 + 7989 + 7989	7989 + 7989 + 9480	7989 + 9480 + 9480	9480 + 9480 + 9480	9480 + 9480 + 9480
	0.12 / 0.32								
	2				3				
	6504 + 5214	4794 + 4794	5286 + 5286	5664 + 5664	6606 + 6606 + 6606	6426 + 6426 + 5070	6162 + 4470 + 4470	4350 + 4350 + 4350	4470 + 4470 + 4470
	5-100	7-100	7-100	6-100	4-100	3-100	3-100	5-100	4-100
	164 (295 With Field Setting)								
	130 (195 With Field Setting)								
	100								
	541								
	620								
	3,280								
	3/4	3/4	3/4	3/4	3/4	3/4	3/4	3/4	3/4
	1-3/8	1-3/8	1-3/8	1-3/8	1-5/8	1-5/8	1-5/8	1-5/8	1-5/8
	1-1/8	1-1/8	1-1/8	1-1/8	1-3/8	1-3/8	1-3/8	1-3/8	1-3/8
	50 - 200 <sup>1</sup>								
	45	49	54	58	64				
	50 + 70 / 25 + 40	70 + 70 / 40 + 40	70 + 70 / 40 + 40	70 + 70 / 40 + 40	50 + 50 + 50 / 25 + 25 + 25	50 + 50 + 70 / 25 + 25 + 40	50 + 70 + 70 / 25 + 40 + 40	70 + 70 + 70 / 40 + 40 + 40	70 + 70 + 70 / 40 + 40 + 40
	43.0+58.3/ 21.1+27.9	58.3+58.3/ 27.9+27.9	58.3+61.9/ 27.9+31.1	61.9+61.9/ 31.1+31.1	43.0+43.0+43.0/ 21.1+21.1+21.1	43.0+43.0+58.3/ 21.1+21.1+27.9	43.0+58.3+58.3/ 21.1+27.9+27.9	58.3+58.3+58.3/ 27.9+27.9+27.9	58.3+58.3+61.9/ 27.9+27.9+31.1 /
	32.9+42.1/ 14.9+19.0	43.5+43.5/ 19.7+19.7	46.5+46.5/ 21.0+21.0	50.1+50.1/ 22.7+22.7	32.7+32.7+32.7/ 14.8+14.8+14.8	33.8+33.8+43.7/ 15.3+15.3+19.8	35.7+45.1+45.1/ 16.2+20.4+20.4	45.1+45.1+45.1/ 20.4+20.4+20.4	47.0+47.0+47.0/ 21.3+21.3+21.3
	25.8 + 25.8				25.8 + 25.8 + 25.8				
	727 + 793	793 + 793	793 + 793	793 + 793	727 + 727 + 727	727 + 727 + 793	727 + 793 + 793	793 + 793 + 793	793 + 793 + 793
	66-11/16 x 48-7/8 x 30-3/16 + 66-11/16 x 48-7/8 x 30-3/16				66-11/16 x 48-7/8 x 30-3/16 + 66-11/16 x 48-7/8 x 30-3/16 + 66-11/16 x 48-7/8 x 30-3/16				

For additional technical information please refer to specific Engineering Data Books.

# High-Efficiency All-Electric Heat Pump Hot and Chilled Water Solutions



Daikin's LT hydrobox (HXY48TAVJU) offers an all-electric means of refrigerant to water heat exchange providing an efficient method for hot and cold-water generation for many hydronic solutions including high-efficiency space heating and cooling. The LT hydrobox combines with Daikin's VRV systems for expanded indoor unit flexibility with hydronic integration. Delivering water from 50°F – 113°F without the need for a backup electric heater, for use in underfloor heating and cooling, air handling units, and low-temperature radiators, making it an ideal choice in both new construction and renovation applications.

The stylish and compact wall hung unit with front access and minimal clearance requirements make it ideal for installation in tight spaces and ease of maintenance.

## Features and Benefits

- » Direct control over the leaving water temperature for a wide leaving water temperature range down to 50°F in cooling and up to 113°F in heating.
- » Eliminates the need for gas connection or oil tanks to generate hot or cold water
- » Space-saving contemporary wall hung design
- » Seamless integration with VRV IV X systems<sup>1</sup>
- » Save time on system design as all water components are fully integrated with direct control over leaving water temperature. Factory installed hydronic accessories include:

## Applications:

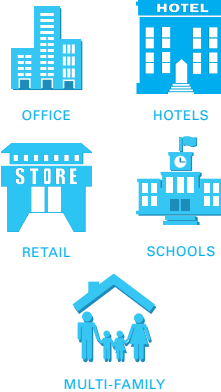

- Flow switch
- Safety relief valve
- Expansion tank
- Pump
- Strainer
- Auto air vent valve
- Inlet/outlet temp sensors

<sup>1</sup> Refer to the engineering manuals for detailed design conditions.



\* Complete warranty details available from your local distributor, manufacturer's representative, [www.daikincomfort.com](http://www.daikincomfort.com).





SPECIFICATIONS			
Model		HXY48TAVJU	
Power Supply		V/ph/Hz	208/230VAC 60 Hz, 1-Phase
Nominal Capacity	Cooling* <sup>1</sup>	Btu/h (kW)	42,650 (12.5)
	Heating* <sup>2</sup>	Btu/h (kW)	48,000 (14.0)
Pump	Type		DC Motor
	Nr of Speeds		Inverter Controlled
	Cooling Nominal ESP	ft hd (kPa)	24.4 (73)
	Heating Nominal ESP	ft hd (kPa)	21.8 (65)
Dimensions (H x W x D)		in. (mm)	35 1/16 x 18 7/8 x 13 1/2 (890 x 480 x 344)
Weight (Dry)		lbs (kg)	97 (44)
Casing		(Color / Material)	White / Precoated Sheet Metal
Sound	Power Level	dBA	60
	Pressure Level	dBA	31
Water Flow Rate Range		gpm (l/min)	3.4 - 11.9 (15 - 45)
Pump Control Method			Water Inlet/Outlet Delta T Control
Delta T Range		°F (°C)	5.4 - 14.4 (3 - 8)
Outlet Temp. Range	Cooling	°F (°C)	50 - 68 (10 - 20)
	Heating	°F (°C)	77 - 113 (25 - 45)
Ambient Temperature Range	Cooling	°F (°C)	50 - 109 (10 - 43)
	Heating	°F (°C)	-4 - 75 (-20 - 24)
Pipe Connections	Liquid	in. (mm)	3/8 (9.5) (Flare)
	Gas	in. (mm)	5/8 (15.9) (Flare)
	Water Side Connection* <sup>3</sup>	in. (mm)	1 1/4 (31.8)
Refrigerant Control			Electronic Expansion Valve
Maximum Overcurrent Protection		A	15
Minimum Circuit Ampacity		A	2.5

NOTE:

\*<sup>1</sup> Nominal Cooling Conditions

\*<sup>2</sup> Nominal Heating Conditions

\*<sup>3</sup> Adaptor Shipped Loose with IDU (BSPP to NPT)

Ambient: 95°F DB, LWT: 64.4°F, Delta T: 9°F, Flow Rate: 9.5 gpm

Ambient: 44.6°F DB / 42.8°F WB, LWT: 95°F, Delta T: 9°F, Flow Rate: 10.6 gpm

### Installation Example

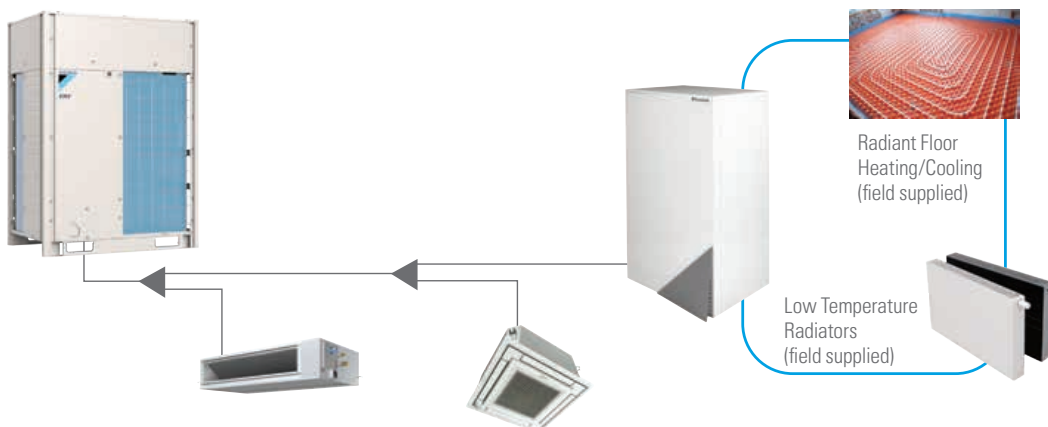

## **VRV IV X, VRV EMERION**

Indoor Units 80-97% AFUE  
Communicating Gas Furnace

### Features

- » **Compatible with VRV IV X and VRV EMERION outdoor units.** Available from 60,000 Btu up to 120,000 Btu
- » **Durable heat exchanger** – Unique tubular stainless-steel construction formed using wrinkle-bend technology results in an extremely durable heat exchanger. Paired with a stainless-steel secondary heat exchanger, this combination provides for reliability, durability and efficiency.
- » **Modulating gas valve** – Operates between 35% - 100% capacity, providing precise efficiency and the ultimate in comfort.
- » **Continuous air circulation** – Provides filtration and keeps air moving throughout your home to help maintain comfort.
- » **Self-diagnostic control board** – continuously monitors the system for consistent, reliable operation.
- » **Quiet, variable-speed induced draft blower** – provides precise control and enhanced energy-efficient performance as compared to single-speed blowers.







# Daikin VRV AURORA

Heat Recovery | 208-230V & 460V



Daikin VRV AURORA series heat recovery systems introduce a new benchmark for variable refrigerant flow system technology by integrating advanced technologies to provide comfort, control, energy efficiency and reliability. The Daikin VRV AURORA series heat recovery systems set a new industry standard for heating and cooling solutions by delivering high heat capacities at low ambient applications.

## Features and Benefits

- » Variable refrigerant flow system Industry's first air-cooled system that delivers heating down to -22°F (-30°C) as standard
- » Daikin's inverter based vapor injection compressor is designed to deliver heating capacity of up to 100% of nominal at 0°F (-18°C), up to 85% of nominal at -13°F (-25°C) and up to 60% of nominal at -22°F (-30°C)
- » Optimized efficiencies delivered by dedicated all-inverter compressors and inverter fan motors
- » Refrigerant-cooled efficient and stable inverter board operation, independent of ambient conditions
- » Hot gas base pan circuit allows installation without an additional drain pan heater
- » Designed to provide continuous heating during defrost and oil return\*\*
- » Engineered with Daikin vapor injection compressor for optimized part load efficiencies
- » Added peace of mind with Auto Changeover ability to back up (auxiliary) heat

## VRV

### Applications:



- » Long pipe lengths up to 1640 ft total and ability to connect up to 41\*\*\* indoor units with up to 100 ft vertical separation between indoor units provides design and installation flexibility
- » Corrosion resistant, 1000 hours salt spray tested Daikin PE blue fin heat exchanger
- » Ships factory standard with coil guards
- » Outstanding 10-Year Parts Warranty\* as standard.

\* Complete commercial warranty details available from your local distributor or manufacturer's representative or at [www.daikincomfort.com](http://www.daikincomfort.com)  
\*\* Multi modules only for continuous heating during defrost  
\*\*\*Varies by model





# Variable Refrigerant Temperature

## VRV AURORA HEAT RECOVERY CERTIFIED DATA - HEAT RECOVERY, 208-230V/60HZ/3PH AND 460V/60HZ/3PH

Product #	Capacity (Tons)	IEER Non-Ducted	IEER Ducted	IEER Mixed	SCHE Non-Ducted	SCHE Ducted	SCHE Mixed	COP @ 47°F Non-Ducted	COP @ 47°F Ducted	COP @ 47°F Mixed	COP @ 17°F Non-Ducted	COP @ 17°F Ducted	COP @ 17°F Mixed	EER Non-Ducted	EER Ducted	EER Mixed
RELQ72T	6	24.00	20.80	22.40	26.10	22.60	24.30	4.30	3.68	3.99	2.50	2.30	2.40	15.80	13.70	14.70
RELQ96T	8	24.80	19.10	21.90	25.70	19.70	22.70	4.23	3.42	3.83	2.50	2.25	2.37	15.30	12.50	13.90
RELQ120T	10	23.40	19.60	21.50	26.70	21.10	24.00	3.98	3.51	3.74	2.25	2.25	2.25	13.70	12.40	13.00
RELQ144T	12	22.50	18.60	20.50	25.50	23.80	24.60	3.81	3.55	3.68	2.20	2.20	2.20	12.90	12.60	12.70
RELQ192T	16	22.10	19.00	20.50	25.50	21.20	23.30	3.85	3.57	3.71	2.20	2.15	2.17	12.50	12.70	12.60
RELQ240T	20	21.10	18.60	19.80	24.90	20.80	22.80	3.68	3.49	3.59	2.20	2.13	2.16	12.30	11.70	12.00

Certified efficiency data in accordance with ANSI/AHRI Standard 1230 2014, "Performance Rating of Variable Refrigerant Flow Multi-Split Air Conditioning and Heat Pump Equipment" for the VRV series. The VRV AURORA series has been designed and optimized to meet or exceed the latest minimum efficiency requirements in 10 C.F.R. Part 431 as determined by the U.S. Department of Energy (DOE) and baseline efficiencies as defined by ASHRAE 90.1 2016. Systems under 65MBH are currently certified to AHRI 210/240. IEER ratings are as defined in ASHRAE 90.1 2016.

### DETAILED OPERATION RANGES FOR VRV/RELO\_T HEAT RECOVERY OUTDOOR UNITS

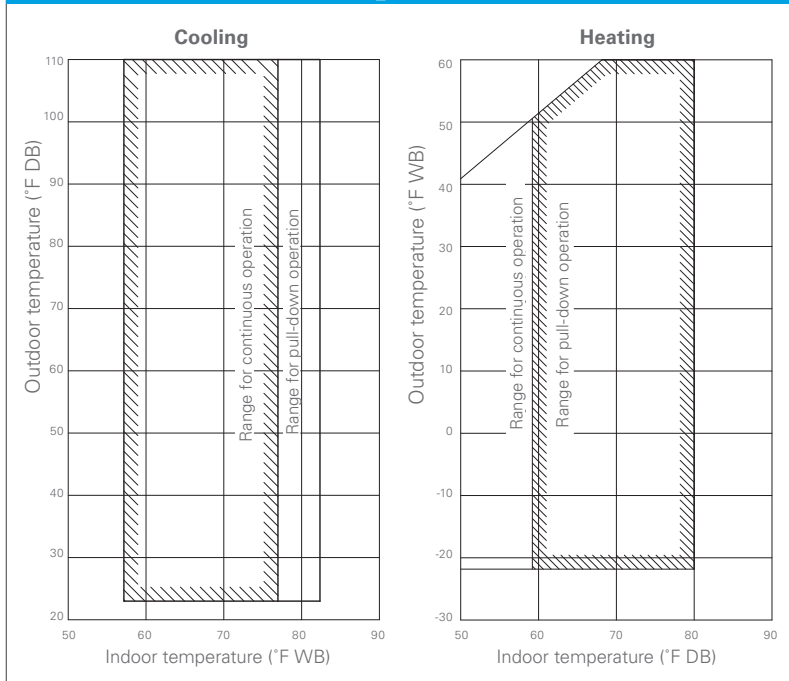

### TECHNICAL COOLING FEATURE FOR VRV/RELO\_T HEAT RECOVERY OUTDOOR UNITS

**Technical Cooling -**  
Cooling operation extended from 23°F ambient air temperature down to -4°.  
The Technical Cooling feature is engaged by field settings on the outdoor unit and on branch selector boxes. It requires addition of wind covers to the unit and allows operation down to -4°F DB ambient temperature in cooling mode.  
See the Engineering Data book for complete application rules and contact your local Daikin representative for wind cover specification requirements.

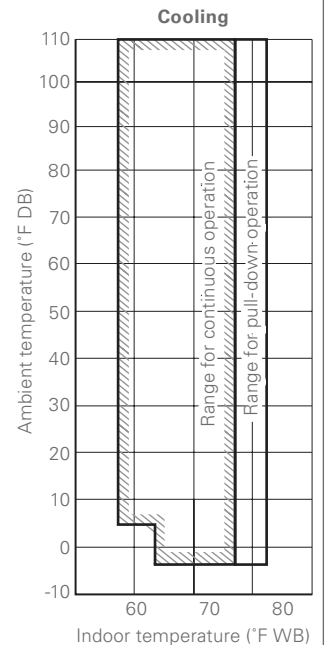

# Daikin VRV AURORA

Heat Recovery | 208-230V & 460V (cont.)

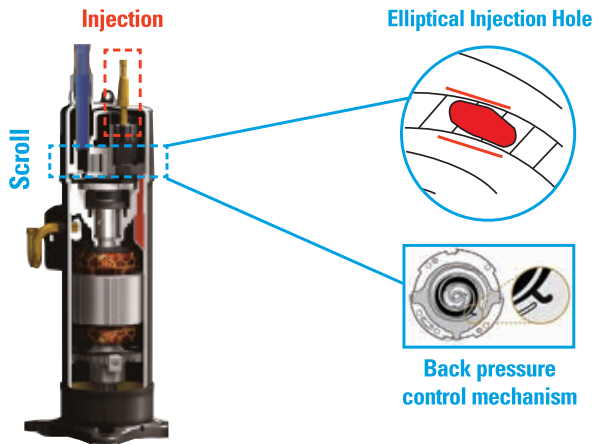

- » Compressor technology with new spiral design and injection valves for precise refrigerant control
- » Strong and efficient motors for optimized compressor performance and part load efficiencies
- » Patented back pressure control mechanism to minimize scroll pressure losses

TECHNICAL DATA FOR VRV AURORA RELQ_TATJA/TAYDA HEAT RECOVERY OUTDOOR UNITS			6 Ton	8 Ton	10 Ton
Model	208-230V/3Ph/60Hz		RELQ72TBTJA	RELQ96TBTJA	RELQ120TBTJA
	460V/3Ph/60Hz		RELQ72TAYDA	RELQ96TAYDA	RELQ120TAYDA
	Combination				
Performance	Rated Cooling Capacity	BTU/h	69,000	92,000	114,000
	Rated Heating Capacity	BTU/h	77,000	103,000	129,000
	Operation Range Cooling	°F (°C) DB	23 <sup>1</sup> to 122		
	Operation Range Heating	°F (°C) WB	-22 to 60		
	Sound Pressure	dB(A)	60	61	64
	Airflow (Cooling)	CFM	6956	7989	8806
	Airflow (Heating)	CFM	7283	7283	7283
	Fan ESP, Standard/Max	in. Wg	0.12 / 0.32		
Compressor	Compressors, all inverter	Qty	1		
	Revolutions per minute	RPM	3738	3342	4350
	Capacity Control Range	%	11-100	10-100	9-100
Refrigerant Piping, Layout	Maximum Vertical Pipe Length Above Unit	ft.	164 (295 With Field Setting)		
	Maximum Vertical Pipe Length Below Unit	ft.	131 (195 With Field Setting)		
	Maximum Vertical Pipe Length Between IDU	ft.	100		
	Maximum Actual Pipe Length	ft.	541		
	Maximum Equivalent Pipe Length	ft.	620		
	Maximum Total Pipe Length	ft.	1,640		
Refrigerant Piping, Connections	Liquid Pipe (Main Line)	in.	3/8	3/8	1/2
	Suction Gas Pipe (Main Line)	in.	3/4	7/8	1-1/8
	Discharge Gas Pipe (Main Line)	in.	5/8	3/4	3/4
Connection Ratio	Standard Connectable Indoor Unit Ratio	%	70 - 200 <sup>2</sup>		
	Maximum Number of Indoor Units	Qty	12	16	20
Electrical	Maximum Overcurrent Protection, MOP (RELQ_TATJA / RELQ_TAYDA)	A	70 / 35	80 / 45	90 / 50
	Minimum Circuit Amps, MCA (RELQ_TATJA / RELQ_TAYDA)	A	60.8 / 28.1	76.5 / 39.8	83.4 / 43.4
	Compressor Rated Load Amps, RLA (RELQ_TATJA / RELQ_TAYDA)	A	20.7 / 9.4	36.8 / 16.6	39.3 / 17.8
Unit	Factory Refrigerant Charge	lbs.	25.8		
	Weight	lbs.	727	793	793
	Dimensions (H x W x D)	in.	66-11/16 X 48-7/8 X 30-3/16		

<sup>1</sup> Cooling operation can be extended down to -4°F with application rules and conditions

<sup>2</sup> Varies based on indoor model selected



Variable  
Refrigerant  
Temperature

		12 Ton	16 Ton	20 Ton	
Model	208-230V/3Ph/60Hz	RELQ144TATJA	RELQ192TATJA	RELQ240TATJA	
	460V/3Ph/60Hz	RELQ144TAYDA	RELQ192TAYDA	RELQ240TAYDA	
	Combination	2 x RELQ72T	2 x RELQ96T	2 x RELQ120T	
Performance	Rated Cooling Capacity	BTU/h	138,000	184,000	228,000
	Rated Heating Capacity	BTU/h	154,000	206,000	256,000
	Operation Range Cooling	°F (°C) DB	23 <sup>1</sup> to 122		
	Operation Range Heating	°F (°C) WB	-22 to 60		
	Sound Pressure	dB(A)	63	64	67
	Airflow (Cooling)	CFM	7283 + 7283	7989 + 7989	8806 + 8806
	Airflow (Heating)	CFM	6956 + 6956	7283 + 7283	7283 + 7283
	Fan ESP, Standard/Max	in. Wg	0.12 / 0.32		
Compressor	Compressors, all inverter	Qty	2		
	Revolutions per minute	RPM	3786 + 3786	3294 + 3294	4230 + 4230
	Capacity Control Range	%	6-100	5-100	4-100
Refrigerant Piping, Layout	Maximum Vertical Pipe Length Above Unit	ft.	164 (295 With Field Setting)		
	Maximum Vertical Pipe Length Below Unit	ft.	131 (195 With Field Setting)		
	Maximum Vertical Pipe Length Between IDU	ft.	100		
	Maximum Actual Pipe Length	ft.	541		
	Maximum Equivalent Pipe Length	ft.	620		
Refrigerant Piping, Connections	Maximum Total Pipe Length	ft.	1,640		
	Liquid Pipe (Main Line)	in.	1/2	5/8	5/8
	Suction Gas Pipe (Main Line)	in.	1-1/8	1-1/8	1-3/8
	Discharge Gas Pipe (Main Line)	in.	7/8	1-1/8	1-1/8
Connection Ratio	Standard Connectable Indoor Unit Ratio	%	70 - 200 <sup>2</sup>		
	Maximum Number of Indoor Units	Qty	25	33	41
Electrical	Maximum Overcurrent Protection, MOP (RELQ_TATJA / RELQ_TAYDA)	A	70 + 70 / 35 + 35	80 + 80 / 45 + 45	90 + 90 / 50 + 50
	Minimum Circuit Amps, MCA (RELQ_TATJA / RELQ_TAYDA)	A	60.8 + 60.8 / 28.1 + 28.1	76.5 + 76.5 / 39.8 + 39.8	83.4 + 83.4 / 43.4 + 43.4
	Compressor Rated Load Amps, RLA (RELQ_TATJA / RELQ_TAYDA)	A	21.6 + 21.6 / 9.8 + 9.8	38.1 + 38.1 / 17.3 + 17.3	40.4 + 40.4 / 18.3 + 18.3
Unit	Factory Refrigerant Charge	lbs.	25.8 + 25.8		
	Weight	lbs.	2 x 727	2 x 793	2 x 793
	Dimensions (H x W x D)	in.	66-11/16 X 48-7/8 X 30-3/16 + 66-11/16 X 48-7/8 X 30-3/16		

# Daikin VRV AURORA

Heat Pump | 208-230V & 460V



Daikin VRV AURORA series systems introduce a new benchmark for variable refrigerant flow system technology by integrating advanced technologies to provide comfort, control, energy efficiency and reliability. The Daikin VRV AURORA series systems set a new industry standard for heating and cooling solutions by delivering high heat capacities at low ambient applications.

## Features and Benefits

- » Variable refrigerant flow system Industry's first air-cooled system that delivers heating capacities down to -22°F (-30°C) as standard
- » Daikin's inverter based vapor injection compressor is designed to deliver heating capacity of up to 100% of nominal at 0°F (-18°C), up to 85% of nominal at -13°F (-25°C) and up to 60% of nominal at -22°F (-30°C)
- » Year round comfort and energy savings with Variable Refrigerant Temperature technology (VRT)
- » Refrigerant-cooled efficient and stable inverter board operation, independent of ambient conditions
- » Hot gas base pan circuit allows installation without an additional drain pan heater
- » Added peace of mind with Auto Changeover ability to back up (auxiliary) heat

## VRV

### Applications:



- » Long pipe lengths up to 1640 ft. total and ability to connect up to 41\*\* indoor units with up to 100 ft. vertical separation between indoor units provides design and installation flexibility
- » Corrosion resistant, 1000 hours salt spray tested Daikin PE blue fin heat exchanger
- » Ships factory standard with coil guards
- » Outstanding 10-Year Parts Warranty\* as standard.

\* Complete commercial warranty details available from your local distributor or manufacturer's representative or at [www.daikincomfort.com](http://www.daikincomfort.com)  
\*\* Varies by model





# Variable Refrigerant Temperature

## VRV AURORA HEAT PUMP CERTIFIED DATA - HEAT PUMP, 208-230V/60HZ/3PH, 460V/60HZ/3PH

Product #	Capacity (Tons)	IEER Non-Ducted	IEER Ducted	IEER Mixed	COP @ 47°F Non-Ducted	COP @ 47°F Ducted	COP @ 47°F Mixed	COP @ 17°F Non-Ducted	COP @ 17°F Ducted	COP @ 17°F Mixed	EER Non-Ducted	EER Ducted	EER Mixed
RXLQ72T	6	24.00	20.40	22.20	4.37	3.73	4.05	2.52	2.31	2.42	15.10	13.00	14.05
RXLQ96T	8	24.70	18.90	21.80	4.29	3.49	3.89	2.51	2.26	2.39	14.90	12.30	13.60
RXLQ120T	10	23.30	19.40	21.35	4.05	3.56	3.81	2.27	2.26	2.27	13.50	12.20	12.85
RXLQ144T	12	22.40	18.20	20.30	3.86	3.56	3.71	2.21	2.21	2.21	12.70	12.40	12.55
RXLQ192T	16	22.00	18.80	20.40	3.90	3.61	3.76	2.22	2.16	2.19	12.30	12.50	12.40
RXLQ240T	20	21.00	18.60	19.80	3.77	3.53	3.65	2.22	2.13	2.18	12.10	11.50	11.80

Certified efficiency data in accordance with ANSI/AHRI Standard 1230 2014, "Performance Rating of Variable Refrigerant Flow Multi-Split Air Conditioning and Heat Pump Equipment" for the VRV series. The VRV AURORA series has been designed and optimized to meet or exceed the latest minimum efficiency requirements in 10 C.F.R. Part 431 as determined by the U.S. Department of Energy (DOE) and baseline efficiencies as defined by ASHRAE 90.1 2016. Systems under 65MBH are currently certified to AHRI 210/240. IEER ratings are as defined in ASHRAE 90.1 2016.

## DETAILED OPERATION RANGES FOR VRV/RXLQ\_T HEAT PUMP OUTDOOR UNITS

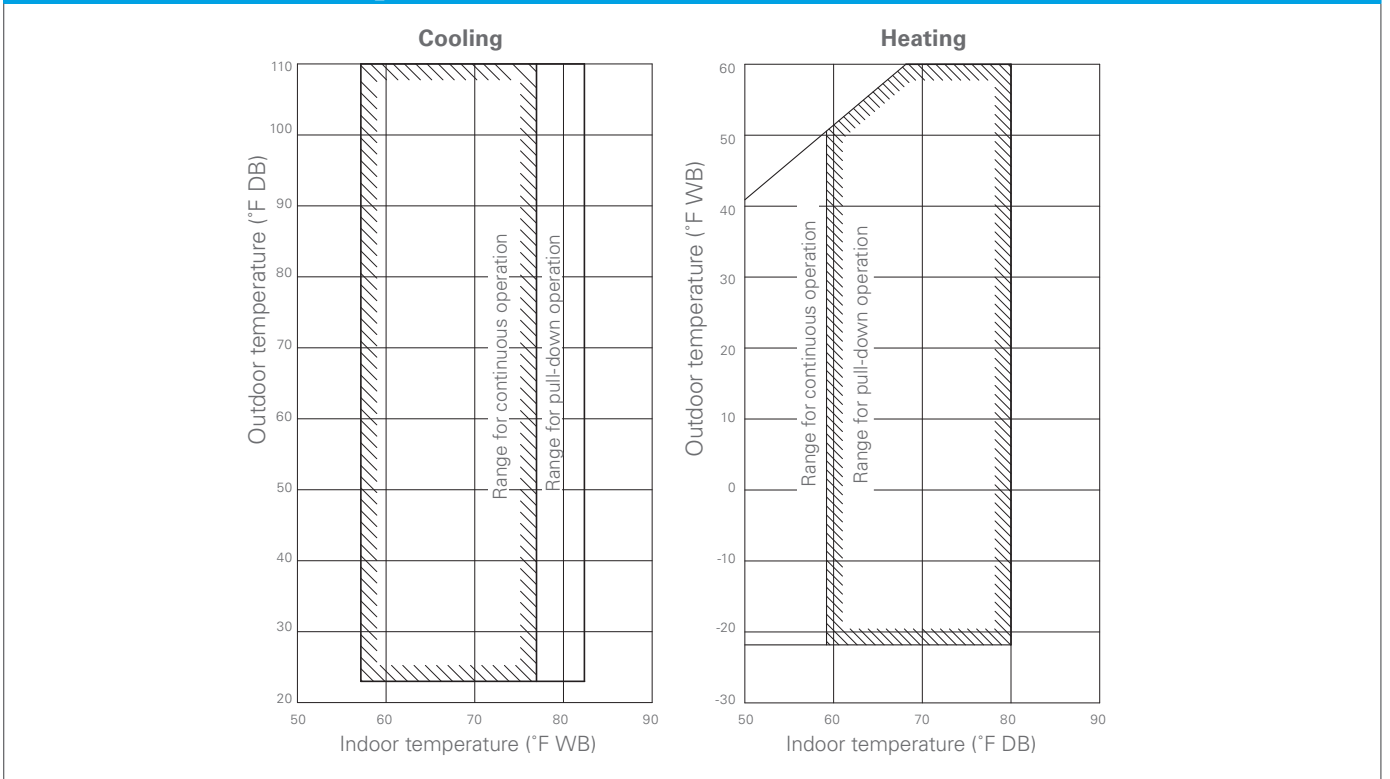

# Daikin VRV AURORA

Heat Pump | 208-230V & 460V (cont.)

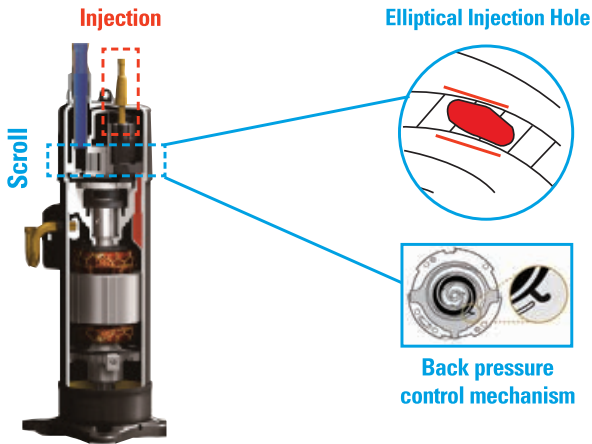

- » Compressor technology with new spiral design and injection valves for precise refrigerant control
- » Strong and efficient motors for optimized compressor performance and part load efficiencies
- » Patented back pressure control mechanism to minimize scroll pressure losses

## TECHNICAL DATA FOR VRV AURORA RXLQ\_T

		208-230V/3Ph/60Hz		6 Ton	8 Ton	10 Ton
		460V/3Ph/60Hz		RXLQ72TBTJA	RXLQ96TBTJA	RXLQ120TBTJA
		Combination		RXLQ72TBYDA	RXLQ96TBYDA	RXLQ120TBYDA
Performance	Rated Cooling Capacity		BTU/h	69,000	92,000	114,000
	Rated Heating Capacity		BTU/h	77,000	103,000	129,000
	Operation Range Cooling		°F (°C) DB	23 to 122		
	Operation Range Heating		°F (°C) WB	-22 to 60		
	Sound Pressure		dB(A)	60	61	64
	Airflow		CFM	7283	7989	8806
	Fan ESP, Standard/Max		in. Wg	0.12 / 0.32		
Compressor	Compressors, all inverter		Qty	1		
	Revolutions per minute		RPM	3738	3294	4350
	Capacity Control Range		%	11-100	13-100	12-100
Refrigerant Piping, Layout	Maximum Vertical Pipe Length Above Unit		ft.	164 (295 With Field Setting)		
	Maximum Vertical Pipe Length Below Unit		ft.	131 (195 With Field Setting)		
	Maximum Vertical Pipe Length Between IDU		ft.	100		
	Maximum Actual Pipe Length		ft.	541		
	Maximum Equivalent Pipe Length		ft.	620		
Refrigerant Piping, Connections	Maximum Total Pipe Length		ft.	1,640		
	Liquid Pipe (Main Line)		in.	3/8	3/8	1/2
Connection Ratio	Suction Gas Pipe (Main Line)		in.	3/4	7/8	1-1/8
	Standard Connectable Indoor Unit Ratio		%	70 - 200 <sup>1</sup>		
Electrical	Maximum Number of Indoor Units		Qty	12	16	20
	Maximum Overcurrent Protection, MOP (RXLQ_TATJA / RXLQ_TAYDA)		A	70 / 35	80 / 45	90 / 50
	Minimum Circuit Amps, MCA (RXLQ_TATJA / RXLQ_TAYDA)		A	60.8 / 28.1	76.5 / 39.8	83.4 / 43.4
Unit	Compressor Rated Load Amps, RLA (RXLQ_TATJA / RXLQ_TAYDA)		A	23.9 / 10.4	42.2 / 18.3	41.4 / 18.0
	Factory Refrigerant Charge		lbs.	25.8		
	Weight		lbs.	727	793	793
	Dimensions (H x W x D)		in.	66-11/16 X 48-7/8 X 30-3/16		

<sup>1</sup>Varies based on indoor model selected





# Variable Refrigerant Temperature

			12 Ton	16 Ton	20 Ton
Model			RXLQ144TATJA	RXLQ192TATJA	RXLQ240TATJA
		208-230V/3Ph/60Hz	RXLQ144TAYDA	RXLQ192TAYDA	RXLQ240TAYDA
		460V/3Ph/60Hz Combination	2 x RXLQ72T	2 x RXLQ96T	2 x RXLQ120T
Performance	Rated Cooling Capacity	BTU/h	138,000	184,000	228,000
	Rated Heating Capacity	BTU/h	154,000	206,000	256,000
	Operation Range Cooling	°F (°C) DB	23 to 122		
	Operation Range Heating	°F (°C) WB	-22 to 60		
	Sound Pressure	dB(A)	63	64	67
	Airflow (Cooling)	CFM	7283 + 7283	7989 + 7989	8806 + 8806
	Fan ESP, Standard/Max	in. Wg	0.12 / 0.32		
Compressor	Compressors, all inverter	Qty	2		
	Revolutions per minute	RPM	3804 + 3804	3342 + 3342	4230 + 4230
	Capacity Control Range	%	6-100	6-100	6-100
Refrigerant Piping, Layout	Maximum Vertical Pipe Length Above Unit	ft.	164 (295 With Field Setting)		
	Maximum Vertical Pipe Length Below Unit	ft.	131 (195 With Field Setting)		
	Maximum Vertical Pipe Length Between IDU	ft.	100		
	Maximum Actual Pipe Length	ft.	541		
	Maximum Equivalent Pipe Length	ft.	620		
Refrigerant Piping, Connections	Maximum Total Pipe Length	ft.	1,640		
	Liquid Pipe (Main Line)	in.	1/2	5/8	5/8
Connection Ratio	Suction Gas Pipe (Main Line)	in.	1-1/8	1-1/8	1-3/8
	Standard Connectable Indoor Unit Ratio	%	70 - 200 <sup>1</sup>		
Electrical	Maximum Number of Indoor Units	Qty	25	33	41
	Maximum Overcurrent Protection, MOP (RXLQ_TATJA / RXLQ_TAYDA)	A	70 + 70 / 35 + 35	80 + 80 / 45 + 45	90 + 90 / 50 + 50
	Minimum Circuit Amps, MCA (RXLQ_TATJA / RXLQ_TAYDA)	A	60.8 + 60.8 / 28.1 + 28.1	76.5 + 76.5 / 39.8 + 39.8	83.4 + 83.4 / 43.4 + 43.4
Unit	Compressor Rated Load Amps, RLA (RXLQ_TATJA / RXLQ_TAYDA)	A	23.9 + 23.9 / 10.4 + 10.4	40.8 + 40.8 / 17.7 + 17.7	41.7 + 41.7 / 18.2 + 18.2
	Factory Refrigerant Charge	lbs.	25.8 + 25.8		
	Weight	lbs.	2 x 727	2 x 793	2 x 793
	Dimensions (H x W x D)	in.	66-11/16 X 48-7/8 X 30-3/16 + 66-11/16 X 48-7/8 X 30-3/16		

# VRV T-Series Water-Cooled

Heat Pump | Heat Recovery  
208-230V | 460V

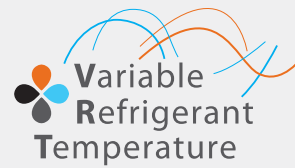

VRV T-Series Water-Cooled systems are equivalent to 4-pipe chilled water systems, but also offer a viable alternative to Water Source Heat Pump solutions. Each connected indoor unit can provide heating and cooling independently to suit zone requirements making these systems suitable for both open plan, or cellar applications with different operation requirements.

## Features and Benefits

- » Flexible System design with increased diversity up to 150%<sup>1</sup> compared to previous VRV water-cooled generation
- » Triple-stack capable to deliver up to 36 tons in 11.5 ft ceiling height
- » Flexible and easy installation with field selectable top or front refrigerant connections
- » Design flexibility with long piping lengths up to 980 ft. total (540 ft. max. linear liquid piping length) and up to 100 ft. vertical separation between indoor units
- » Engineered with heat rejection cancellation technology<sup>2</sup> to minimize mechanical room conditioning requirements
- » Year round comfort and energy efficiency by combining VRV and VRT technologies
- » Wide water temperature operation range - Can be applied to both geothermal and boiler/tower applications as standard with condenser water inlet temperature as low as 14°F in heating and 23°F in cooling is possible.
- » 2-9V variable water flow control logic<sup>2</sup> as standard to increase waterside system operational efficiencies
- » Refrigerant cooled inverter technology to deliver consistent and reliable PCB operations
- » Easy commissioning with ability to program settings off site using new configurator tool
- » 3-digit 7-segment digital display on the unit for improved and faster configuration, commissioning, and troubleshooting
- » Engineered for easy service with drop-down switch box to access key components

<sup>1</sup> Model specific, check product specification for details

<sup>2</sup> Refer to installation manual for field settings and other requirements to activate this feature

VRV Water-Cooled System series design is based on a modular design concept. It is composed of unified condensing units that require simply connecting a two-pipe refrigerant network for heat pump applications or a three-pipe refrigerant network for heat recovery applications. Water-cooled condensers are available in 6\*, 8, 10 and 12 tons.



### Water side

Connects to cooling tower and/or boiler combination or set up as geothermal.

### Refrigerant side

Connects to Daikin's line-up of VRV indoor units

The condensers are smaller and can be stacked, reducing the installation space and increasing the customers' usable square footage.

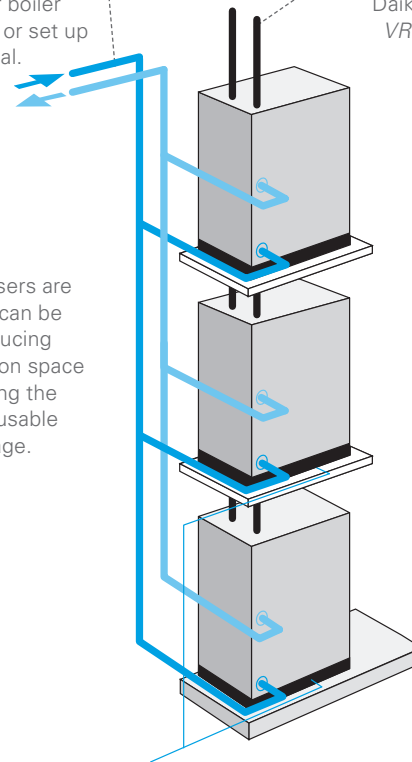

This is a simple system that allows manifolding together up to three condensers to form one system of up to 36 tons. The condensers are designed for internal mounting only.

\* 6-ton model (RWEYQ72PC) is PC series. T and PC series models cannot be combined to form multi-module systems.

**VRV T-SERIES WATER-COOLED CERTIFIED DATA, 208-230V/60HZ/3PH AND 460V/60HZ/3PH**

Function	System Name	Tonnage	IEER Non-Ducted	IEER Ducted	IEER Mixed	SCHE Non-Ducted (Heat Recovery only)	SCHE Ducted (Heat Recovery only)	SCHE Mixed (Heat Recovery only)	EER Non-Ducted	EER Ducted	EER Mixed	COP @ 68°F Non-Ducted	COP @ 68°F Ducted	COP @ 68°F Mixed
Heat Pump	RWEQ72T	6 Tons	24.1	22.3	23.2	N/A	N/A	N/A	14.0	14.0	14.0	4.89	4.78	4.84
	RWEQ96T	8 Tons	30.8	25.4	28.1	N/A	N/A	N/A	19.6	15.4	17.5	6.27	5.8	6.035
	RWEQ120T	10 Tons	29.4	23.5	26.45	N/A	N/A	N/A	16	13.6	14.8	6.1	5.55	5.83
	RWEQ144T	12 Tons	24.3	19.8	22.05	N/A	N/A	N/A	15.4	12.6	14.0	6.01	5.33	5.67
	RWEQ192T	16 Tons	26.8	24.7	25.75	N/A	N/A	N/A	16.5	14.6	15.55	5.82	5.82	5.82
	RWEQ216T	18 Tons	26.3	23.8	25.05	N/A	N/A	N/A	15.0	13.8	14.4	5.68	5.62	5.65
	RWEQ240T	20 Tons	25.7	22.7	24.2	N/A	N/A	N/A	14.0	12.8	13.4	5.52	5.38	5.45
	RWEQ264T	22 Tons	23.5	2.00	21.75	N/A	N/A	N/A	13.5	12.1	12.8	5.34	4.96	5.15
	RWEQ288T	24 Tons	20.9	18.8	19.85	N/A	N/A	N/A	12.6	11.3	11.95	5.3	4.81	5.06
	RWEQ312T	26 Tons	21.9	21.8	21.85	N/A	N/A	N/A	13.7	12.7	13.2	5.5	4.86	5.18
	RWEQ336T	28 Tons	21.5	21.4	21.45	N/A	N/A	N/A	13.5	12.3	12.9	5.42	4.73	5.08
	RWEQ360T	30 Tons	21.2	20.2	20.7	N/A	N/A	N/A	12.4	11.7	12.05	5.3	4.7	5.0
RWEQ384T	32 Tons	19.5	17.9	18.7	N/A	N/A	N/A	12	11	11.5	4.53	4.12	4.33	
RWEQ408T	34 Tons	18.2	17.2	17.7	N/A	N/A	N/A	11.1	10.7	10.9	4.35	4.03	4.19	
RWEQ432T	36 Tons	17.0	16.6	16.8	N/A	N/A	N/A	10.5	10.3	10.4	4.19	3.92	4.06	
Heat Recovery	RWEQ72T	6 Tons	24.1	22.3	23.2	17.8	19.2	18.5	14.0	14.0	14.0	4.89	4.78	4.84
	RWEQ96T	8 Tons	30.8	25.4	28.1	25.7	21.3	23.5	19.6	15.4	17.5	6.27	5.8	6.035
	RWEQ120T	10 Tons	29.4	23.5	26.45	26.3	22.5	24.4	16	13.6	14.8	6.1	5.55	5.83
	RWEQ144T	12 Tons	24.3	19.8	22.05	26.5	22.7	24.6	15.4	12.6	14	6.01	5.33	5.67
	RWEQ192T	16 Tons	26.8	24.7	25.75	26.0	22.9	24.45	16.5	14.6	15.55	5.82	5.82	5.82
	RWEQ216T	18 Tons	26.3	23.8	25.05	25.5	22.1	23.8	15.0	13.8	14.4	5.68	5.62	5.65
	RWEQ240T	20 Tons	25.7	22.7	24.2	25.4	21.9	23.65	14.0	12.8	13.4	5.52	5.38	5.45
	RWEQ264T	22 Tons	23.5	2.00	21.75	25.2	19.2	22.2	13.5	12.1	12.8	5.34	4.96	5.15
	RWEQ288T	24 Tons	20.9	18.8	19.85	23.5	20.0	21.75	12.6	11.3	11.95	5.3	4.81	5.06
	RWEQ312T	26 Tons	21.9	21.8	21.85	24.5	20.7	22.6	13.7	12.7	13.2	5.5	4.86	5.18
	RWEQ336T	28 Tons	21.5	21.4	21.45	23.5	20.0	21.75	13.5	12.3	12.9	5.42	4.73	5.08
	RWEQ360T	30 Tons	21.2	20.2	20.7	23.2	19.1	21.15	12.4	11.7	12.05	5.3	4.7	5.0
RWEQ384T	32 Tons	19.5	17.9	18.7	22.0	19.1	20.55	12.0	11.0	11.5	4.53	4.12	4.33	
RWEQ408T	34 Tons	18.2	17.2	17.7	21.2	18.5	19.85	11.1	10.7	10.9	4.35	4.03	4.19	
RWEQ432T	36 Tons	17.0	16.6	16.8	20.5	17.7	19.1	10.5	10.3	10.4	4.19	3.92	4.055	

Certified efficiency data in accordance with ANSI/AHRI Standard 1230 2014, "Performance Rating of Variable Refrigerant Flow Multi-Split Air Conditioning and Heat Pump Equipment" for the VRV T-Series Water-Cooled. The VRV T-Series Water-Cooled has been designed and optimized to meet or exceed the latest minimum efficiency requirements in 10 C.F.R. Part 431 as determined by the U.S. Department of Energy (DOE) and baseline efficiencies as defined by ASHRAE 90.1 2016. Systems under 65MBH are currently certified to AHRI 210/240. IEER ratings are as defined in ASHRAE 90.1 2016.

**DETAILED STANDARD OPERATION RANGES FOR VRV T-SERIES WATER-COOLED CONDENSING UNITS**

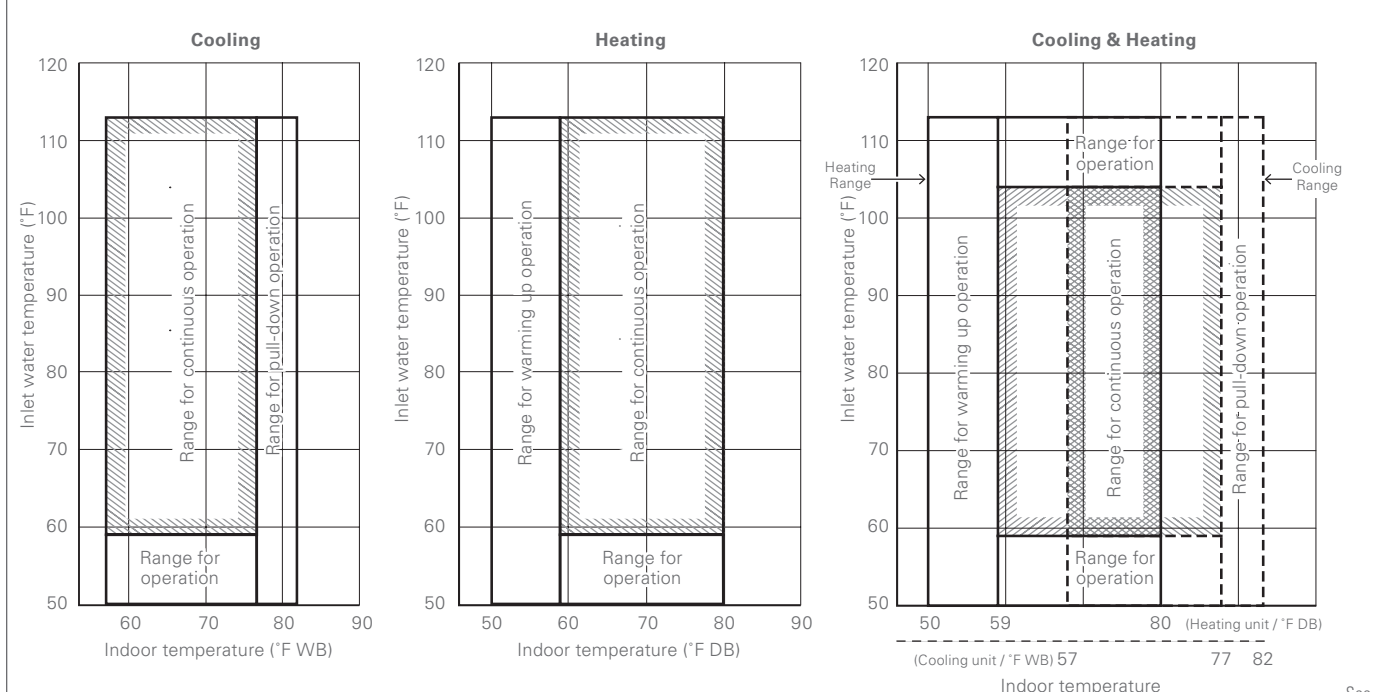

the Engineering Data book for complete application rules and extended geothermal operation ranges

See

# VRV T-Series Water-Cooled

Heat Pump or Heat Recovery  
208-230V

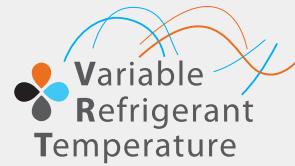

A modular, energy-efficient and reliable alternative to centralized equipment

## Features and Benefits

- » Flexible System design with increased diversity up to 150%<sup>1</sup> compared to previous VRV water-cooled generation
- » Small condensers can be triple stacked for reduced installation space and increased usable square footage
- » Larger (than previous models) single-system capacity and modular concept ensures wider application range for accommodating floor-by-floor loads of commercial buildings
- » Year round comfort and energy efficiency by combining VRV and VRT technologies
- » Can be applied to both geothermal and boiler/tower applications as standard with condenser water inlet temperature as low as 14°F in heating and 23°F in cooling is possible
- » 2-9V variable water flow control logic<sup>2</sup> as standard to increase waterside system operational efficiencies
- » Refrigerant cooled inverter technology to deliver consistent and reliable PCB operations
- » Engineered for easy service with drop-down switch box to access key components

<sup>1</sup> Model specific, check product specification for details

<sup>2</sup> Refer to installation manual for field settings and other requirements to activate this feature

VRV T-SERIES UNIFIED HEAT PUMP AND HEAT RECOVERY 208-230V & 460V																		
		6 Ton		8 Ton		10 Ton		12 Ton		14 Ton		16 Ton		18 Ton		20 Ton		
Model	208-230V/3Ph/60Hz	RWEQ72TBTJA	RWEQ96TBTJA	RWEQ120TBTJA	RWEQ144TBTJA	RWEQ168TBTJA	RWEQ192TBTJA	RWEQ216TBTJA	RWEQ240TBTJA									
	460V/3Ph/60Hz	RWEQ72TBYDA	RWEQ96TBYDA	RWEQ120TBYDA	RWEQ144TBYDA	RWEQ168TBYDA	RWEQ192TBYDA	RWEQ216TBYDA	RWEQ240TBYDA									
Combination										RWEQ72T RWEQ96T	2 x RWEQ96T	RWEQ96T RWEQ120T	2 x RWEQ120T					
Performance	Rated Cooling Capacity <sup>1</sup>	BTU/h	69,000	92,000	114,000	138,000	156,000	184,000	206,000	228,000								
	Rated Heating Capacity <sup>2</sup>	BTU/h	69,000	92,000	114,000	138,000	156,000	184,000	206,000	228,000								
	Sound Pressure Level @ 3 ft.	dB(A)	50	54	55	60.5		57	57.5	58								
Refrigerant Piping	System Configuration: Heat Pump: HP, Heat Recovery: HR		HP	HR	HP	HR	HP	HR	HP	HR	HP	HR	HP	HR	HP	HR		
	Liquid Pipe (Main Line)	in.	3/8	3/8	3/8	3/8	1/2	1/2	1/2	1/2	5/8 - 5/8	5/8	5/8	5/8	5/8	5/8	5/8	
	Suction Gas Pipe (Main Line)	in.	3/4	5/8	7/8	3/4	1-1/8	3/4	1-1/8	7/8	1-1/8 - 1-1/8	1-1/8	1-1/8	1-1/8	1-1/8	1-3/8	1-1/8	
	Discharge Gas Pipe (Main Line)	in.	N/A	3/4	N/A	7/8	N/A	1-1/8	N/A	1-1/8	7/8 - 7/8	N/A	1-1/8	N/A	1-1/8	N/A	1-3/8	
Connection Ratio	Standard Connectable Indoor Unit Ratio <sup>3</sup>	%	50 - 130		50 - 150													
	Maximum Number of Indoor Units	Qty.	12	16	20	25	1-1/4	33	37	41								
Water Side (Standard)	BPHE Inlet Pipe (Female Thread)	in.	1-1/4		1-1/4		1-1/4		1-1/4		1-1/4		2 x 1-1/4		2 x 1-1/4		2 x 1-1/4	
	BPHE Outlet Pipe (Female Thread)	in.	1-1/4		1-1/4		1-1/4		1-1/4		3/8		2 x 1-1/4		2 x 1-1/4		2 x 1-1/4	
	Drain Pipe (Female Thread)	in.	1/2		3/8		3/8		3/8		60.5		2 x 3/8		2 x 3/8		2 x 3/8	
	Maximum System Water Pressure (BPHE)	psi	285		464													
	Standard Inlet Water Temperature Range Cooling	°F	50 - 113															
	Standard Inlet Water Temperature Range Heating	°F	50 - 113															
Water Side (Geothermal)	Recommended Inlet Water Flow Rate per Module (minimum)	gpm	15.9 - 39.6 (13.2)															
	Inlet Water Temperature Range Cooling <sup>4</sup>	°F	27 - 113		23 - 113													
	Inlet Water Temperature Range Heating <sup>4</sup>	°F	14 - 95															
	Water Flow Rate <sup>5</sup>	gpm	21.2 - 39.6															
Unit	Weight (230V/460V)	lbs.	434.3 / 440.9	434.3 / 440.9	438.7 / 445.3	438.7 / 445.3					2 X 440.9 / 2 X 440.9	438.7 + 434.3 / 445.3 + 440.9	2 x 438.7 / 2 x 445.3					
	Dimensions (H x W x D)	in.	38-9/16 x 30-1/8 x 22-1/16		38-9/16 x 30-1/8 x 22-1/16						38-9/16 x (30-1/8 x 2) x 22-1/16							
Electrical (208-230V)	Maximum Overcurrent Protection (MOP)	V	40	40	50	60					40 + 40	40 + 50	50 + 50					
	Minimum Circuit Amps (MCA)	A	37.9	38.3	45.2	52.6					38.3 + 38.3	38.3 + 45.2	45.2 + 45.2					
Electrical (460V)	Maximum Overcurrent Protection (MOP)	A	20	20	25	25					20 + 20	25 + 25	25 + 25					
	Minimum Circuit Amps (MCA)	A	17.2	17.3	20.4	23.8					17.3 + 17.3	17.3 + 20.4	20.4 + 20.4					
Compressor	Compressor Type		Inverter															
	Compressor Capacity Control	%	23 - 100	16 - 100	14 - 100	11 - 100					8 - 100	8 - 100	7 - 100					

<sup>1</sup> Indoor temp.: 80°FDB, 67°FWB/inlet water temp.: 85°F / Equivalent piping length: 25 ft., level difference: 0 ft.

<sup>2</sup> Indoor temp.: 70°FDB, 60°FWB/inlet water temp.: 70°F / Equivalent piping length: 25 ft., level difference: 0 ft.

<sup>3</sup> Varies based on indoor and condensing unit model selected; refer to Engineering Manual for details.



RWEQ\_TATJA/TAYDA

22 Ton		24 Ton		26 Ton		28 Ton		30 Ton		32 Ton		34 Ton		36 Ton	
RWEQ264TBTJA		RWEQ288TBTJA*		RWEQ312TBTJA*		RWEQ336TBTJA*		RWEQ360TBTJA*		RWEQ384TBTJA*		RWEQ408TBTJA*		RWEQ432TBTJA*	
RWEQ264TBYDA		RWEQ288TBYDA*		RWEQ312TBYDA*		RWEQ336TBYDA*		RWEQ360TBYDA*		RWEQ384TBYDA*		RWEQ408TBYDA*		RWEQ432TBYDA*	
RWEQ120T RWEQ144T		2 x RWEQ144TB		2 x RWEQ96TB RWEQ120TB		RWEQ96TB 2 x RWEQ120TB		3 x RWEQ120TB		2 x RWEQ120TB RWEQ144TB		RWEQ120TB 2 x RWEQ144TB		3 x RWEQ144TB	
252,000		274,000		296,000		320,000		342,000		366,000		388,000		402,000	
252,000		274,000		298,000		320,000		342,000		366,000		388,000		402,000	
61.5		63.5		59		59.5		60		62		64		65	
HP	HR	HP	HR	HP	HR	HP	HR	HP	HR	HP	HR	HP	HR	HP	HR
3/4	3/4	3/4	3/4	3/4	3/4	3/4	3/4	3/4	3/4	3/4	3/4	3/4	3/4	3/4	3/4
1-3/8	1-1/8	1-3/8	1-1/8	1-3/8	1-1/8	1-3/8	1-1/8	1-5/8	1-3/8	1-5/8	1-3/8	1-5/8	1-3/8	1-5/8	1-3/8
N/A	1-3/8	N/A	1-3/8	N/A	1-3/8	N/A	1-3/8	N/A	1-5/8	N/A	1-5/8	N/A	1-5/8	N/A	1-5/8
50 - 150															
45		49		54		58		62		64		64		64	
2 x 1-1/4		2 x 1-1/4		3 x 1-1/4		3 x 1-1/4		3 x 1-1/4		3 x 1-1/4		3 x 1-1/4		3 x 1-1/4	
2 x 1-1/4		2 x 1-1/4		3 x 1-1/4		3 x 1-1/4		3 x 1-1/4		3 x 1-1/4		3 x 1-1/4		3 x 1-1/4	
2 x 3/8		2 x 3/8		3 x 3/8		3 x 3/8		3 x 3/8		3 x 3/8		3 x 3/8		3 x 3/8	
464															
50 - 113															
50 - 113															
15.9 - 39.6 (13.2)															
23 - 113															
14 - 95															
21.2 - 39.6															
2 x 438.7 / 2 x 445.3		2 x 438.7 / 2 x 445.3		2 x 434.3 + 438.7 2 x 440.9 + 445.3		434.3 + 2 x 438.7 440.9 + 2 x 445.3		434.3 + 2 x 438.7 / 440.9 + 2 x 445.3		3 x 438.7 / 3 x 445.3		3 x 438.7 / 3 x 445.3		3 x 438.7 / 3 x 445.3	
38-9/16 x 30-1/8 x 22-1/16															
50 + 60		60 + 60		40 + 40 + 50		40 + 50 + 50		50 + 50 + 50		50 + 50 + 50		50 + 60 + 60		60 + 60 + 60	
45.2 + 52.6		52.6 + 52.6		38.3 + 38.3 + 45.2		38.3 + 45.2 + 45.2		45.2 + 45.2 + 45.2		45.2 + 45.2 + 52.6		45.2 + 52.6 + 52.6		52.6 + 52.6 + 52.6	
25 + 25		25 + 25		20 + 20 + 25		20 + 25 + 25		25 + 25 + 25		25 + 25 + 25		25 + 25 + 25		25 + 25 + 25	
20.4 + 23.8		23.8 + 23.8		17.3 + 17.3 + 20.4		17.3 + 20.4 + 20.4		20.4 + 20.4 + 20.4		20.4 + 20.4 + 23.8		20.4 + 23.8 + 23.8		23.8 + 23.8 + 23.8	
Inverter															
6 - 100		5 - 100		5 - 100		5 - 100		5 - 100		5 - 100		4 - 100		4 - 100	

<sup>4</sup> Application rules apply below 50°F. Please contact your local Daikin office for design assistance and approval.

<sup>5</sup> Please note that a water strainer (standard accessory for the T-Series, field supplied for the PC-series) is required for each condensing unit.

<sup>6</sup> PC series model. Some features and benefits may not be available for this model.

# VRV T-Series Water-Cooled Heat Pump or Heat Recovery | 460V

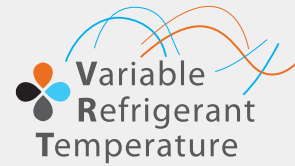

A modular, energy-efficient and reliable alternative to centralized equipment

## Features and Benefits

- » Flexible System design with increased diversity up to 150%<sup>1</sup> compared to previous VRV water-cooled generation
- » Small condensers can be triple stacked for reduced installation space and increased usable square footage
- » Larger (than previous models) single-system capacity and modular concept ensures wider application range for accommodating floor-by-floor loads of commercial buildings
- » Year round comfort and energy efficiency by combining VRV and VRT technologies
- » Can be applied to both geothermal and boiler/tower applications as standard with condenser water inlet temperature as low as 14°F in heating and 23°F in cooling is possible
- » 2-9V variable water flow control logic<sup>2</sup> as standard to increase waterside system operational efficiencies
- » Refrigerant cooled inverter technology to deliver consistent and reliable PCB operations
- » Engineered for easy service with drop-down switch box to access key components

<sup>1</sup> Model specific, check product specification for details

<sup>2</sup> Refer to installation manual for field settings and other requirements to activate this feature

VRV T-SERIES UNIFIED HEAT PUMP AND HEAT RECOVERY 208-230V & 460V																		
		6 Ton		8 Ton		10 Ton		12 Ton		14 Ton		16 Ton		18 Ton		20 Ton		
Model	208-230V/3Ph/60Hz	RWEQ72TBTJA	RWEQ96TBTJA	RWEQ120TBTJA	RWEQ144TBTJA	RWEQ168TBTJA	RWEQ192TBTJA	RWEQ216TBTJA	RWEQ240TBTJA									
	460V/3Ph/60Hz	RWEQ72TBYDA	RWEQ96TBYDA	RWEQ120TBYDA	RWEQ144TBYDA	RWEQ168TBYDA	RWEQ192TBYDA	RWEQ216TBYDA	RWEQ240TBYDA									
Combination										RWEQ72T RWEQ96T	2 x RWEQ96T	RWEQ96T RWEQ120T	2 x RWEQ120T					
Performance	Rated Cooling Capacity <sup>1</sup>	BTU/h	69,000	92,000	114,000	138,000	156,000	184,000	206,000	228,000								
	Rated Heating Capacity <sup>2</sup>	BTU/h	69,000	92,000	114,000	138,000	156,000	184,000	206,000	228,000								
	Sound Pressure Level @ 3 ft.	dB(A)	50	54	55	60.5		57	57.5	58								
Refrigerant Piping	System Configuration: Heat Pump: HP, Heat Recovery: HR		HP	HR	HP	HR	HP	HR	HP	HR	HP - HR	HP	HR	HP	HR	HP	HR	
	Liquid Pipe (Main Line)	in.	3/8	3/8	3/8	3/8	1/2	1/2	1/2	1/2	5/8 - 5/8	5/8	5/8	5/8	5/8	5/8	5/8	
	Suction Gas Pipe (Main Line)	in.	3/4	5/8	7/8	3/4	1-1/8	3/4	1-1/8	7/8	1-1/8 - 1-1/8	1-1/8	1-1/8	1-1/8	1-1/8	1-3/8	1-1/8	
	Discharge Gas Pipe (Main Line)	in.	N/A	3/4	N/A	7/8	N/A	1-1/8	N/A	1-1/8	7/8 - 7/8	N/A	1-1/8	N/A	1-1/8	N/A	1-3/8	
Connection Ratio	Standard Connectable Indoor Unit Ratio <sup>3</sup>	%	50 - 130		50 - 150													
	Maximum Number of Indoor Units	Qty.	12		16		20		25		1-1/4		33		37		41	
Water Side (Standard)	BPHE Inlet Pipe (Female Thread)	in.	1-1/4		1-1/4		1-1/4		1-1/4		1-1/4		2 x 1-1/4		2 x 1-1/4		2 x 1-1/4	
	BPHE Outlet Pipe (Female Thread)	in.	1-1/4		1-1/4		1-1/4		1-1/4		3/8		2 x 1-1/4		2 x 1-1/4		2 x 1-1/4	
	Drain Pipe (Female Thread)	in.	1/2		3/8		3/8		3/8		60.5		2 x 3/8		2 x 3/8		2 x 3/8	
	Maximum System Water Pressure (BPHE)	psi	285		464													
	Standard Inlet Water Temperature Range Cooling	°F	50 - 113															
	Standard Inlet Water Temperature Range Heating	°F	50 - 113															
Water Side (Geothermal)	Recommended Inlet Water Flow Rate per Module (minimum)	gpm	15.9 - 39.6 (13.2)															
	Inlet Water Temperature Range Cooling <sup>4</sup>	°F	27 - 113		23 - 113													
	Inlet Water Temperature Range Heating <sup>4</sup>	°F	14 - 95															
Unit	Water Flow Rate <sup>5</sup>	gpm	21.2 - 39.6															
	Weight (230V/460V)	lbs.	434.3 / 440.9	434.3 / 440.9	438.7 / 445.3	438.7 / 445.3							2 X 440.9 / 2 X 440.9	438.7 + 434.3 / 445.3 + 440.9	2 X 438.7 / 2 X 445.3			
Electrical (208-230V)	Dimensions (H x W x D)	in.	38-9/16 x 30-1/8 x 22-1/16		38-9/16 x 30-1/8 x 22-1/16						38-9/16 x (30-1/8 x 2) x 22-1/16							
	Maximum Overcurrent Protection (MOP)	V	40		40		50		60				40 + 40		40 + 50		50 + 50	
Electrical (460V)	Minimum Circuit Amps (MCA)	A	37.9		38.3		45.2		52.6				38.3 + 38.3		38.3 + 45.2		45.2 + 45.2	
	Maximum Overcurrent Protection (MOP)	A	20		20		25		25				20 + 20		25 + 25		25 + 25	
Compressor	Minimum Circuit Amps (MCA)	A	17.2		17.3		20.4		23.8				17.3 + 17.3		17.3 + 20.4		20.4 + 20.4	
	Compressor Type		Inverter															
Compressor	Compressor Capacity Control	%	23 - 100		16 - 100		14 - 100		11 - 100				8 - 100		8 - 100		7 - 100	

<sup>1</sup> Indoor temp.: 80°FDB, 67°FWB/inlet water temp.: 85°F / Equivalent piping length: 25 ft., level difference: 0 ft.

<sup>2</sup> Indoor temp.: 70°FDB, 60°FWB/inlet water temp.: 70°F / Equivalent piping length: 25 ft., level difference: 0 ft.

<sup>3</sup> Varies based on indoor and condensing unit model selected; refer to Engineering Manual for details.

RWEQ\_TATJA/TAYDA



22 Ton		24 Ton		26 Ton		28 Ton		30 Ton		32 Ton		34 Ton		36 Ton	
RWEQ264TBTJA		RWEQ288TBTJA*		RWEQ312TBTJA*		RWEQ336TBTJA*		RWEQ360TBTJA*		RWEQ384TBTJA*		RWEQ408TBTJA*		RWEQ432TBTJA*	
RWEQ264TBYDA		RWEQ288TBYDA*		RWEQ312TBYDA*		RWEQ336TBYDA*		RWEQ360TBYDA*		RWEQ384TBYDA*		RWEQ408TBYDA*		RWEQ432TBYDA*	
RWEQ120T RWEQ144T		2 x RWEQ144TB		2 x RWEQ96TB RWEQ120TB		RWEQ96TB 2 x RWEQ120TB		3 x RWEQ120TB		2 x RWEQ120TB RWEQ144TB		RWEQ120TB 2 x RWEQ144TB		3 x RWEQ144TB	
252,000		274,000		296,000		320,000		342,000		366,000		388,000		402,000	
252,000		274,000		298,000		320,000		342,000		366,000		388,000		402,000	
61.5		63.5		59		59.5		60		62		64		65	
HP	HR	HP	HR	HP	HR	HP	HR	HP	HR	HP	HR	HP	HR	HP	HR
3/4	3/4	3/4	3/4	3/4	3/4	3/4	3/4	3/4	3/4	3/4	3/4	3/4	3/4	3/4	3/4
1-3/8	1-1/8	1-3/8	1-1/8	1-3/8	1-1/8	1-3/8	1-1/8	1-5/8	1-3/8	1-5/8	1-3/8	1-5/8	1-3/8	1-5/8	1-3/8
N/A	1-3/8	N/A	1-3/8	N/A	1-3/8	N/A	1-3/8	N/A	1-5/8	N/A	1-5/8	N/A	1-5/8	N/A	1-5/8
50 - 150															
45		49		54		58		62		64		64		64	
2 x 1-1/4		2 x 1-1/4		3 x 1-1/4		3 x 1-1/4		3 x 1-1/4		3 x 1-1/4		3 x 1-1/4		3 x 1-1/4	
2 x 1-1/4		2 x 1-1/4		3 x 1-1/4		3 x 1-1/4		3 x 1-1/4		3 x 1-1/4		3 x 1-1/4		3 x 1-1/4	
2 x 3/8		2 x 3/8		3 x 3/8		3 x 3/8		3 x 3/8		3 x 3/8		3 x 3/8		3 x 3/8	
464															
50 - 113															
50 - 113															
15.9 - 39.6 (13.2)															
23 - 113															
14 - 95															
21.2 - 39.6															
2 x 438.7 / 2 x 445.3		2 x 438.7 / 2 x 445.3		2 x 434.3 + 438.7 2 x 440.9 + 445.3		434.3 + 2 x 438.7 440.9 + 2 x 445.3		434.3 + 2 x 438.7 / 440.9 + 2 x 445.3		3 x 438.7 / 3 x 445.3		3 x 438.7 / 3 x 445.3		3 x 438.7 / 3 x 445.3	
38-9/16 x 30-1/8 x 22-1/16															
50 + 60		60 + 60		40 + 40 + 50		40 + 50 + 50		50 + 50 + 50		50 + 50 + 50		50 + 60 + 60		60 + 60 + 60	
45.2 + 52.6		52.6 + 52.6		38.3 + 38.3 + 45.2		38.3 + 45.2 + 45.2		45.2 + 45.2 + 45.2		45.2 + 45.2 + 52.6		45.2 + 52.6 + 52.6		52.6 + 52.6 + 52.6	
25 + 25		25 + 25		20 + 20 + 25		20 + 25 + 25		25 + 25 + 25		25 + 25 + 25		25 + 25 + 25		25 + 25 + 25	
20.4 + 23.8		23.8 + 23.8		17.3 + 17.3 + 20.4		17.3 + 20.4 + 20.4		20.4 + 20.4 + 20.4		20.4 + 20.4 + 23.8		20.4 + 23.8 + 23.8		23.8 + 23.8 + 23.8	
Inverter															
6 - 100		5 - 100		5 - 100		5 - 100		5 - 100		5 - 100		4 - 100		4 - 100	

<sup>4</sup> Application rules apply below 50°F. Please contact your local Daikin office for design assistance and approval.

<sup>5</sup> Please note that a water strainer (standard accessory for the T-Series, field supplied for the PC-series) is required for each condensing unit.

<sup>6</sup> PC series model. Some features and benefits may not be available for this model.

# VRV S-series (R-32)

## Heat Pump | 208-230V

### R32

#### Small Size, Robust Possibility.

The Daikin VRV-S elevates the renowned VRV air-cooled technology with its sleek, compact design tailored for small-scale installations without compromising performance. The Daikin VRV-S comes integrated with Variable Refrigerant Temperature (VRT) technology that supports optimal comfort throughout the year while maintaining overall energy efficiency.

Leveraging the engineering design opportunities of R-32, the new Daikin VRV-S provides an expansion of the product offering as well as several improvements compared to the previous Daikin VRV IV S-series. The new Daikin VRV-S improvements include the addition of a 2-ton size, single-fan chassis in all sizes, longer pipe lengths, efficiency, and capacity improvements, and more!

#### Light Commercial and Residential

A highly efficient solution, the Daikin VRV-S can provide cooling and heating for up to 9 zones. With many different indoor unit options, systems can be paired with a mix of ducted and duct-free indoor units for a customizable system. Designed for flexibility and versatility, the Daikin VRV-S system provides long piping lengths, which are accommodating and space-saving for almost any floor layout.

#### Low GWP R-32 Refrigerant:

Aligning with Daikin's goals of decarbonization, sustainability, and advancement towards clean energy, Daikin VRV-S models feature Low GWP R-32 refrigerant. Widely used and proven around the globe, easily available, efficient, and affordable, R-32 is an ideal choice to replace R-410A. Additionally, R-32 is a single component refrigerant offering simplicity and flexibility in charging and reclaiming (compared to blended refrigerants)



Capacity Range: 2 to 5 tons

#### Applications:



OFFICE



HOTELS



RESIDENTIAL



SCHOOLS

#### Features, Benefits, and Improvements:

- » Addition of a 2-ton model for a complete 2- to 5-ton offering
- » Long pipe lengths with vertical separation up to 164 ft. and total pipe length up to 984 ft.
- » Compact, space-saving single fan chassis design across all sizes
- » Dependable operation in extreme ambient conditions of up to 122°F<sup>1</sup>
- » Compact height of only 34-1/4" to support a range of applications
- » Efficient operation and year-round energy savings through Variable Refrigerant Temperature (VRT) technology
- » Improved efficiencies in heating and cooling operation compared to the previous R-410A lineup
- » Quiet operation with sound levels as low as 56 dB(A)
- » Ease of retrofit of existing R-410A installation with the ability to re-use larger diameter refrigerant pipes via field setting
- » Optional base pan heater to defrost base pan in cooler climate applications
- » Increased nominal capacity compared to previous R-410A lineup up to 60,000 Btu/hr for the 5T model

<sup>1</sup> Conditions/rules apply. Refer to the Installation and Engineering Manual for details.





DAIKIN VRV-S SERIES						
Model Name			RXTA24AAVJU	RXTA36AAVJU	RXTA48AAVJU	RXTA60AAVJU
Style	ODU Style	Fan Type	Single Fan			
Performance	Nominal Cooling Capacity	BTU/H	24,000	36,000	48,000	60,000
	Nominal Heating Capacity	BTU/H	27,000	40,000	52,000	60,000
	Operation Range Cooling	°F DB	23 to 122			
	Operation Range Heating	°F WB	-4 to 60			
	Power	V/P/Hz	208-230/1/60			
Refrigerant Piping	Sound Pressure Level @ 3ft	dB(A)	56	56	56	57
	Refrigerant		R-32			
	Refrigerant Quantity	lbs.	7.5	7.5	7.5	7.5
	Liquid Pipe (Main Line)	in.	3/8			
	Suction Gas Pipe (Main Line)	in.	5/8			
	Vertical Drop	ft.	164			
	Vertical Rise	ft.	130			
	Maximum vertical pipe length between IDU	ft.	49			
Connection Ratio	Actual Pipe Length (Equivalent Length)	ft.	394 (492)			
	Total Piping Length	ft.	984			
Unit	Connectable Indoor Unit Ratio	%	50-130			
	Number of Indoor Units	Qty	4	6	8	9
Fan	Outdoor Unit Size	(HxWxD)	34-1/4 x 43-5/16 x 18-1/8			
	Weight	lbs.	220			
Electrical	Airflow	CFM	3000			
	Fan Motor Output and Quantity	kW	0.20 x 1			
Compressor	Maximum Over Current Protection (MOP)	A	20	20	30	35
	Minimum Circuit Amps (MCA)	A	19.8	19.8	29.4	34.6
Compressor	Compressor Type	Type	Daikin Swing	Daikin Swing	Daikin Swing	Daikin Swing
	Capacity Control	%	14-100	14-100	14-100	14-100

Daikin VRV-S outdoor heat pumps are compatible only with the R-32 indoor units. R-410A-based indoor units are not compatible with the new Daikin VRV-S heat pump.

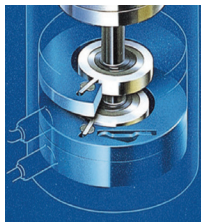

## The Daikin Swing Compressor

- » Daikin VRV-S SERIES built with the highly reliable Daikin swing compressor
- » Daikin's swing compressor technology integrates all the moving parts into one component
- » The integration minimizes abrasion between moving parts and refrigerant leakage through gaps from high to low pressure zones
- » Daikin's swing compressors deliver higher compressor efficiencies than a standard rotary compressor



## VRT mode control selection to match user preferences

Basic mode is selected to maintain optimal comfort. VRT is selected to save energy and prevent excessive cooling.

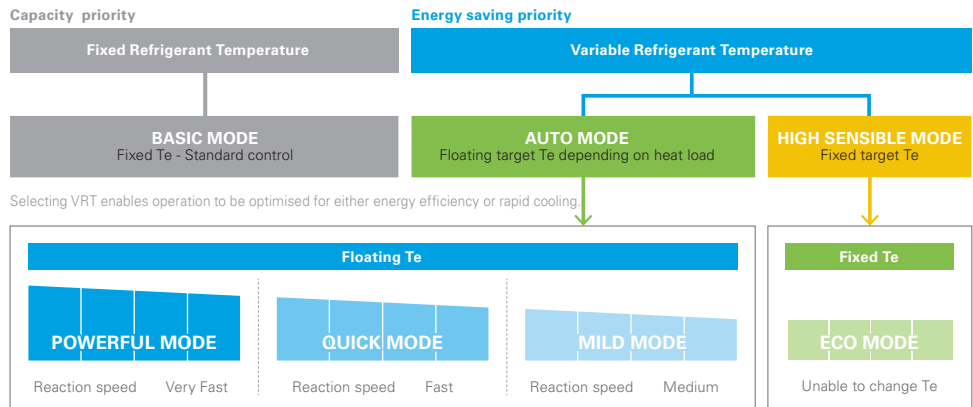
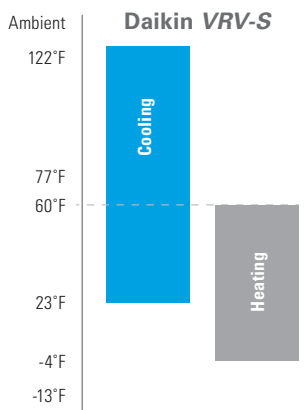

- » Can boost capacity above 100% if needed. The refrigerant temperature can go lower in cooling than the set minimum.
- » Gives priority to very fast reaction speed. The refrigerant temperature goes down fast to keep the room setpoint stable.
- » Gives priority to fast reaction speed. The refrigerant temperature goes down fast to keep the room setpoint stable.
- » Gives priority to efficiency. The refrigerant temperature goes down gradually giving priority to the efficiency of the system instead of the reaction speed.

# Installation Space



## VRV EMERSON | VRV IV X | VRV IV | VRV AURORA

### Installation Space Examples

- » The installation space requirement shown in the figure is a reference for cooling.
- » During installation, install the units using the most appropriate of the patterns shown in the figure for the location in question, taking into consideration human traffic and wind.
- » If the number of units installed is more than that shown in the pattern in the figure, install the units so that there is no air short circuiting.
- » Consider the space needed for the refrigerant piping when installing the units, as determined by local codes.
- » If the space requirements in the figure do not apply, contact your contractor or Daikin directly.

For single unit installation

< Pattern 1 >

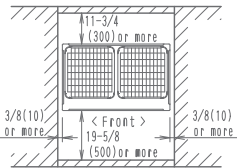

< Pattern 2 >

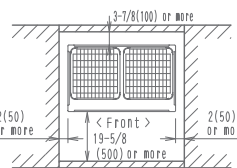

< Pattern 3 >

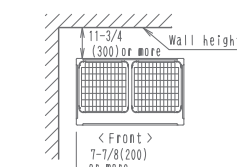

For installation in rows

< Pattern 1 >

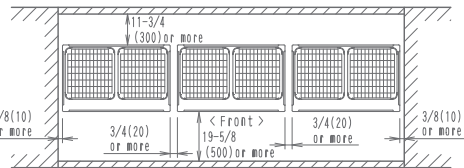

< Pattern 2 >

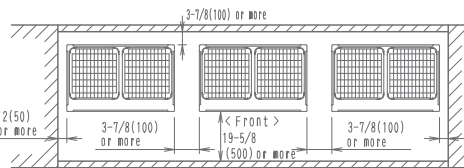

< Pattern 3 >

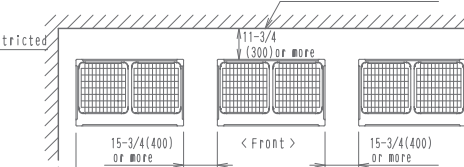

For centralized group layout

< Pattern 1 >

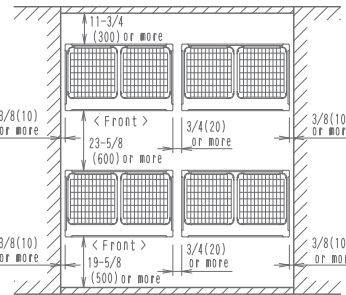

< Pattern 2 >

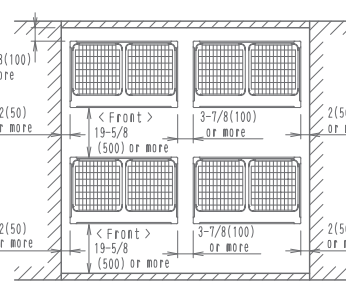

### Notes

1. Heights of walls in case of Patterns 1 and 2:  
Front: 59in  
Suction side: 19-5/8in  
Side: Height unrestricted.  
Installation space shown in this drawing is based on the cooling operation at 95°F outdoor air temperature. When the design outdoor temperature exceeds 95°F or the load exceeds maximum ability because of much generation load of heat in all outdoor unit, take the suction-side space more broadly than the space shown in this drawing.
2. If the above wall heights are exceeded then h2/2 and h1/2 should be added to the front and suction side service spaces respectively as shown in the figure.

3. When installing, the units most appropriate pattern should be selected in order to obtain the best fit in the space available, always bearing in mind the need to leave enough space for a person to pass between the units and wall and for the air to circulate freely.
4. The units should be installed to leave sufficient space at the front for the field refrigerant piping work to be carried out comfortably.

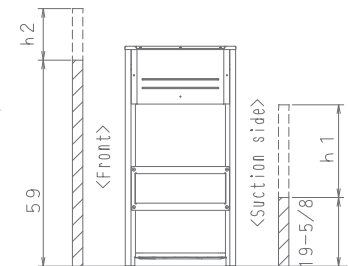



V-Series Water Cooled System

1. In case of a single installation [inch.]
2. In case of multiple unit installation [inch.]
3. Top view
4. Side view
5. Condensing unit
6. Service Space (front side)
7. Service Space (back side)
8. Space for installing water piping must be ample enough to remove the front panel.

9. Ventilation space (refer to Engineering Data Book for further details)
10. Secure spaces in the front, back, and top sides as same as the case of single installation.

11. Service space above the unit for refrigerant piping (refer to Engineering Data Book for further details)

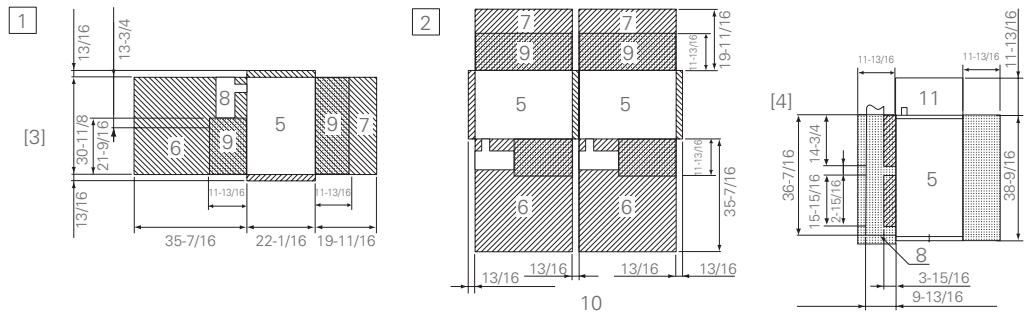

## VRV IV S-series

In case of series installation, some space between the units is needed for wiring with conduit and servicing.

1. Where there is an obstacle on the suction side:

- (a) No obstacle above
  - (1) Stand alone installation
    - Obstacle on the suction side only
    - Obstacle on both sides

2. Where there is an obstacle on the discharge side:

- (a) No obstacle above
  - (1) Stand alone installation

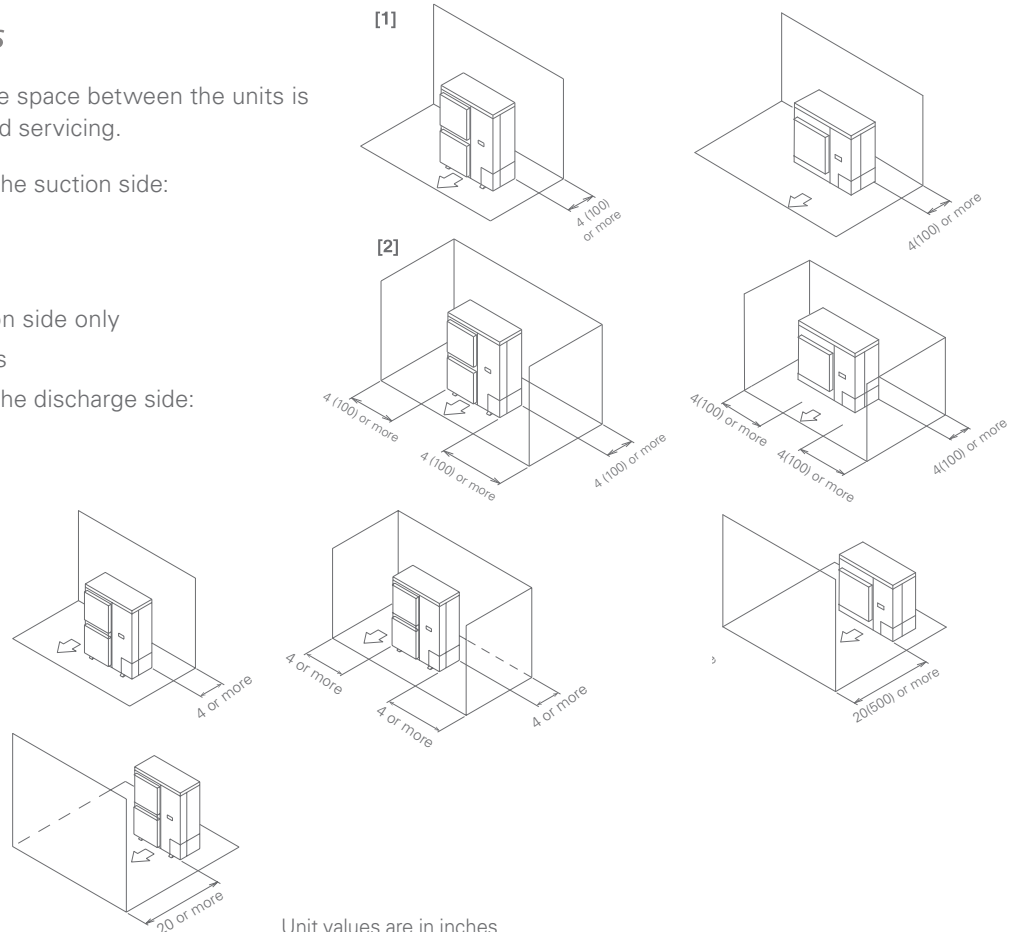

Unit values are in inches

# Piping Length



The long piping length provides more design flexibility, which can match even large-sized buildings.

## Air-cooled system piping length

For connection of only VRV indoor units

	VRV EMERION, VRV IV X, VRV IV & VRV AURORA	VRV IV-S
Max. actual piping length	541 ft.	230 ft. (3-Ton: 164 ft.)
Max. equivalent piping length	623 ft.	295 ft. (3-Ton: 213 ft.)
Max. total piping length	3281 ft. (AURORA: 1640 ft.)	984 ft. (3-Ton: 820 ft.)
Max. level difference between the outdoor units and the indoor units	295 ft. <sup>†</sup> (EMERION: 361 ft.)	98 ft.
Max. level difference between the indoor units	100 ft. <sup>*</sup>	49 ft. (3-Ton: 33 ft.)
Max. distance from 1st refrigerant branch joint	295 ft.	130 ft.

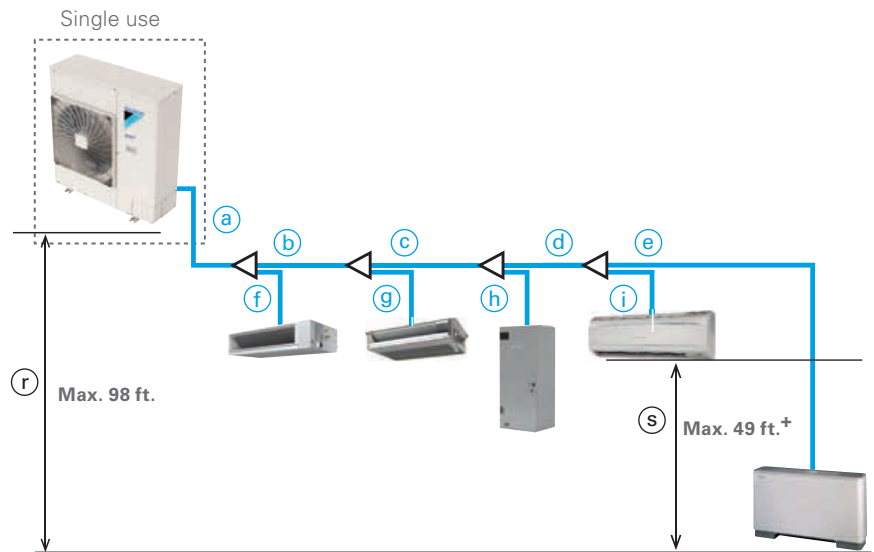

Piping for VRV EMERION VRV IV X, VRV IV, VRV AURORA, and VRV IV-S

		ACTUAL PIPING LENGTH		EXAMPLE	EQUIVALENT PIPING LENGTH	
		VRV EMERION, VRV IV X/ VRV IV/ VRV AURORA	VRV IV-S		VRV EMERION, VRV IV X/ VRV IV/ VRV AURORA	VRV IV-S
Maximum allowable piping length	Refrigerant piping length	541 ft.	164 ft. 230 ft.	a+b+c+d+e	623 ft	213 ft 295 ft
	Total piping length	3281 ft. AURORA: 1640 ft.	820 ft. 984 ft.	a+b+c+d+e+f+g+h+i	—	—
	Between the first indoor unit branch and the farthest indoor unit	295 ft. <sup>*</sup>	98 ft. 98 ft.	b+c+d+e	—	—

		LEVEL DIFFERENCE		EXAMPLE	
		VRV EMERION, VRV IV X/ VRV IV/ VRV AURORA	VRV IV-S		
Maximum allowable level difference	Between the outdoor units (multiple use on the same circuit)	16 ft.	n/a n/a	—	
	Between the indoor units	98 ft.	33 49	s	
	Between the outdoor units and the indoor units	If the outdoor unit is above	295 ft. (EMERION: 361 ft.) <sup>†</sup>	98 98	r
		If the outdoor unit is below	295 ft. (EMERION: 361 ft.) <sup>†</sup>	98 98	r

\* No special requirements up to 131 ft. The maximum actual piping length can be 295 ft., depending on conditions. Various conditions and requirements have to be met to allow utilization of 295 ft. piping length. Be sure to refer to the Engineering Data Book for details of these conditions and requirements.

† Refer to installation manuals for details of the conditions and requirements



## Water-cooled system piping length

Water-Cooled systems provide considerable design flexibility with total piping lengths of up to 980 ft. and vertical separation of up to 164 ft.\* between condensing units and indoor units.

For connection of only VRV indoor units

Actual piping length between the VRV T-Series and indoor units: 540ft. (equivalent piping length: 623ft.)

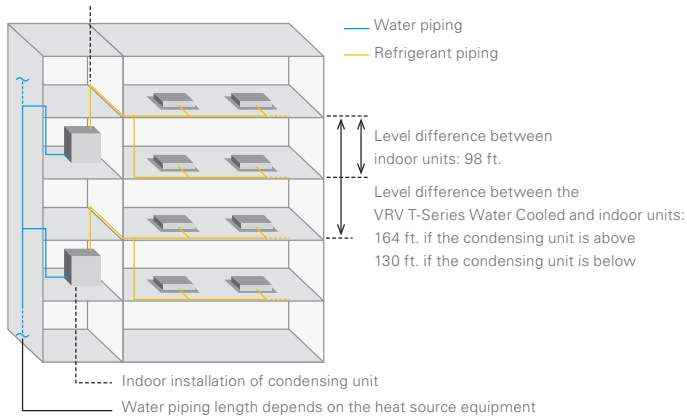

REFRIGERANT PIPING LIMITATIONS	LIMITATIONS
Linear piping between condensing unit and furthest located fan coil unit (equivalent), ft.	540 (623)
Total "one-way" piping in the complete piping network, ft.	980
Vertical (height) separation between the condensing unit and the fan coil units (if condensing unit is below)*, ft.	164 (130)
Vertical (height) separation between fan coil units, ft.	98
Linear piping between 1st <i>REFNET</i> and furthest located fan coil unit, ft.	130 (295)**

\* Conditions apply when the condenser is lower than indoor units. Refer to your local Daikin representative for further information.

\*\* Conditions/rules apply. Refer to Installation manual for further details.



## VRV Accessories

### Branch Selector Boxes

#### New Flex Branch Selector for Ultimate Flexibility

Daikin's new *Flex Branch Selector* boxes are engineered to be compact and provide flexibility in design, installation, maintenance, and service. Packed with Daikin's state of the art technology, the new *Flex Branch Selector* boxes fit in tight mechanical spaces (common in ceilings) combined with flexibility in piping configuration and movable E-box makes the new design an ideal choice for commercial buildings.

#### Main Features and Benefits

##### Flexible

- » Design flexibility with versatile piping configurations of Left or Right or Pass through layouts.
- » Engineered for tight ceiling spaces with a compact height of 9½" and 0"¹ service clearance between the slab and the top of the *Flex Branch Selector* box.
- » Flexibility to expand design with up to 121 ports and 230Mbh¹ down stream capacity by connecting multiple boxes in series.
- » Ability to optimize installed system cost by reducing *REFNETs* and braze joints in pass thru configuration vs non-pass through configuration.
- » Simple electrical configurations with flexibility to re-position E-box.²
- » Ability to mix and match Daikin *Flex Branch Selector* boxes and standard branch selector box for ultimate design flexibility.

¹ Refer to engineering manuals for design rules

² Feature available for BSF4Q54TVJ (4-port) model only

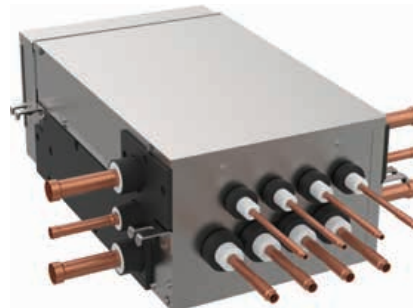

##### Installation Flexibility

- » Ease of maintenance with access to electronic expansion valve (EEV) heads and motor via side access panel.
- » Eliminate cross piping with refrigerant pipe identification labels.
- » Simple electrical and communication wiring with connection from the front side of E-box.²

##### Innovative

- » Daikin's high specification EEV enables precise refrigerant control for high comfort in user spaces and reliable system operation.
- » Hermetically sealed to prevent condensate build up within the unit, eliminating the need for a condensate drain pan and plumbing connections for a simple installation.
- » Low ambient cooling down to -4°F¹ for simple and integrated system design.

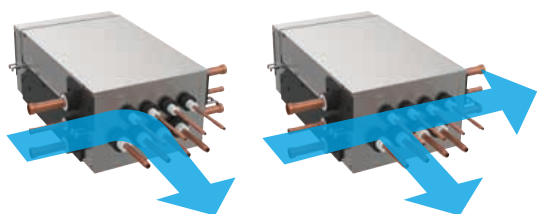

From Left

Left and  
Pass Thru

OR

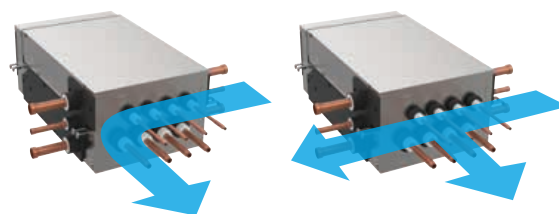

From Right

Right and  
Pass Thru

Factory Default Rear E-box

Field Convertible to Left Sided

Field Convertible to Right Sided

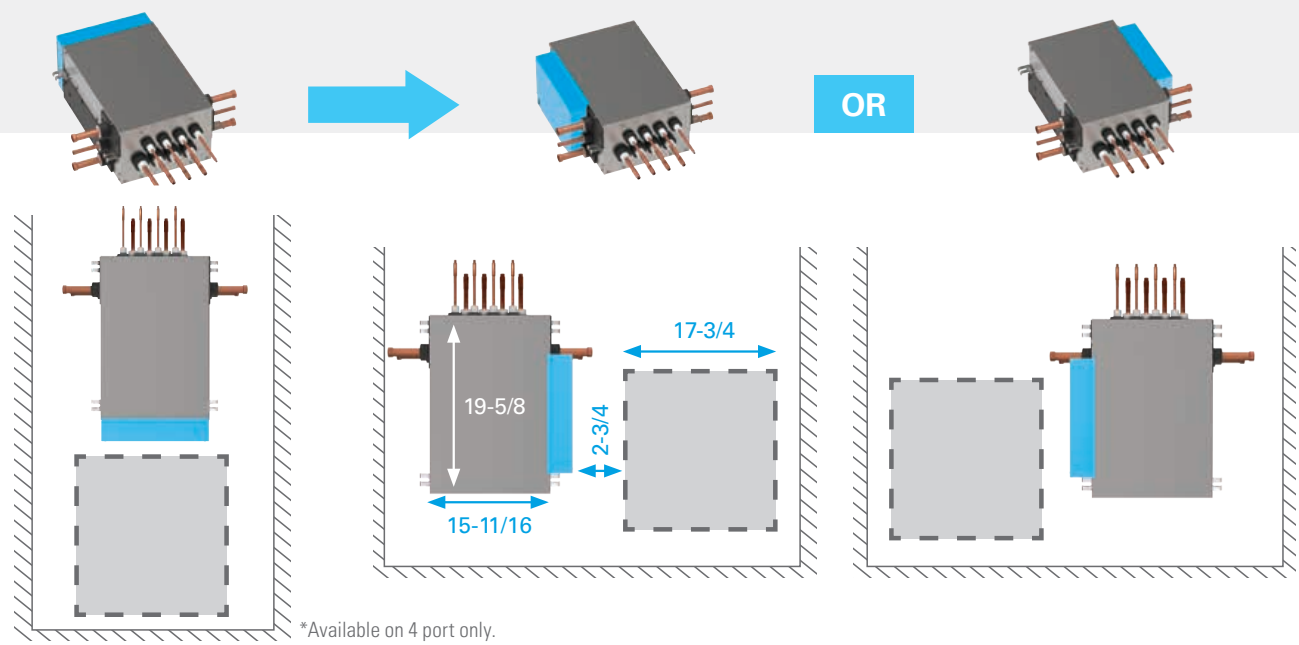

**TECHNICAL DATA FOR MULTI-PORT BRANCH SELECTOR BOXES**

Model				BSF4Q54TVJ	BSF6Q54TVJ	BSF8Q54TVJ
Number of Branches				4	6	8
Maximum capacity index per branch				54		
Max Total Capacity Index when in Parallel/ when in Series				144	216 / 162	290 / 162
Max Number of Connectable Indoor Units Per Branch				5		
Max total capacity Index under BS Units Connected in Series				230		
Connecting Pipes	Indoor Unit	Liquid	in.	3/8 (1/4) Brazing		
		Gas	in.	5/8 (1/2) Brazing		
	Outdoor unit	Liquid	in.	5/8 Brazing		
		Suction Gas	in.	1-1/8 Brazing		
		HP/LP Gas	in.	1-1/8 Brazing		
Electrical	Power Supply		ph/V/Hz	Single phase / 208-230V / 60Hz		
	Maximum Overcurrent Protection, MOP		A	15		
	Minimum Circuit Amps, MCA		A	0.4	0.6	0.8
Sound Level	Operating sound		dB (A)	37	40.5	40.5
	Max. sound		dB (A)	47	50	50
Weight			lbs.	49	73	81
Dimensions (H x W x D)			in.	9-1/2 x 13-3/4 x 23-3/4		9-1/2 x 23-3/8 x 23-3/4

**MULTI-PORT BRANCH SELECTOR BOX INSTALLATION SPACE**

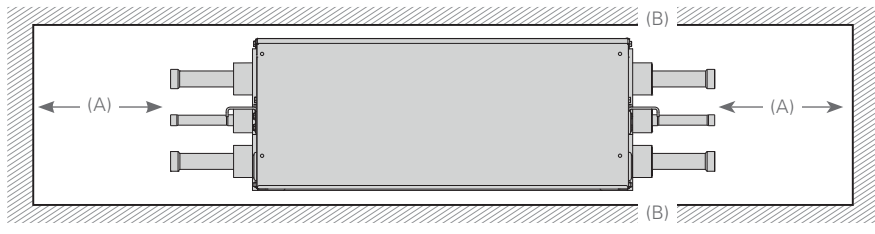

MINIMUM CLEARNACE	BSF4Q54TVJ	BSF6Q54TVJ	BSF8Q54TVJ
A	in.	20	
B	in.	3/16	

## VRV Accessories

### Branch Selector Boxes (cont.)

#### Branch Selector Boxes for Heat Recovery Systems

Providing flexibility and minimizing mechanical and electrical installation costs, Daikin's branch selector boxes are ideal for spaces that require individual heating and cooling control.

- » New *Flex Branch Selector* models offered in 4, 6, and 8 port.
- » Ability to connect multiple branch selector boxes in series or in parallel when using *Flex Branch Selector* Box
- » Extend phase installation capability of *VRV EMERION* and *VRV IV X* by leveraging *Flex Branch Selector* box ability to add on additional boxes in series
- » Wide range of product offerings with 1, 4, 6, 8, 10 and 12 port options
- » No drain or condensate consideration required
- » Unlimited number of unused ports per box or system
- » Reduce electrical and mechanical installation costs
- » Ultimate flexibility – Choose multi-port or single-port styles to customize your design

#### Branch Selector Boxes Compatibility

Single-Port and Multi-Port Branch Selector Boxes BS-TVJ and BSF-TVJ series are compatible with *VRV EMERION*, *VRV IV X*, *VRV IV* and *VRV T-Series* Water-Cooled Heat Recovery Units.

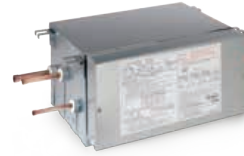

BSQ36TAVJ, BSQ60TAVJ,  
& BSQ96TAVJ Single Port

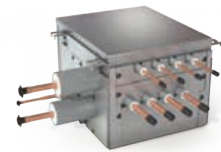

BS4Q54TAVJ



BS6Q54TAVJ, BS8Q54TVJ



BS10Q54TVJ, BS12Q54TAVJ

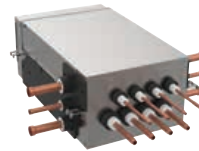

BSF4Q54TVJ

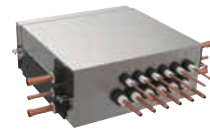

BSF6Q54TVJ



BSF8Q54TVJ

Daikin's branch selector boxes are ideal for spaces that require individual heating and cooling control.



## STANDARD MULTI-PORT T-SERIES

### TECHNICAL DATA - MULTI-PORT T-SERIES BRANCH SELECTOR BOXES

Model			BS4Q54TAVJ	BS10Q54TAVJ	BS12Q54TAVJ	
Number of branches			4	10	12	
Maximum capacity index per branch				54		
Maximum total capacity index			144	290		
Maximum connectable indoor units per branch				5		
Connecting Pipes	IU	Liquid	in.	Ø1/4, Ø3/8		
		Gas	in.	Ø1/2, Ø5/8		
	OU	Liquid	in.	Ø3/8	Ø5/8	
		Suction Gas	in.	Ø7/8	Ø1-1/8	
		HP/LP Gas	in.	Ø3/4	Ø1-1/8	
Electrical	Power Supply		ph/V/Hz	1/208-230/60		
	Maximum Overcurrent Protection, MOP		A	15		
	Minimum Circuit Amps, MCA		A	1	1.2	
Mass (Weight)			lbs.	49	101	
Dimensions (H x W x D)			in.	11-3/4 x 14-9/16 x 18-15/16		

### STANDARD T-SERIES MULTI PORT BRANCH SELECTOR BOXES INSTALLATION SPACE

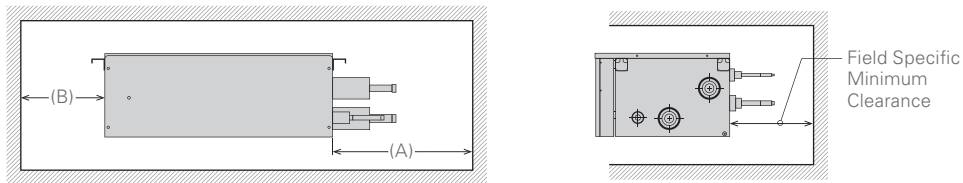

MINIMUM CLEARANCE		BS4Q54TAVJ	BS10Q54TAVJ	BS12Q54TAVJ
A	in.		20	
B	in.	11-3/4		

## SINGLE PORT BRANCH SELECTOR BOXES

### TECHNICAL DATA FOR SINGLE-PORT BRANCH SELECTOR BOXES

Model			BSQ36TAVJ	BSQ60TAVJ	BSQ96TAVJ
Number of branches			1	1	1
Maximum capacity index			36	60	96
Maximum connectable indoor units			4	8	8
Connecting Pipes	IU	Liquid	in.	Ø3/8	
		Gas	in.	Ø5/8	Ø7/8
	OU	Liquid	in.	Ø3/8	
		Suction Gas	in.	Ø5/8	Ø7/8
		HP/LP Gas	in.	Ø1/2	Ø3/4
Electrical	Power Supply		ph/V/Hz	1/208-230/60	
	Maximum Overcurrent Protection, MOP		A	15	
	Minimum Circuit Amps, MCA		A	0.1	
Mass (Weight)			lbs.	24	31
Dimensions (H x W x D)			in.	8-1/8 x 15-1/4 x 12-13/16	

### SINGLE-PORT BRANCH SELECTOR BOX INSTALLATION SPACE

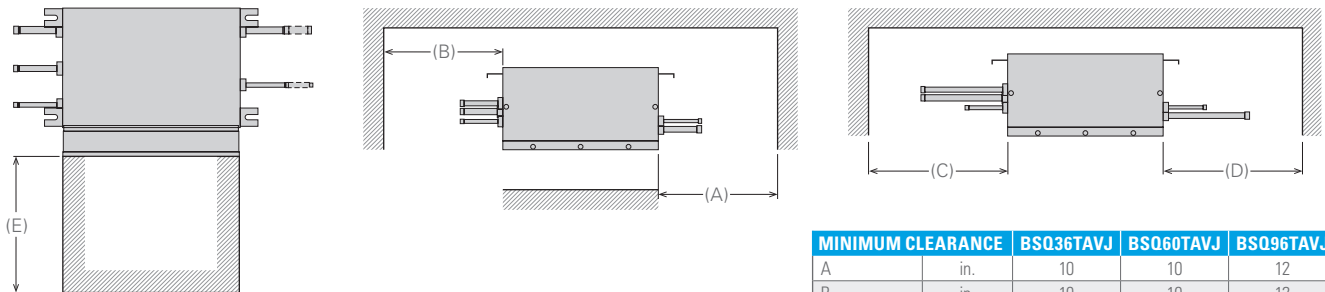

MINIMUM CLEARANCE		BSQ36TAVJ	BSQ60TAVJ	BSQ96TAVJ
A	in.	10	10	12
B	in.	10	10	12
C	in.	-	13-3/4	15-3/4
D	in.	12	13-3/4	15-3/4
E	in.	12	12	11-13/16

For additional technical information and all equipment installation and application limitations please refer to the specific Engineering Data Books.

# VRV Accessories

## REFNET | Pipe Joints

### REFNET

REFNET joints distribute correct flow of refrigerant in every branch of the piping network. Sourced locally and complies to ASTM E-84 Class A low flame and smoke spread index requirements.



REFNET Joint



REFNET Header

### VRV IV X, VRV IV / VRV AURORA Heat Pump

OPTIONAL ACCESSORIES		RXYQ72 - 96T RXYQ72 - 96X RXLQ72 - 96T	RXYQ120-168T RXYQ120-168X RXLQ120T	RXYQ192-336T RXYQ192-336X RXLQ144-240T	RXYQ360-408T RXYQ360-408X RXYQ360-480MBH
Distributed piping	REFNET Header	KHRP26M22H (max. 4 branch) KHRP26M33H (max. 8 branch)	KHRP26M22H (max. 4 branch) KHRP26M33H (max. 8 branch) KHRP26M72H (max. 8 branch)	KHRP26M22H (max. 4 branch) KHRP26M33H (max. 8 branch) KHRP26M72H (max. 8 branch) KHRP26M73HU (max. 8 branch)	KHRP26M22H (max. 4 branch) KHRP26M33H (max. 8 branch) KHRP26M72H (max. 8 branch) KHRP26M73HU (max. 8 branch)
	REFNET Joint	KHRP26A22T, KHRP26A33T	KHRP26A22T, KHRP26A33T, KHRP26M72TU	KHRP26A22T, KHRP26A33T, KHRP26M72TU, KHRP26M73TU	KHRP26A22T, KHRP26A33T, KHRP26M72TU, KHRP26M73TU
Outdoor unit multi connection piping kit		—		BHFP22P100U	BHFP22P151U

### VRV EMERION / VRV IV X / VRV IV / VRV AURORA Heat Recovery

OPTIONAL ACCESSORIES		REYQ72 - 96A REYQ72 - 96X RELQ72 - 96T	REYQ120-168A REYQ120-168X REYQ120-168T	REYQ192-480A REYQ192-336X REYQ192-336T	REYQ360-456X REYQ360-456T
Distributed piping	REFNET header	KHRP25M33H (max. 8 branch)	KHRP25M33H (max. 8 branch) KHRP25M72H (max. 8 branch)	KHRP25M33H (max. 8 branch) KHRP25M72H (max. 8 branch) KHRP25M73HU (max. 8 branch)	KHRP25M33H (max. 8 branch) KHRP25M72H (max. 8 branch) KHRP25M73HU (max. 8 branch)
	REFNET joint	KHRP25A22T KHRP25A33T	KHRP25A22T KHRP25A33T KHRP25M72TU	KHRP25A22T KHRP25A33T KHRP25M72TU KHRP25M73TU	KHRP25A22T KHRP25A33T KHRP25M72TU KHRP25M73TU
Outdoor unit multi connection piping kit		—		BHFP26P100U <sup>1</sup>	BHFP26P151U

<sup>1</sup>Reducer pipe kit KHFP26P100UA is required for REYQ264-480A models

### VRV T-Series Water-Cooled Heat Pump / Heat Recovery and VRV IV-S

UNIT MODEL NUMBER	VRV T-SERIES WATER-COOLED					VRV IV-S
	RWEQ96T	RWEQ120T	RWEQ144T	RWEQ192 - 288T	RWEQ312 - 432T	RXTQ36TAVJ9A RXTQ48TAVJUA RXTQ60TAVJUA
REFNET Header	Heat Pump	KHRP26M22H (Max 4 branch) KHRP26M33H (Max 8 branch)	KHRP26M22H (Max 4 branch), KHRP26M33H (Max 8 branch) KHRP26M72H (Max 8 branch)	KHRP26M22H (Max 4 branch), KHRP26M33H (Max 8 branch) KHRP26M72H (Max 8 branch), KHRP26M73HU (Max 8 branch)	KHRP26M22H (Max. 4 branch) KHRP26M33H (Max. 8 branch)	KHRP26M22H (Max. 4 branch) KHRP26M33H (Max. 8 branch)
	Heat Recovery	KHRP25M33H (Max 8 branch)	KHRP25M33H (Max 8 branch) KHRP25M72H (Max 8 branch)	KHRP25M33H (Max 8 branch), KHRP25M72H (Max 8 branch) KHRP25M73HU (Max 8 branch)	—	—
REFNET Joint	Heat Pump	KHRP26A22T, KHRP26A33T	KHRP26A22T, KHRP26A33T, KHRP26M72TU	KHRP26A22T, KHRP26A33T, KHRP26M72TU, KHRP26M73TU	KHRP26A22T	KHRP26A22T
	Heat Recovery	KHRP25A22T, KHRP25A33T	KHRP25A22T, KHRP25A33T, KHRP25M72TU	KHRP25A22T, KHRP25A33T, KHRP25M72TU, KHRP25M73TU	—	—
Outdoor Unit Multi Piping Connection Kit	Heat Pump	—	—	BHFP22T84U	BHFP22T126U	—
	Heat Recovery	—	—	BHFP26T84U	BHFP26T126U	—

### Hail Guard Kits

The optional hail guard kit for VRV3-phase enables optimal airflow for efficient heat transfer while providing condenser coil protection from hail damage in severe climates. Each hail guard kit, that is field installed, consists of 4 panels (Right, Left, Front and Back).

#### Hail Guard Kit for VRV IV X, VRV IV, and VRV AURORA

VRV IV	QUANTITY OF KITS PER ODU MODELS					PANEL DIMENSIONS (H X W X D)			
	R_YQ72T	R_YQ96-168T	R_YQ192T	R_YQ216-336T	R_YQ360-456T	Right Panel	Left Panel	Front Panel	Front Panel
VRV AURORA		R_LQ72-120T		R_LQ144-240T					
VRV IV X HP	RXYQ72X	RXYQ96-168X	RXYQ192X	RXYQ216-336X	RXYQ360-456X				
VRV IV X HR		REYQ72-168X		REYQ192-336X	REYQ360-408X				
VRV4HGS-K1	1		1			45 <sup>7</sup> / <sub>8</sub> " x 26" x 4"	45 <sup>7</sup> / <sub>8</sub> " x 12 <sup>7</sup> / <sub>8</sub> " x 4"	45 <sup>7</sup> / <sub>8</sub> " x 13 <sup>1</sup> / <sub>4</sub> " x 4"	45 <sup>7</sup> / <sub>8</sub> " x 32 <sup>5</sup> / <sub>8</sub> " x 4"
VRV4HGL-K1		1	1	2	3			45 <sup>7</sup> / <sub>8</sub> " x 24" x 4"	45 <sup>7</sup> / <sub>8</sub> " x 44 <sup>3</sup> / <sub>4</sub> " x 4"

\*Refer engineering and installation manual for more detail.

#### Hail Guard Kit for VRV EMERION

VRV EMERION	QUANTITY OF KITS PER ODU MODELS		
	RXYQ72A / REYQ72A	RXYQ96-168A / REYQ96-168A	RXYQ192-240A / REYQ192-240A-240A
VRV6HGM-K1	1		
VRV6HGL-K1		1	
VRV6HGXL-K1			1



### Snow/Wind Hood Kits

The optional Snow/Wind Hood Kits mount over the heat exchanger coil to protect from snow build-up and wind in cold climates. The Hoods install easily to condensing units using existing screw taps with no modification required. Different kits can be ordered for different job requirements.

VRV IV X, AURORA	KIT PART NUMBER	CHASSIS SIZE	KIT INCLUSION	
	VRV-SHS-FR	Small Chassis	Front Hood	Rear Hood
VRV-SHL-FR	Large Chassis	Front Hood	Rear Hood	
VRV-SH-RL	Both Chassis	Right Hood	Left Hood	
VRV-SHS-T	Small Chassis		Top Hood	
VRV-SHL-T	Large Chassis		Top Hood	

VRV EMERION	KIT PART NUMBER	CHASSIS SIZE	KIT INCLUSION	
	VRV6-SHM-FR	Medium Chassis	Front Hood	Rear Hood
VRV6-SHL-FR	Large Chassis	Front Hood	Rear Hood	
VRV6-SHXL-FR	X-Large Chassis	Front Hood	Rear Hood	
VRV6-SH-RL	All Chassis	Right Hood	Left Hood	
VRV6-SHM-T	Medium Chassis		Top Hood	
VRV6-SHL-T	Large Chassis		Top Hood	
VRV6-SHXL-T	X-Large Chassis		Top Hood	

MODEL TYPE		NUMBER OF KITS REQUIRED FOR EACH OUTDOOR SYSTEM												
		NUMBER OF MODULES	VRV6-SHM-FR	VRV6-SHL-FR	VRV6-SHXL-FR	VRV6-SHM-T	VRV6-SHL-T	VRV6-SHXL-T	VRV6-SH-RL	VRV6-SHS-FR	VRV6-SHL-FR	VRV6-SH-RL	VRV6-SHS-T	VRV6-SHL-T
VRV EMERION	208-230V /460V	RXYQ72A, REYQ72A	Single	1			1			1				
		RXYQ96-168A, REYQ96-168A	Single		1		1		1					
		RXYQ196-240A, REYQ196-240A	Single			1			1	1				
		RXYQ264-336A, REYQ264-336A	Dual		2			2		1				
		RXYQ360A, REYQ360A	Dual		1	1		1	1	1				
VRV AURORA	208-230V /460V / 575V	R_LQ72-120T	Single								1	1		1
		R_LQ144-240T	Dual								2	1		2
VRV IV Heat Recovery Heat Pump	208-230V / 460V	R_YQ72T	Single							1		1	1	
		R_YQ96-168T	Single								1	1	1	1
		R_YQ192T	Dual							1	1	1	1	1
		R_YQ216-336T	Dual								2	1	1	2
		R_YQ360-456T*	Triple								3	1	1	3
VRV IV X Heat Recovery	208-230V / 460V	REYQ72-168X	Single								1	1	1	
		REYQ192-336X	Dual								2	1	1	2
		REYQ360-456X	Triple								3	1	1	3
VRV IV X Heat Pump	208-230V / 460V	RXYQ72X	Single							1		1	1	
		RXYQ96-168X	Single								1	1	1	1
		RXYQ192X	Dual							1	1	1	1	1
		RXYQ216-336X	Dual								2	1	1	2
		RXYQ360-408X	Triple							3	1	1	3	

\*Up to 408 on Heat Pump

# Air Handling Unit (AHU) Integration Kit



## Designed for High Efficiency

The Daikin Air Handling Unit Integration Kit enables a non-VRV Air Handling Unit to be fully integrated into a Daikin VRV system, allowing the benefits of inverter technology to extend to custom terminal units and air handling equipment.

Designed for high system efficiency, the Air Handling Unit Integration Kit offers a seamless integration and optimized design flexibility for Air Handling Units while keeping total installation and commissioning time to a minimum.

A kit consists of one Control Box and one EEV Box. Two different control methods can be used for an evaporator coil of up to 16 tons.

## Features and Benefits

- » Enables non-VRV Air Handling Units to be seamlessly integrated into a Daikin VRV system
- » Integrates to VRV Heat Pump and Heat Recovery systems\*
- » Daikin DIII-NET communication compatible — can be used with both Daikin *iTM* and *Navigation* controller
- » Separate Control Box and EEV Box accommodates flexible installation
- » Available with two control methods:
  - EKEQMCAV3-US (Z-Control)
  - Standard VRV indoor unit room temperature control
  - EKEQFCBAV3-US (W-Control)
  - Field supplied temperature sensor
  - Field supplied DDC controller with 0-10V capability)

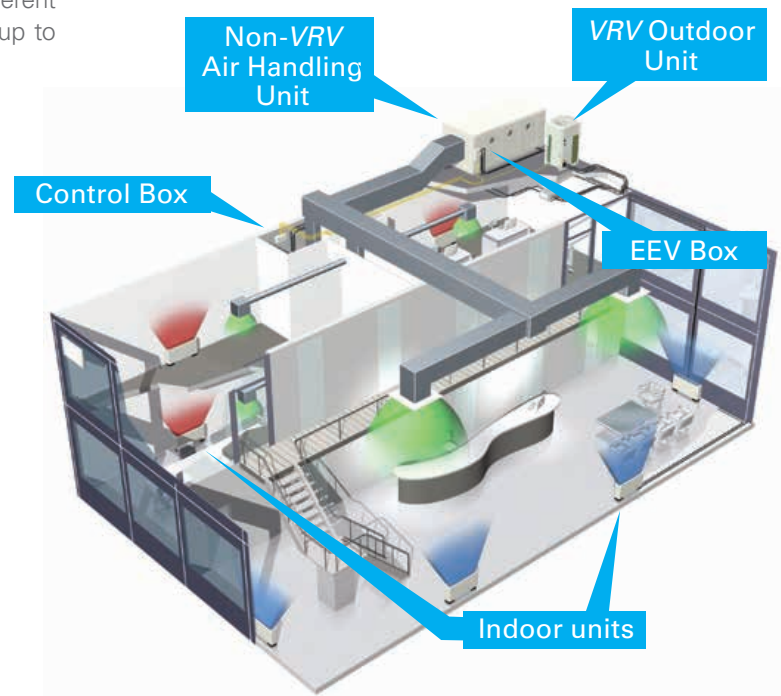
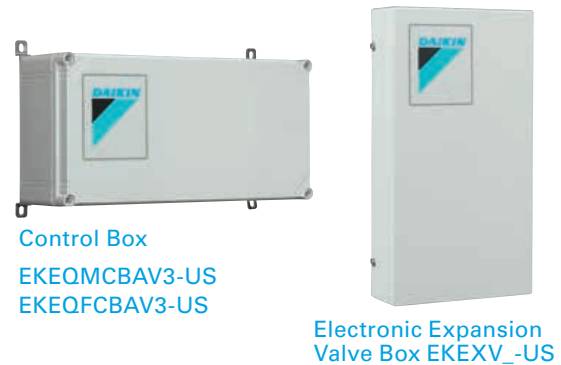

\* Important! For any VRV systems that utilize the AHU integration kits to perform as intended, the DX coil(s) in the non-VRV AHU unit(s) must meet the range of criteria set forth in the AHU Integration Kit Selection Guide and all associated piping and combination rules (refer to IOD-7041A and IOD-7042A), and should be installed in accordance to the installation manual provided with the EKEQ control boxes.





ELECTRONIC EXPANSION VALVE BOX SPECIFICATIONS		EKE XV50-US	EKE XV63-US	EKE XV80-US	EKE XV100-US	EKE XV125-US	EKE XV140-US	EKE XV200-US	EKE XV250-US	EKE XV400-US	EKE XV500-US
Nominal Capacity	BTU/h	18,000	24,000	30,000	36,000	48,000	60,000	72,000	96,000	144,000	192,000
AHU Heat Exchanger Cooling Capacity Range	BTU/h	17,000-21,000	21,500-26,500	27,000-34,500	34,000-42,000	42,500-52,500	53,000-60,000	60,500-84,000	84,500-105,000	120,000-169,000	170,000-210,000
AHU Heat Exchanger Heating Capacity Range	BTU/h	19,000-24,000	24,200-30,000	30,500-38,000	38,500-47,000	47,500-59,000	59,500-67,500	68,000-94,500	95,000-118,500	136,000-187,500	188,000-236,500
AHU Heat Exchanger Refrigerant Volume Range	in <sup>3</sup>	46-100	101-126	127-161	162-201	202-251	252-281	282-402	403-503	564-804	806-1006
Power Supply	V/ph/Hz	208-230/1/60									
Weight	lbs.	6.4									
Height	in.	15-3/4									
Width	in.	8-1/2									
Depth	in.	3-1/16									
Pipe Connections	in.	1/2 x 1/4	3/8 x 5/8				3/4 x 3/8		7/8 x 3/8	1-1/8 x 1/2	1-1/8 x 5/8

\* Important! For any VRV systems that utilize the AHU integration kits to perform as intended, the DX coil(s) in the non-VRV AHU unit(s) must meet the range of criteria set forth in the AHU Integration Kit Selection Guide and all associated piping and combination rules (refer to IOD-7041A and IOD-7042A), and should be installed in accordance to the installation manual provided with the EKEQ control boxes.



### Features and Benefits

- » Designed for both indoor and outdoor installation
- » Equipped with refrigerant filters on both sides of the expansion valve
- » Can be mounted up to 16 ft (5m) away from the air handling unit
- » Simplified installation with inlet and outlet brazed connections
- » Wide range that covers from 1.5 ton to 16 ton
- » Same EEVs as used in standard VRV Indoor product to deliver precise refrigerant control

# Control Box

## EKE\_CBAV3-US



### EKEQMCBAV3 - US

For use with both Daikin VRV indoor units and custom air handling units

- » Allows for discharge air control
- » Seamless integration of non-VRV air handling units with VRV IVHP and HR systems
- » Enables control of the AHU as a VRV Indoor unit when integrated with a Daikin remote control
- » Connect other VRV indoor units along with the AHU to the condensing units
- » Provides remote ON/OFF option when integrated with optional KRP4A71 board
- » Designed for both indoor and outdoor installations

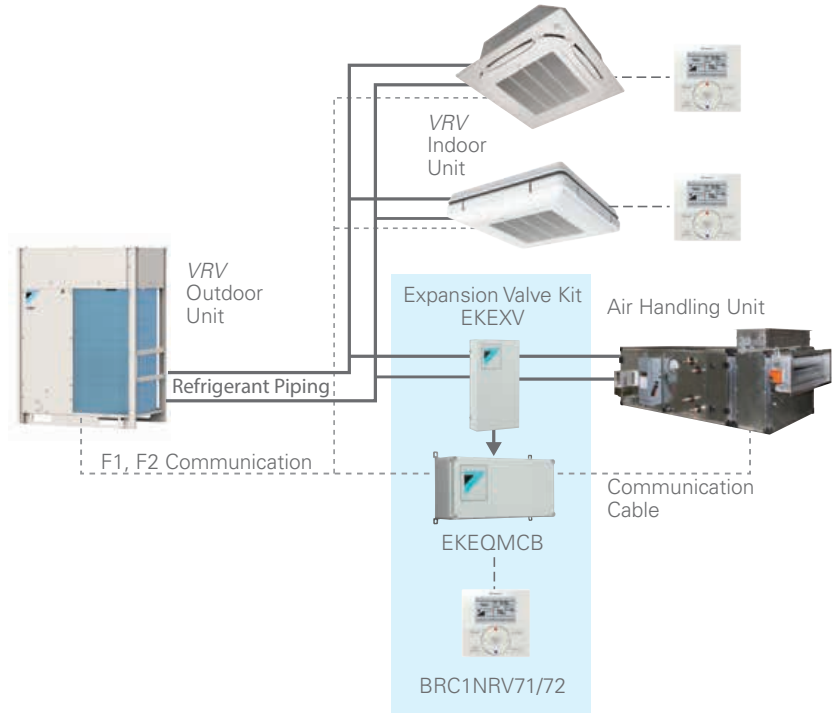

### EKEQFCBAV3 - US

For use with custom air handling units only

- » Seamlessly integrate non-VRV air handling units with VRV IVHP
- » Best suited for applications where 1 AHU is connected to 1 VRV system only
- » Connect up to 3 integration kits per VRV system to serve a large capacity AHU
- » Unified cooling and heating mode programming
- » Enables control of AHU unit using field temperature sensor and 0-10V field supplied DDC controller
- » Allows for discharge air temperature control

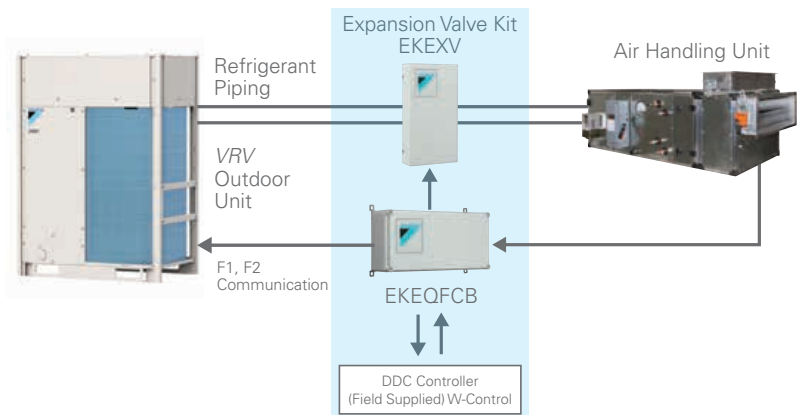



CONTROL BOX SPECIFICATIONS		EKEQMCBAV3-US (Z-Control)	EKEQFCBAV3-US (W-CONTROL)
Entering Air Temperature Limits	Cooling °F	57 WB - 77 WB	106 DB/90 WB
	Heating °F	50 DB - 80 DB	Min of 23 DB
Power Supply	V/ph/Hz	208-230/1/60	
Weight	lbs.	8	8.6
Height	in.	5-13/64	
Width	in.	15-3/4	
Depth	in.	9-3/8	
Connection Ratio		50 - 110%	90 - 110%
Max Piping Distance	EKEV to AHU	16 ft.	16ft.
	ODU to AHU	Standard VRF/outdoor unit piping limitations based on model selection apply	
Max number of IDU/system			
VRF/IDU + AHU		64	Not available
AHU Only		32	1

\*Capacity de-rate applies beyond 164 ft

**VRV System Compatibility**

VRV System			AHU Integration Kit Type	
VRV System Type	Type	Series	EKEQMCBAV3-US	EKEQFCBAV3-US
			Z-Control	W-Control
Air-Cooled all voltages (3-Phase)	Heat Pump	RXYQ_PB		
		RXYQ_T*	√	√
		RXLQ_T*	√	√
		RXYQ_X*	√	√
	Heat Recovery	REYQ_PB		
		REYQ_PC	√	
		REYQ_T*	√	
		RELO_T*	√	
Air-Cooled all voltages (1-Phase)	Heat Pump	RXYMQ_P		
		RXTQ_T*	√	√
Water-Cooled all voltages (3-Phase)	Heat Pump	RWEYQ_P		
		RWEYQ_PC	√	√
		RWEQT*	√	√
	Heat Recovery	RWEYQ_P	√	
		RWEYQ_PC	√	
		RWEQT*	√	





# Ventilation







Daikin's Outside Air Processing Unit can be integrated with a VRV system to provide outside air treatment and air conditioning in a single system to meet code requirements. It adjusts the temperature of air from outdoors using a fixed discharge temperature control reducing air conditioning load.

In addition to Outside Air Processing Units, we also offer Energy Heat Recovery units. The Energy Heat Recovery VAM-GVJU series units combines compactness, energy conservation, and extensive operation range of outdoor temperatures. This series provides higher enthalpy efficiency, due to the greatly enhanced performance of the thin heat exchanging element. Furthermore, improved external static pressure offers more flexibility for installation.



		OUTSIDE AIR PROCESSING UNIT, FXMQ_MFVJU	ENERGY RECOVERY VENTILATOR, VAM-GVJU
			
VRV Refrigerant Piping		Connectable	Not connectable
VRV Control Wiring		Connectable	
High Efficiency Filter (MERV 8 and MERV 13)		Option	Not available
Ventilation System		Air supply	Air supply and Air exhaust
Power Supply	V/ph/Hz	208-230/1/60	
Airflow Rate	CFM	635 988 1236	305/300/170 470/470/390 600/600/500 1200/1200/930

## FXMQ\_MFVJU

### 100% Outside Air Processing Unit



Outside Air  
Integration Possible

Filter  
Included

### Concealed, Powerful, Compact, Quiet, Fresh Air Quality

This unit provides a zoned, decentralized approach to conditioning outside air. This helps to reduce ductwork and installation time while increasing efficiency and flexibility. Both outside air treatment and space conditioning can be provided from one compact, flexible and efficient VRV system. VRV indoor units and outdoor air processing unit can be connected to the same refrigerant line, enabling enhanced design flexibility.



BRC1H71W  
(option)



BRC1NRV71/72  
(option)

### Features and Benefits

- » Available in three capacities, nominal 48, 72 and 96 MBH
- » The nominal airflow rates are 635, 988, and 1,236 CFM respectively
- » External static pressure capabilities of up to 1.03" W.G. allows for flexibility with duct work and filtration choices
- » The indoor unit is controlled to a set cooling and heating discharge air temperature allowing the flexibility to integrate with a standard Daikin indoor unit or duct directly to the space
- » A low profile design of only 18.5" high reduces the required installation space and can eliminate mechanical rooms or additional structural supports associated with traditional OA systems
- » Indoor Air Quality options include MERV 8 and 13 filters and filter boxes
- » Can be connected to all North American Daikin VRV systems
- » Connects directly and seamlessly into the Daikin local and centralized controllers

### Operational Characteristics

When the suction air temperature is between 66°F and 109°F, the Outside Air Processing Unit operates in cooling, and when between 23°F and 59°F, it operates in heating. The OA processing unit will work in energy saving fan only between 59°F and 66°F.

Layout example

**Outside air processing unit**

for outside air supply

**VRV outdoor unit**

**VRV indoor unit**

for air-conditioning

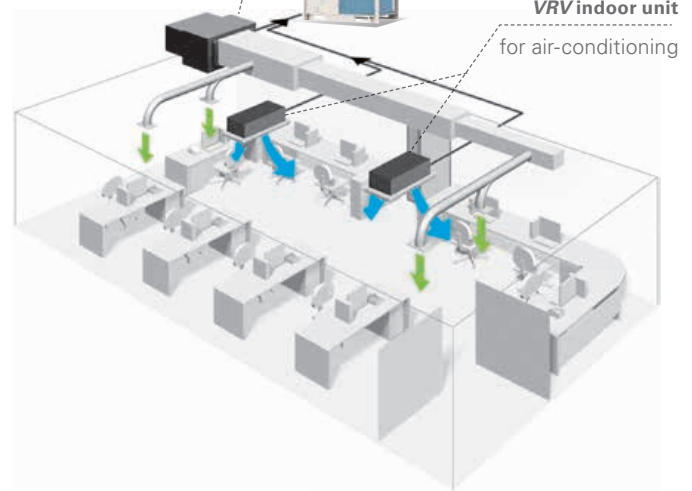

### Applications

- » Hotel/conference centers
- » Schools
- » Retail shopping centers
- » Large open-plan offices
- » Churches

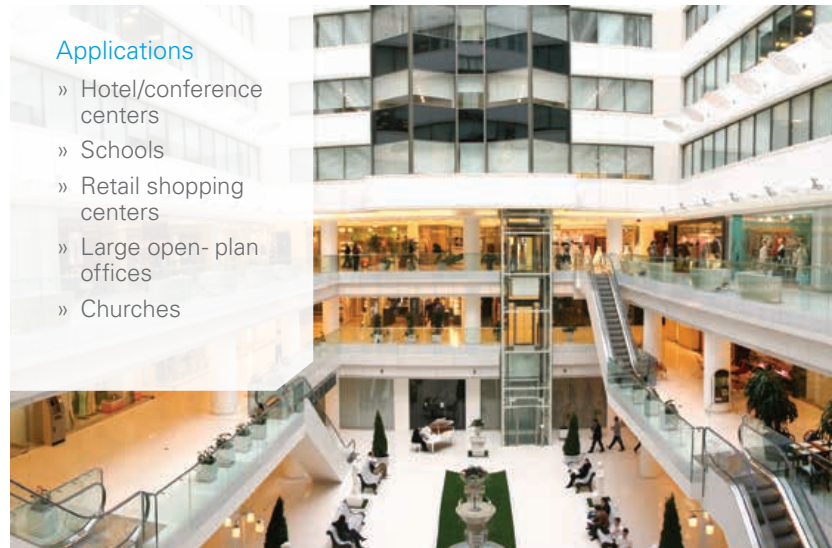

FXMQ_MFVJU SPECIFICATIONS			4 TON	6 TON	8 TON
Model Name			FXMQ48MFVJU	FXMQ72MFVJU	FXMQ96MFVJU
Power Supply	V/ph/Hz		208-230/1/60		
Rated Cooling Capacity	BTU/h		48,000	72,000	96,000
Rated Heating Capacity	BTU/h		30,000	47,000	59,000
Airflow Rate	CFM		635	988	1,236
Weight	lbs.		190	271	
Height	in.		18-1/2		
Width	in.		29-1/4	54-3/8	
Depth	in.		43-5/16		
Sound Pressure	dB(A)		42	47	
External Static Pressure	in. Wg		0.88	0.96	1.03
Pipe Connections	Gas	in.	5/8	3/4	7/8
	Liquid	in.	3/8		
Protection Devices			Fuse Fan Motor Thermal Protector		
External Finish			Galvanized Steel Plate		
Operating Range - Cooling	°F		66 DB/59 WB - 109 DB/90 WB		
Operating Range - Heating	°F		23 DB to 59 DB		
Discharge Air Temp. - Cooling	°F		55-77		
Discharge Air Temp. - Heating	°F		64-86		

**Nominal Conditions:**

**Cooling Mode**

Discharge Set Temperature: 64°F DB  
 Outdoor: 91°F DB, 82°F WB (68% RH)  
 Pipe Length: 25 ft.  
 Level Difference: 0 ft.

**Heating Mode**

Discharge Set Temperature: 77°F DB  
 Outdoor: 32°F DB, 27°F WB (50% RH)  
 Pipe Length: 25 ft.  
 Level Difference: 0 ft.

**Note:** Specifications are subject to change without notice.

FXMQ_MFVJU ACCESSORIES			
Model Name	FXMQ48MFVJU	FXMQ72MFVJU	FXMQ96MFVJU
Navigation Remote Controller		BRC1Nrv71/72	
Wireless Remote Controller		BRC4C82	
Madoka Remote Controller		BRC1H71W	
Button Sensor Kit		KRCSH2018-02	
Remote Sensor Kit		KRCS01-1B	
Wiring Adaptor PCB (interface with aux/primary heater, humidifier, OA damper/fan)		KRP1C74	
Group Control Adaptor PCB (connects to external BMS)		KRP4A71	
High Efficiency Filter Kit (MERV 13)	DACA-MQ48F131K		DACA-MQ96F131K
High Efficiency Filter Kit (MERV 8)	DACA-MQ48F-8-1K		DACA-MQ96F-8-1K

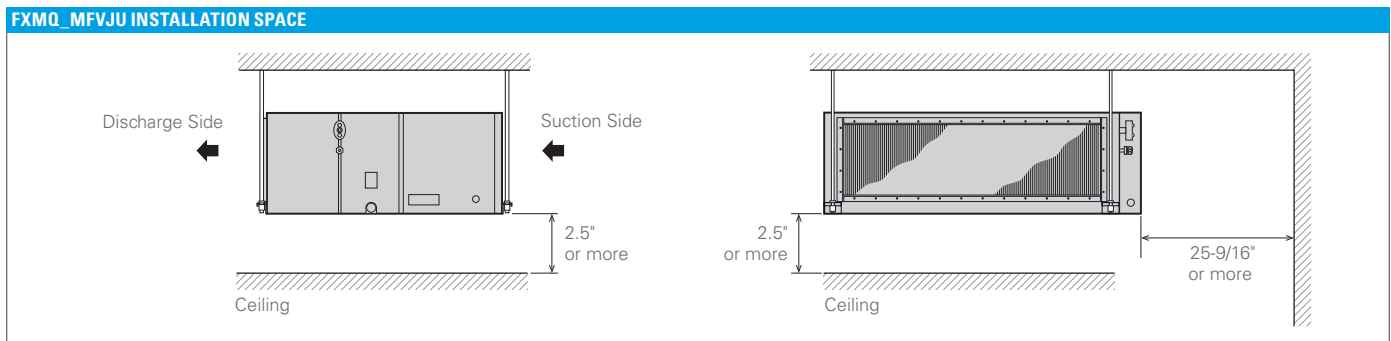

# VAM-GVJU

## Energy Recovery Ventilator



Outside Air  
Integration Possible

### Helping to Improve Indoor Air Quality and Energy Efficiency

The VAM Energy Recovery Ventilator is designed to help improve indoor air quality and reduce the overall HVAC system power consumption. This is achieved by providing fresh outside air and recovering waste heat from exhaust air leaving the conditioned space.

#### Features and Benefits

- » Provides energy-saving heat recovery ventilation via a new heat exchanger with high temperature and enthalpy recovery efficiency
- » Design flexibility thanks to high static pressure fans and the capability for use in a wide range of climates (5°F to 122°F DB and 80% RH or less)\*
- » Wide range of functions such as independent operation, interlock with other HVAC systems, and automatic night purge to reduce cooling loads and increase energy savings
- » Interlocked simultaneous operation with VRV indoor units through a single controller
- » Auto mode switches the ventilation mode (total heat exchange mode to bypass mode) according to the operating status of the air conditioner system
- » Pre-cooling/heating control function to delay the start of ventilation during air conditioner start-up for higher energy savings
- » Supply and exhaust fresh-up operation modes to control pressure within a space
- » Filter sign and display reset notifies when filter changes are required
- » ESP as high as 0.76" W.G.
- » Sound levels as low as 25.5 dB(A) for sound-sensitive installation locations

\* Performance characteristics certified to AHRI Standard 1060 are only applicable to the cooling and heating operating conditions specified in the performance table of this document.

- The cooling effectiveness shall be based on 95°F DB / 78°F WB for the entering supply air and 75°F DB / 63°F WB for the entering exhaust air, at a leaving supply airflow of both 100% and 75% of the rated airflow.
- The heating effectiveness shall be based on 35°F DB / 33°F WB for the entering supply air and 70°F DB / 58°F WB for the entering exhaust air, at a leaving supply airflow of both 100% and 75% of the rated airflow.



BRC1H71W  
(option)



BRC1NRV71/72  
(option)

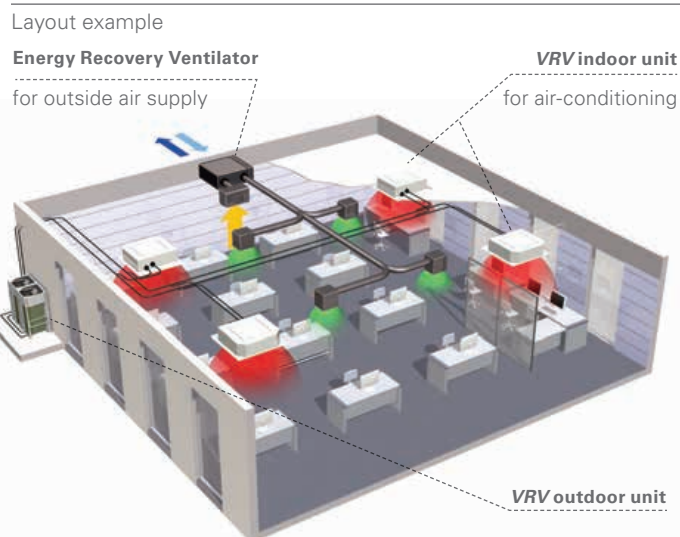

#### Applications

- » Hotel/conference centers
- » Schools
- » Retail shopping centers
- » Large open-plan offices
- » Churches

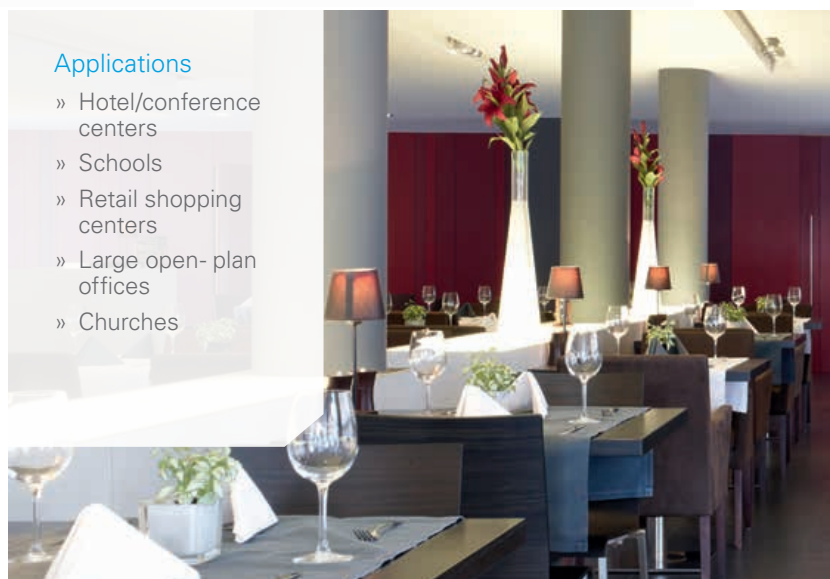

VAM SPECIFICATIONS							
Mode	Airflow	Effectiveness Type		VAM300GVJU	VAM470GVJU	VAM600GVJU	VAM1200GVJU
Heating <sup>1</sup>	100%	Sensible	%	60	62	68	68
		Latent	%	46	48	42	42
	75%	Sensible	%	63	66	72	72
		Latent	%	53	55	47	47
Cooling <sup>1</sup>	100%	Sensible	%	60.6	63	68	68
		Latent	%	29	30	34	34
	75%	Sensible	%	63.9	67	72	72
		Latent	%	40	38	37	37
Power Supply		V/ph/Hz		208-230/1/60			
Airflow Rate (H/M/L)	Heat Exchange Mode	CFM		305/300/170	470/470/390	600/600/500	1,200/1,200/930
	Bypass Mode	CFM		305/300/170	470/470/390	600/600/500	1,200/1,200/930
Weight		lbs.		71	121	148	346
Height		in.		12-1/16	15-1/4	15-1/4	30-7/8
Width		in.		34-5/8	43-11/16		63-3/4
Depth		in.		31-1/2	32-3/4	47-13/16	
Sound Pressure @ 208V (H/M/L)		dB(A)		34.5/31.5/21.5	40/37/33	40.1/37/33.1	43/39/35
External Static Pressure (H/M/L)		in. Wg		0.64/0.26/0.16	0.73/0.39/0.33	0.76/0.34/0.32	0.56/0.24/0.16
External Finish		Galvanized Steel Plate					
Insulation Material		Self-Extinguishing Urethane Foam					
Connection Duct Diameter		in.		8	10		14
Ambient Conditions*		A		5°F ~ 122°F DB 80% RH or less			

\*AHRI 1060 Performance characteristics certified to AHRI Standard 1060 are only applicable to the specified cooling and heating operation conditions, as specified within the performance table in this document.

<sup>1</sup> **Note:** Certified in accordance with the AHRI ERV Certification Program, which is based on AHRI Standard 1060. Certified units may be found in the AHRI Directory at [www.ahridirectory.org](http://www.ahridirectory.org). Performance characteristics certified to AHRI Standard 1060 based on the following conditions:

- » The cooling effectiveness shall be based on 95°F DB / 78°F WB for the entering supply air and 75°F DB / 63°F WB for the entering exhaust air, at a leaving supply airflow of both 100% and 75% of the rated airflow.
- » The heating effectiveness shall be based on 35°F DB / 33°F WB for the entering supply air and 70°F DB / 58°F WB for the entering exhaust air, at a leaving supply airflow of both 100% and 75% of the rated airflow.

#### VAM-GVJU INSTALLATION EXAMPLE

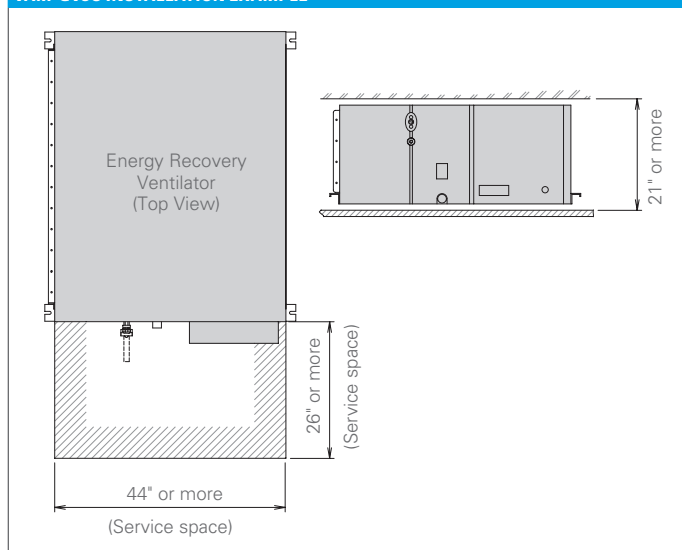

Heat exchanger with high temperature and enthalpy efficiency

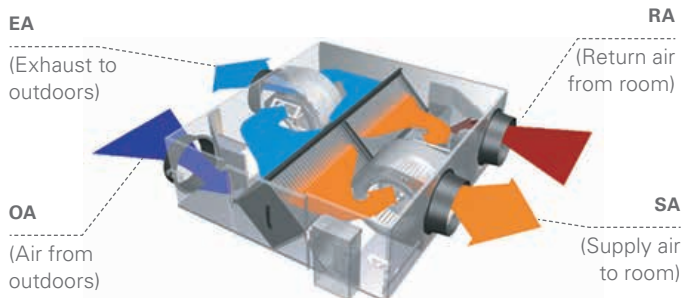

#### ACCESSORIES

Model Name	VAM300GVJU	VAM470GVJU	VAM600GVJU	VAM1200GVJU
Navigation Remote Controller*			BRC1NRV71/72	
Madoka Remote Controller			BRC1H71W	
PCB Adaptor for Humidifier			KRP50-2	

\* Optional face plates available to provide a more intuitive user interface and disable specific functions





# Hot Water Solutions



# Daikin *MEGA-Q*

## All-Electric Hot water Generation System

### Introducing Daikin *MEGA-Q*

Hot water is used in everyday activities. In North America, gas, oil, electric, and steam boilers have been leveraged traditionally to generate hot water. Air-to-water heat pump technology offers an all-electric alternative for generating hot water, reducing dependence on fossil fuel systems. Daikin's inverter-driven Daikin *MEGA-Q* system provides an all-electric hot water solution, making it an ideal choice for commercial buildings with large volume non-potable hot water demand

### Features and Benefits

- » All-electric heat pump technology for non-potable hot water generation in commercial applications.
- » Dependable hot water generation at ambient temperatures from -4°F DB to 109°F DB (from -20°C DB to 43°C DB).
- » Customizable high-leaving water temperatures from 140°F to 194°F (from 60°C to 90°C) with inlet water temperatures from 41°F to 176°F (from 5°C to 80°C).
- » Year-round high efficiencies with up to 4.6+ COP thanks to Daikin's inverter heat pump and cascade technologies.
- » Scalable and modular system design allows for up to 6 Daikin *MEGA-Q* systems to connect to the same hydronic loop, achieving total nominal capacity of 720 MBH.
- » Flexible application design with a vertical separation of up to 65 ft. between the heat source unit and the cascade unit.
- » Modular and compact system design enables installation indoors or outdoors.
- » Built-in variable-speed water pump increases waterside system efficiencies compared to single-speed pumps and can handle water flow rates of up to 3.8 gallons per minute (GPM).

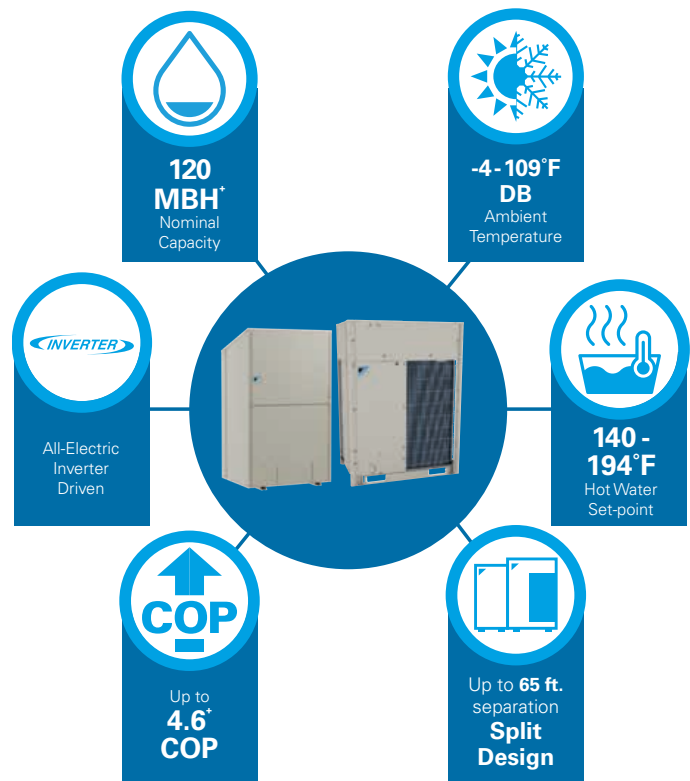

-Based on heating conditions at the outdoor temperature of 77°F DB/69.8°F WB, the outlet water temperature of 149°F, and the inlet water temperature of 75.2°F.



\* Complete warranty details available from your local dealer/contractor or at [www.daikincomfort.com](http://www.daikincomfort.com). Daikin *MEGA-Q* heat source unit (RXHWQ120MQTJA) and cascade unit (BWLP120TJU) come with a 5-Year Parts Limited Warranty where installation and commissioning requirements are satisfied. Other limitations and exclusions apply.

# Daikin *MEGA-Q*

## Efficiency And Flexibility

**Daikin *MEGA-Q* is an all-electric hot water generation system** that is built upon 3 main components—heat source unit, cascade unit, and tank controller kit—providing some attributes of a central hot water generation system but with the flexibility of indoor or outdoor installation.

*MEGA-Q* offers all-electric hot water generation for various non-potable water applications, such as multi-family buildings, offices, hotels, schools, and other large commercial applications.

This innovative system can supply non-potable hot water to commercial buildings even in outdoor ambient temperatures as low as  $-4^{\circ}\text{F}$ . The dual refrigerant circuit split system design features Daikin's Inverter-driven heat pump technology. Coupled with an inverter-driven cascade unit, the *MEGA-Q* supports reliable performance with customizable high-leaving hot water temperatures ranging from  $140^{\circ}\text{F}$  to  $194^{\circ}\text{F}$  with inlet water temperatures from  $41^{\circ}\text{F}$  to  $176^{\circ}\text{F}$ .

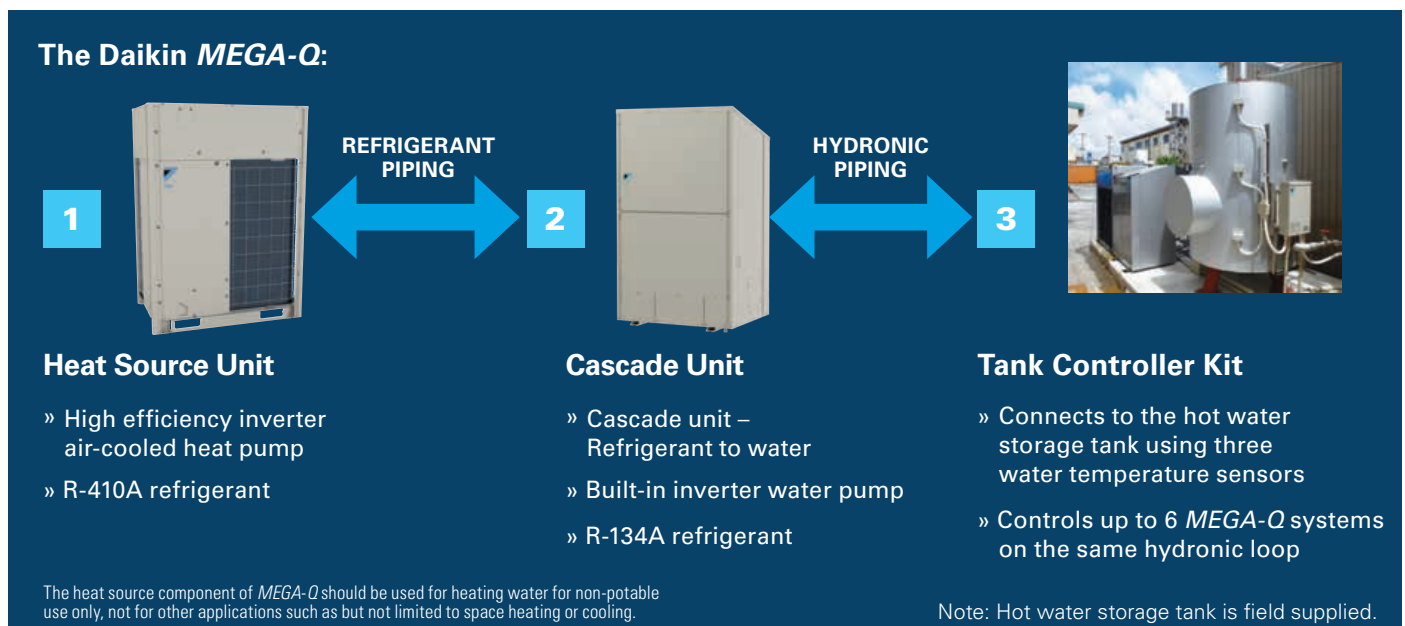

## Flexible Installation



- » The heat source unit and cascade unit are installed outside side by side.

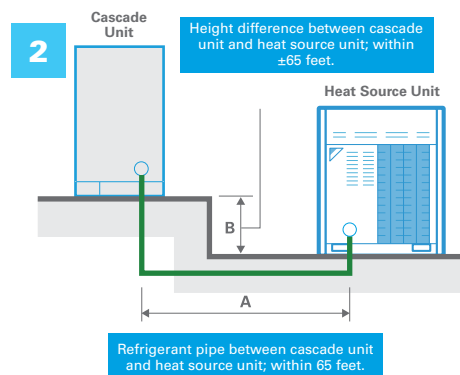

- » The cascade unit can be installed up to 65 feet away from the heat source unit, with the option to place it indoors.

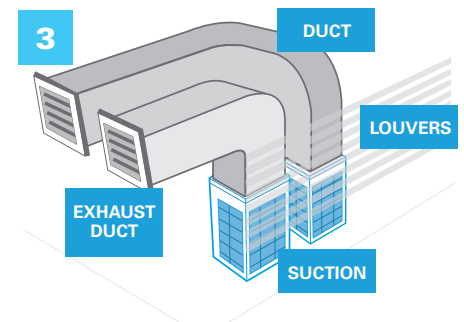

- » Both the heat source unit and cascade unit can be installed indoors. Note that the heat source unit must be ducted to the outside.

# Daikin MEGA-Q

## How it Works

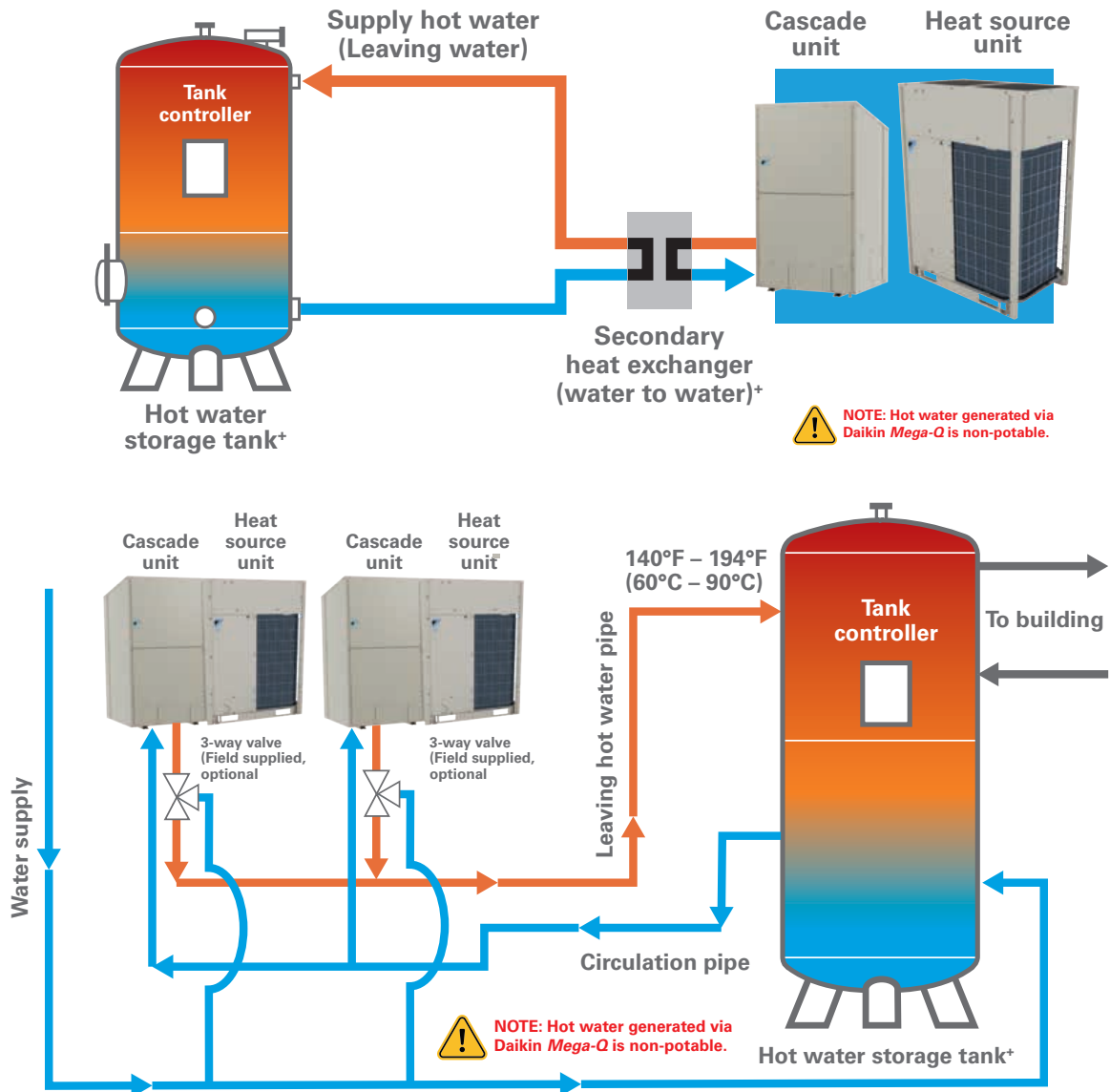

+ Not required for operation of the Daikin MEGA-Q system. Field supplied if used in applications.

Dual refrigerant circuit achieves high-temperature hot water output and high-efficiency operations.

Daikin MEGA-Q takes advantage of the excellent low ambient temperature characteristics of R-410A combined with high temperature boiling characteristics of R-134A to generate high-temperature water up to 194°F.



RXHWQ120MQTJA + BWLP120TJU					
Sound (A scale)		Db	55 (Winter 59)		
Unit Model Name			Heat Source Unit	Cascade Unit	
Model Name			RXHWQ120MQTJ*	BWLP120TJU	
Power Supply	3 Phase 208/230V 60Hz				
Casing Color	Ivory White (5Y7.5/1)				
External Dimensions (H x W x D)	In. (mm)	66-11/16 (1694) x 48-7/8 (1242) x 30-3/16 (767)		60-1/16 (1525) x 35-3/16 (893) x 30 (762)	
Heat Exchanger	Evaporator	Cross Fin Coil		Plate Heat Exchanger	
	Condenser			Winding Spiral Tube Heat Exchanger	
Compressor	Model	Hermetically Sealed Scroll Type			
	Starting System	Soft Start (Inverter)			
	Motor Output	kW	(4.4 + 4.4)	(4.5 + 4.5)	
Fan	Model	Propeller Fan		N/A	
	Motor Output x Number	kW	0.75 x 2	N/A	
	Air Flow	cfm (m <sup>3</sup> /min)	8228 (233)	N/A	
	Drive System	Direct Drive		N/A	
Water Pump	N/A			Non-Self-Priming Canned Pump	
Connecting Pipe	Heat Source Unit	Liquid Side Pipe	in. (mm)	1/2 (12.7) C1220T (Brazen Connection)	N/A
		Gas Side Pipe	in. (mm)	1-1/8 (28.6) (Brazen Connection) *1	N/A
	Heat Source Unit Cascade Unit	Liquid Side Pipe	in. (mm)	1/2 (12.7) C1220T (Brazen Connection)	
		Gas Side Pipe	in. (mm)	7/8 (22.2) C1220T (Brazen Connection) *1	
	Cascade Unit	Liquid Side Pipe	in. (mm)	N/A	1/2 (12.7)
		Gas Side Pipe	in. (mm)	N/A	7/8 (22.2)
		Circulation (water) Pipe	in. (mm)	N/A	NPT3/4 male thread (after the installation of piping adaptor)
		Outlet (hot water) Pipe	in. (mm)	N/A	NPT3/4 male thread (after the installation of piping adaptor)
	Weight	lb. (kg)	695 (315)	639 (290)	
	Safety Device	High pressure switch, Fan driver overload protector, Overcurrent relay, inverter overload protector			High pressure switch, inverter overload protector
	Defrost Method	Deicer			N/A
	Refrigerant	Refrigerant Name	R-410A		High side R-134A Low Side R-410A
		System Charge	lbs. (kg)	18.1 (8.2)	13.2 (6.0)
		Control	Electronic Expansion Valve		
	Design Pressure	High Pressure	PSIG (Mpa)	478 (3.30)	High Side 550 (3.80) Low Side 580 (4.00)
Low Pressure		PSIG (Mpa)	320 (2.21)	High Side 248 (1.71)	

\*1 The pipe diameter on the gas side of the heat source unit is different between the heat source unit and the cascade unit. When arranging piping, procure with the gas piping diameter between the heat source unit and the cascade unit.

UNIT MODEL NAME				TANK CONTROLLER KIT	
<b>Model</b>				<b>BRP26B2VJU</b>	
Controller Box	<b>Power Supply</b>			1-Phase 208/230V 60 Hz	
	Exterior			Ivory White (5Y7.5/1)	
	Dimensions	H x W x D	In. (mm)	17-11/16(450) x 11-13/16(300) x 3-15/16(100)	
	Weight		lbs. (kg)	23 (10.5)	
External Output				Operation ON	
				Malfunction	
External Input				Operation ON	
				Demand Control	
Attached Sensor				Hot Water Set Temperature Switch	
Accessory				Thermistor for hot water (Screw Type) x 3	
				Remote Controller	





What are your choices?

**Zone Controllers**



Navigation Remote Controller (BRC1NRV71/72)  
(Works with both R32 and R-410A)

Wireless Remote Controller

DKN Cloud Wi-Fi Adaptor (AZA16WSCDKA)







Daikin ONE Touch (DTST-TOU-A)

Madoka Remote Controller (BRC1H71W)

Daikin ONE+ Smart Thermostat (DTST-CWBSA-NI-B)

**Multi-Zone Controller**



Daikin HERO Pro Edge (DGE601A71, DGE601B71)

iTM (DCM601B71)

**Interface Solutions**



iTM (DCM601B71)  
+ BACnet Server Gateway Option (DCM014A51)

DKN Plus Interface (AZA16WSPDKC)



Interface for use in BACnet® (DMS502B71)

DIII-Net/Modbus® Adaptor (DTA116A51)



Interface for use in LonWorks® (DMS504C71)

DIII-Net/BACnet MS/TP Communication Adaptor (DTA118A72)

BACnet® is a trademark of ASHRAE.

**External Equipment Control**



iTM (DCM601B71)  
+ BACnet Client Option (DCM009A51)

WAGO® I/O

HERO Pro Edge (DGE601A71, DGE601B71)  
+ BACnet Client Option (DGE009A71/72)

**Adaptors**



Wiring Adaptor (KRP1C74/75/76/77)

External Control Adaptor (DTA104A53)

RA Interface Adaptor (KRP928BB2S)

**Cloud Monitoring**



Daikin HERO Simple Edge (DSE401A71)

Daikin HERO Pro Edge (DGE601A71, DGE601B71)





# VRV Control Systems Overview

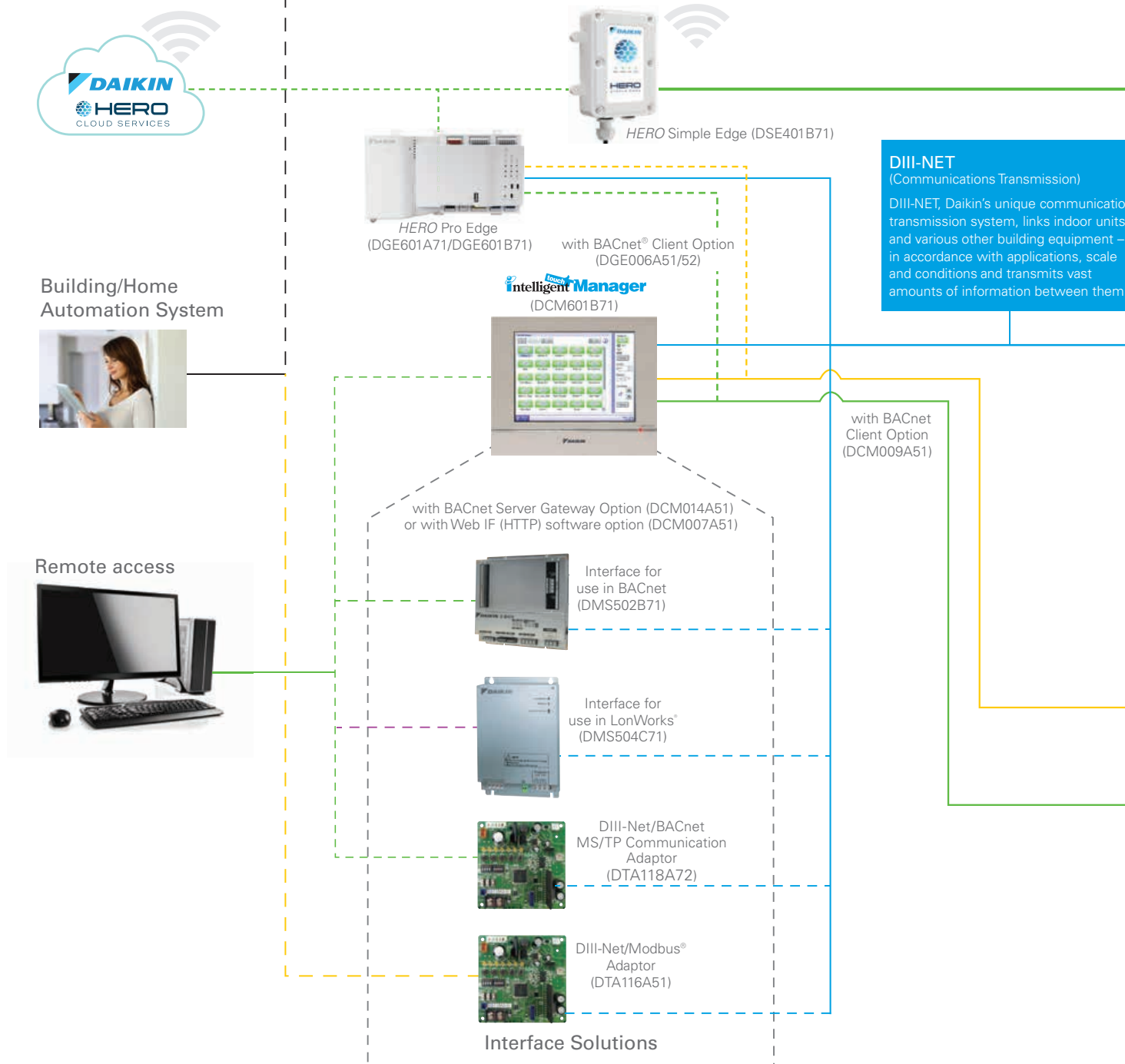

Limitations may apply to some models and functions. Please contact your local sales office for details.

**Note:** BACnet is a registered trademark of the American Society of Heating, Refrigerating and Air-Conditioning Engineers (ASHRAE). LonWorks is a trademark of Echelon Corporation registered in the United States and other countries. Modbus is a registered trademark of Modicon.

BACnet® is a trademark of ASHRAE.

through BACnet® MS/TP, Modbus®, or cloud integration

### Zone Controllers and Integration



DKN Plus Interface

Third-party  
Thermostat



Daikin ONE Touch



DKN Cloud  
Wi-Fi Adaptor



Daikin ONE+  
Smart  
Thermostat



Wireless Remote  
Controller



Madoka Remote  
Controller



Navigation Remote  
Controller (BRC1NRV71/72)  
(Works with both R32 and R-410A)



### External Equipment Control

WAGO I/O



BACnet/IP

#### Building services equipment:

- » Sensors
- » Ventilation Equipment
- » Building Lights
- » Pump
- » Valve



BACnet/IP

MicroTech III



Dedicated Outside Air Supply  
(DOAS)



Light Commercial RTU

BACnet® is a trademark of ASHRAE.



## BRC1NRV71/72 (R410A & R32)

### Navigation Remote Controller

The *Navigation* Remote Controller has been enhanced to meet the configuration requirements of Daikin's *VRV* indoor units. The BRC1NRV71/72 (R410A & R32) provides all the great features and options the market requires. The configurable display and operation buttons will provide as much or as little control as the project requires.

### Features and Benefits

- » Basic Operation
  - On/Off, operation mode, set-point
  - Up to 5 fan speeds selectable (enhanced)
  - Airflow direction (enhanced)
  - Individual louver airflow direction
  - Dual airflow
  - Auto-draft prevention (prevents air blowing directly on occupants)
- » Function
  - Configurable display — Detailed, Standard, and Simple
  - Dual or single cool and heat set-points for occupied periods
  - Independent setback set-points for unoccupied periods
  - Automatic Setback by occupancy sensor
  - Automatic Off by occupancy sensor
  - Unwanted buttons/operation modes can be disabled
  - Set-point range limitation
  - Individual button prohibits/lockout
  - Auto-changeover for Heat Recovery and Heat Pump systems with dual or single set-points
  - Self-cleaning filter panel
  - Automatic adjustment for Daylight Savings Time (DST) (enhanced)
  - Built in 7, 5+2, 5+1+1, and 1 (everyday) schedule with up to 5 actions per day with independent cooling, heating and setback set-points
- » More Features
  - Backlit display
  - Room temperature sensor
  - 12/24 hour clock
  - Fahrenheit/Celsius selectable
  - English/French/Spanish languages selectable



### Auto-changeover

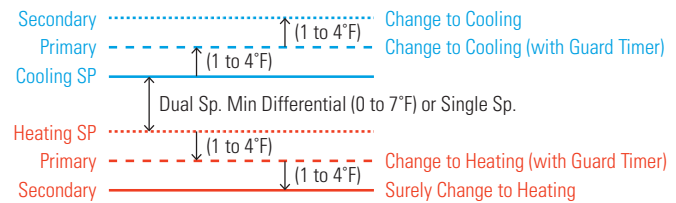

- Remote control group - up to 16 indoor units  
 Automatic changeover is available for Heat Pump system and Heat Recovery systems. The set-point for cooling and heating are configurable with a minimum differential of 0 to 7°F or single set-point. The changeover is automatically controlled to happen in either of the following two cases:

1. **Case 1:** Changeover at the primary changeover temperature after the guard timer expires.
  - In default, the primary changeover set-point is 1°F above cooling set-point or 1°F below heating set-point, which is configurable between 1°F – 4°F.
  - In default, the guard timer is 60 minutes, which is selectable among 15, 30, 60 (default) or 90 minutes.
  - The initiation of guard timer is built in to help prevent frequent changeover which may cause energy loss.
2. **Case 2:** Changeover at the secondary changeover temperature.
  - In default, the secondary changeover temperature is 1°F above the primary changeover temperature for cooling or 1°F below the primary changeover temperature for heating, which is configurable between 1°F – 4°F.
  - Case 2 will happen while the guard time is active in case 1.

## Navigation Remote Controller (continued)

### Configurable Display Mode – Detailed, Standard, Simple

DISPLAY MODE	DETAILED	STANDARD	SIMPLE NEW
Display Image			
On/Off status on LED (LED blinks when an error occurs)	■	■	■
Mode	■ <sup>1</sup>	■ <sup>1</sup>	■ <sup>1</sup>
Set-point (Dual/Single)	■ <sup>2</sup>	■ <sup>2</sup>	■ <sup>2</sup>
Room temperature	■		■
Fan speed	■ <sup>3</sup>	■ <sup>3</sup>	■ <sup>3</sup>
Airflow direction (when a louver is available)	■		
Day and Time	■ <sup>3</sup>		
Status icon	■ <sup>3</sup>	■ <sup>3</sup>	
Key lock icon	■	■	
Error message	■	■	

<sup>1</sup> OFF can be displayed instead of the operation mode while the unit is turned off with the field setting

<sup>2</sup> Can be removed from the display while the unit is turned off with a field setting

<sup>3</sup> Can be removed from the display with a field setting

### On/Off Display Option



### Clear display

- » Backlit display
  - Backlight helps operating in dark rooms.
- » Dot matrix display
  - A combination of fine dots enables various icons.
  - Large text display is easy to see.

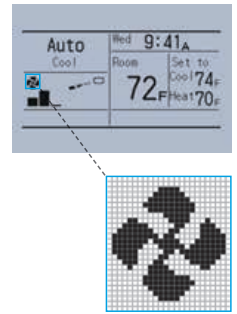

### Simple operation

- » Large buttons and arrow keys
  - Large buttons and arrow keys enable easy operation. Basic setting such as fan speed and temperature can be intuitively operated. For other settings just select the function from the menu list.

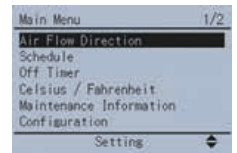

### Optional Face Decals – Hides unnecessary (locked/prohibited) buttons

USED WITH	SINGLE SET-POINT MODE			DUAL SET-POINT MODE		
Model						
	BRC1E72RM	BRC1E72RF	BRC1E72RMF	BRC1E72RM2	BRC1E72RF2	BRC1E72RMF2
On/Off	■	■	■	■	■	■
Mode	■		■	■		■
Fan		■	■		■	■
Up, Down	■	■	■	■	■	■
Left, Right				■	■	■
Menu/Ok						
Cancel						



## Navigation Remote Controller (continued)

### Energy saving

» Automatic Off by occupancy sensor<sup>†</sup>

- The indoor unit will turn off when it is determined that the room is unoccupied after a specified time has elapsed.
- Can be used in conjunction with the Auto Setback by sensor function

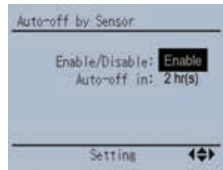

» Auto Setback by sensor<sup>†</sup>

- The cooling and heating set-points will gradually relax (configurable) internally when the room is determined to be unoccupied.
- The internal set-point will return to the original set-point when room occupancy is detected.

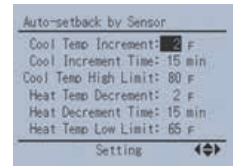

Automatic Off energy savings

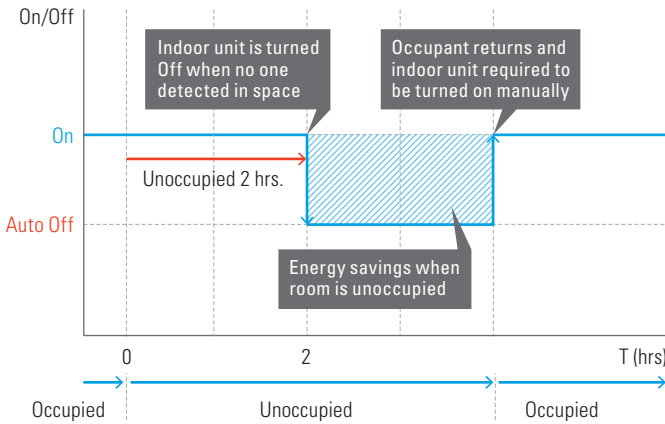

Automatic setback energy savings

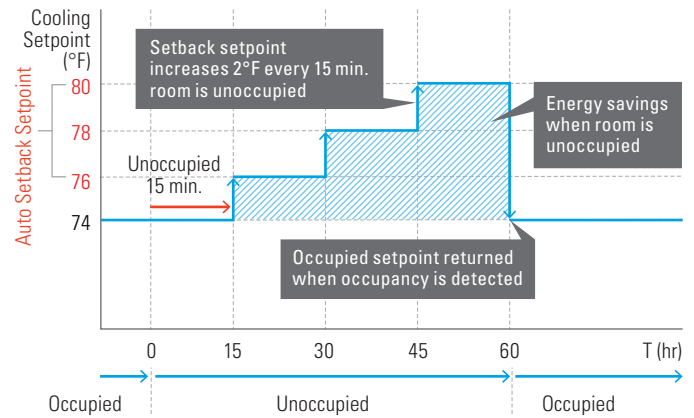

College classroom sample (a summer Monday case)

**1) 8:30 ON**

The first period starts and the air conditioner starts the cooling operation.

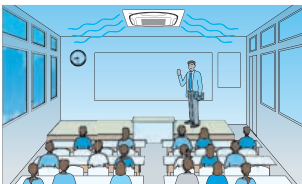

**2) 10:30 OFF**

In the second period, the classroom is unoccupied and the air conditioner stops.

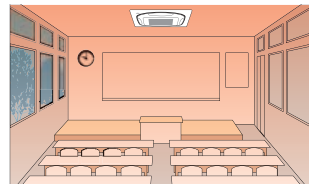

**3) 13:00 ON**

When the third period starts, operation starts again.

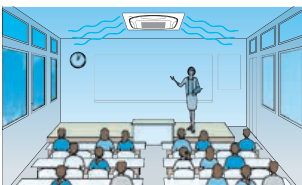

**4) 15:00 OFF**

After the third period, the classroom becomes vacant again and the air conditioner stops.

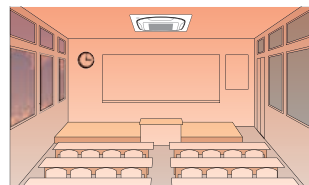



**Comfort**

- » Individual airflow direction†
  - Airflow direction of each of the four air outlets can be controlled individually.
  - (Positions 0 to 4, Swing, and No individual setting are selectable.)
- » Auto airflow rate†
  - Airflow rate is automatically controlled in accordance with the difference between room temperature and set temperature.

† Only available for VRV4-Way Flow Ceiling Suspended type FXUQ\_P series and Ceiling Mounted Cassette (Round Flow with Sensing) type FXFQ\_T series.

Individual airflow direction

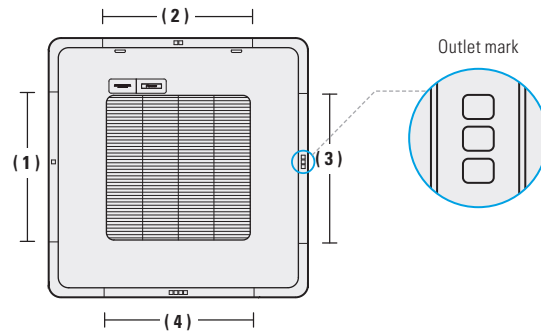

(1)

(2)

(3)

(4)

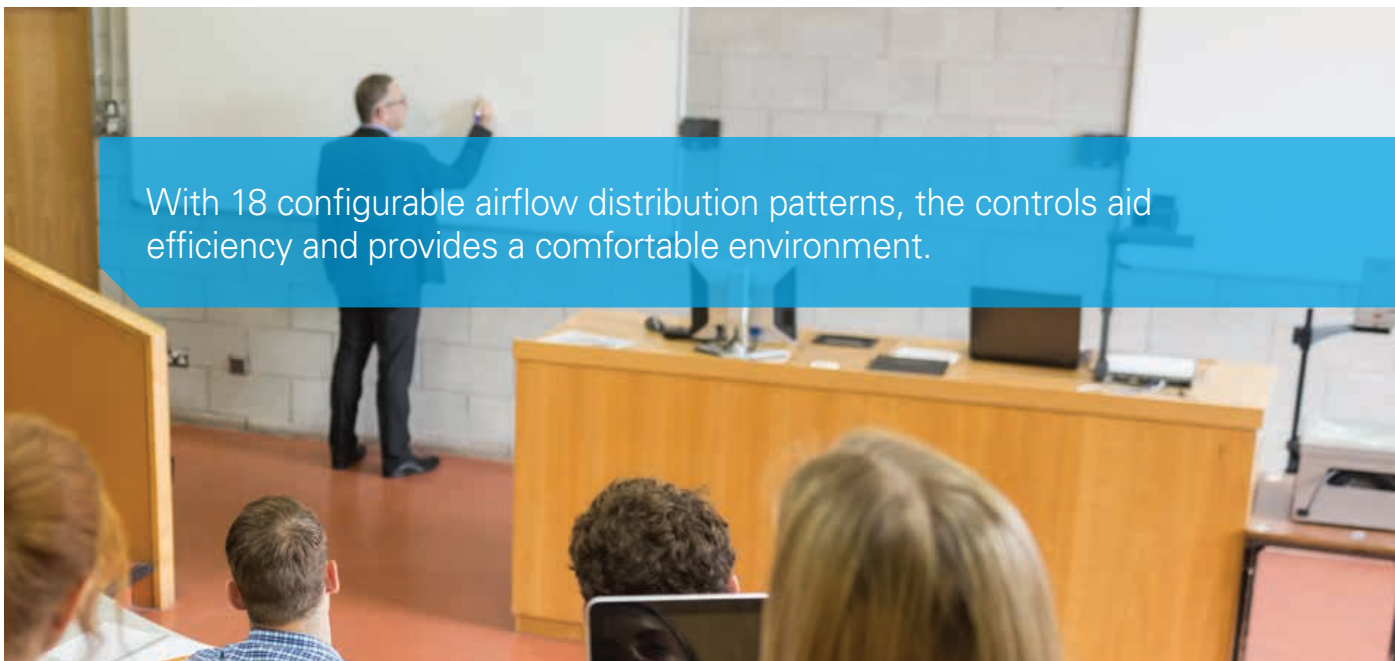

With 18 configurable airflow distribution patterns, the controls aid efficiency and provides a comfortable environment.



## BRC1H71W - Madoka Remote Controller

- » Easy Commissioning
  - Settings and configuration can be copied to and from the app or controller and applied to other controllers using Bluetooth® BLE technology
  - Selective display mode: Text, Icon, and Scale display
  - Field settings are categorized based on the application
  - Language: English, French, Spanish
  - Supports both Fahrenheit and Celsius
- » Basic Control functions
  - On/Off, operation mode, set-point
  - Up to 5 fan speeds selectable
  - Louver direction
  - Auto-draft prevention
- » Advanced functions
  - Setback logic
  - Set-point range limitation
  - Function Prohibition



Madoka Remote Controller

## DTST-CWBSA-NI-B - Daikin ONE+ Smart Thermostat for VRV, SkyAir, Single Zone and Multi-Zone System

- » A cloud-connected smart thermostat to control indoor temperature, humidity, and air quality.
- » Features
  - Capacitive multi-touch display with easy rotational dial and light pipe indication
  - Wi-Fi enabled smart thermostat with smartphone control, voice control and OTA update capability
  - Intelligent energy management with schedule and configurable energy and comfort functions
  - Auxiliary heater control (primary/secondary/emergency heat)

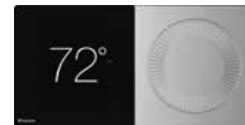

Daikin ONE+ Smart Thermostat

## DTST-TOU-A - Daikin ONE Touch Smart Thermostat

- » Simple, elegant industrial design
- » Capacitive touchscreen user interface
- » Wi-Fi-enabled smart thermostat with iOS and Android app control
- » Voice control by Amazon Alexa and Google Assistant
- » Technical Specifications
  - Capacitive touch screen
  - Backlit, 3.5 inch MVA TFT LCD display
  - Wi-Fi
  - Bi-directional communications protocol for controlling HVAC system



Daikin ONE Touch Thermostat

## AZAI6WSCDKA - DKN Cloud Wi-Fi Adaptor

- » Remote control of VRV indoor units from iOS/Android smartphone app
- » Voice control capability through Google Assistant and Amazon Alexa
- » Provides Cloud API integration option for hotel and home automation integration developers
- » Features
  - On/Off
  - Mode
  - Error alert
  - Leveled user authority
  - Set-point
  - Fan speed
  - Room temperature
  - Louver position



DKN Cloud Wi-Fi Adaptor



### BRC4C82/BRC7E818/BRC7E83/BRC7E830 - Wireless Remote Controller

» The same operation modes and settings as with wired remote controllers are possible.

» Features

- On/Off
- Fan speed adjustment
- Operation mode
- Louver position adjustment
- Single set-point
- Reports system malfunctions

» A compact signal receiver unit (separate type) to be mounted into a wall or ceiling is included.

- The Ceiling Suspended and Wall-Mount indoor units use signal receivers that are mounted in the indoor unit.

\* Wireless remote controller and signal receiver unit are sold as a set.



Wireless remote controller\*



Signal receiver unit (separate type)\*

INDIVIDUAL CONTROL CAPABILITIES						
	DKN Cloud Wi-Fi Adaptor (AZAI6WSCDKA)	Navigation Remote Controller (BRC1NRV1/72) R32 (R410A)	Daikin ONE+ Smart Thermostat (DTST-CWBSA-NI-B) R32	Daikin ONE Touch DTST-TOU-A R32	Wireless Remote Controller (model depends on unit)	Madoka Remote Controller (BRC1H71W)
Communications	2 Wire / P1P2	2 Wire / P1P2	2 Wire / P1P2	2 Wire / P1P2	Infrared	2 Wire / P1P2
°F/°C Selector	●	●	●	●	°F only	●
Display		Backlight LCD Display	Multi-touch capacitive color display	Multi-touch capacitive color display		Backlight LCD Display
Room temperature display	●	●	●	●		●
Schedule and setback capabilities (with Time and Date display)	●	●	●	●		
User restriction options		●				●
On/Off, Operation mode, Set-point, Fan speed	●	●	●	●	●	●
Louver position adjustment	●	●	●	●	●	●
Reports system malfunctions	●	●	●	●	●	●
Space temperature sensor	●	●	●	●		●
Simultaneous operation with Daikin multi-zone controllers	●	●	Monitor only	Monitor only	●	●
Simultaneous operation with BACnet® and LonWorks®	●	●	Monitor only	Monitor only	●	●
Group control capacity	Up to 16 indoor units*	Up to 16 indoor units			Up to 16 indoor units	Up to 16 indoor units

\* with future software update BACnet® is a trademark of ASHRAE.

### Summary

REMOTE CONTROLLER COMPATIBILITY WITH VRV INDOOR UNITS											
	FXFQ_TA	FXZQ	FXUQ	FXDQ	FXSQ	FXMQ	FXHQ	FXAQ	FXL(N)Q	FXTQ	FXEQ
Navigation remote controller (Wired remote controller)	■	■	■	■	■	■	■	■	■	■	■
Madoka Remote Controller	■	■	■	■	■	■	■	■	■	■	■
Wireless remote controller (Installed type signal receiver unit)		■					■	■			
Wireless remote controller (Separate type signal receiver unit)				■	■	■			■		
DKN Cloud Wi-Fi Adaptor	■	■	■	■	■	■	■	■	■	■	■

### Summary

REMOTE CONTROLLER COMPATIBILITY WITH VRV INDOOR UNITS				
	FXFA	FXTA	FXMA	FXSA
Navigation remote controller (Wired remote controller) – (R-32)	■	■	■	■

# Advanced Multi-Zone Controllers – Daikin *HERO* Pro Edge



The Daikin *HERO* Pro Edge is a cloud-based VRV central controller that offers real-time remote control and monitoring, advanced analytics, and dashboard. The Daikin *HERO* Pro Edge can monitor and control multi-split, Daikin Rooftop Unit (RTU), Dedicated Outside Air Unit (DOAS) and non-Daikin systems. Daikin *HERO* Cloud Services is based upon a recurring license fee to access site information. The Daikin *HERO* Pro Edge includes first-year access to Daikin *HERO* Cloud Services for monitoring and control, licenses can be renewed in 1-year, 3-year or 5-year increments.

## Easy Operation

- » Remote monitoring for Daikin VRV outdoor and indoor unit operation data across multiple sites
- » Accessible any time and from anywhere through the Daikin *HERO* Cloud Services web page or app
- » Intuitive, customizable dashboard provides quick status of connected units and sites
- » Animated piping diagram based on system mode of operation

## Advanced Control Logic

- » Independent cool and heat set-points or single set point in the occupied period
- » Independent setback set-points in the unoccupied period
- » Weekly schedule with timed override
- » Auto changeover with configurable methods

## Operational Data

- » Operation data are stored in the Daikin *HERO* Cloud Service in 1 minute intervals and stored for 5 years with the Daikin *HERO* Pro Edge activation.
  - Indoor unit and outdoor unit operation data
  - BACnet® Client objects
  - WAGO® I/O system data
- » Operation data can be viewed in the Daikin *HERO* Cloud Services or downloaded as CSV files

## Mini BMS Solution with Software and Hardware Options

- » Auto changeover, interlock, schedule and emergency stop for facility management.
- » DI, DO, AI, AO points integrated via the WAGO® I/O System
- » BACnet points (AI, AO, AV, BI, BO, BV, MSI, MSO, MSV) integrated with the Daikin *HERO* Pro Edge BACnet Client Option

## Facility Management and Billing

- » Remote web or app access
- » Continuous commissioning by remotely adjusting the outdoor unit field settings
- » Tenant billing with the Daikin *HERO* Pro Edge PPD option
- » Demand control capabilities to set set-point shift, control thermo-on/off or outdoor unit capacity based upon schedule setting

## Prediction logic and Notifications

- » Utilizes predictive algorithms to alert users of potential failures
- » Prediction alerts can be accessed on the Daikin *HERO* Cloud Services dashboard and are also distributed through email

BACnet® is a trademark of ASHRAE.



**HERO**  
CLOUD SERVICES

Internet

BACnet® / IP



DOAS and other  
third-party system



Remote  
monitoring



Fan

3 DO



kWh meter

8 Di



RS485



WAGO I/O



Lighting



Fan



Pump



Sensor



BACnet® is a trademark of ASHRAE.

# Advanced Multi-Zone Controllers – Daikin HERO Pro Edge (cont.)



- » The Daikin HERO Cloud Service enables remote management for the Daikin VRV system with other general equipment integrated into the Daikin HERO Pro Edge so they can be accessed from the daikinhero.com or the Daikin HERO Cloud Services App.
- » The Daikin HERO Cloud Service is a powerful remote service tool where the Daikin VRV operation data is stored in the cloud for the last 5 years can be downloaded through the web function. Trend graphs of the system operation can be created allowing the service technicians to analyze and diagnose the system without visiting the job site. This feature will provide

the service technician with a view into the Daikin VRV system operation and performance prior to or after an abnormal issue has occurred.

- » Automatic Alert/Error e-mail enables prompt response by service personnel based on timely and precise knowledge of what happened in the system at the remote site.
- » Access to data prior to and after alarm generation as the error marker with time stamp indicates when the error occurred. Also, the trend charts has the ability to trend up to 40 data points at a time for easy diagnostics.

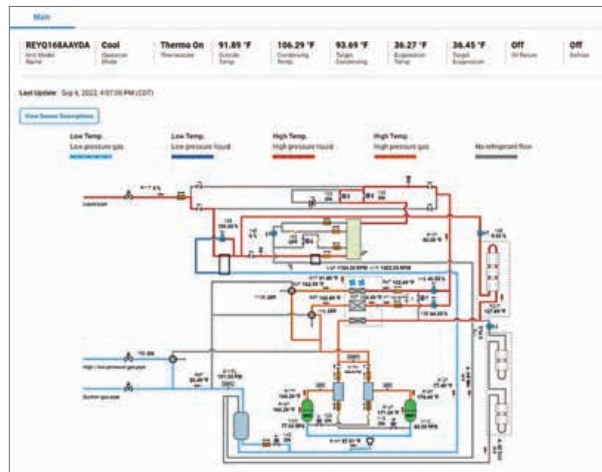



### Tenant Billing (PPD Option)

The PPD (Power Proportional Distribution) option records all the operation duration, room temperature, electronic expansion valve opening ratio data, etc. Based on the recorded data, the energy consumption of the Daikin VRV system is proportionally calculated for each indoor unit. The calculated data can be used for tenant billing.

### Features

- » PPD data can be downloaded using the Daikin HERO Cloud Service
- » Automated Tenant reporting with smart notification to the facility manager
- » Configure output of the Tenant Reports
  - Allows for company logo and info to be added.
  - Selectable start and end period
  - Provide cost per kWh, admin fees and determine if heating usages should be excluded from billing.
  - Separated cooling and heating energy calculation.
  - Select the type of file output.
- » Send the tenant report by email.

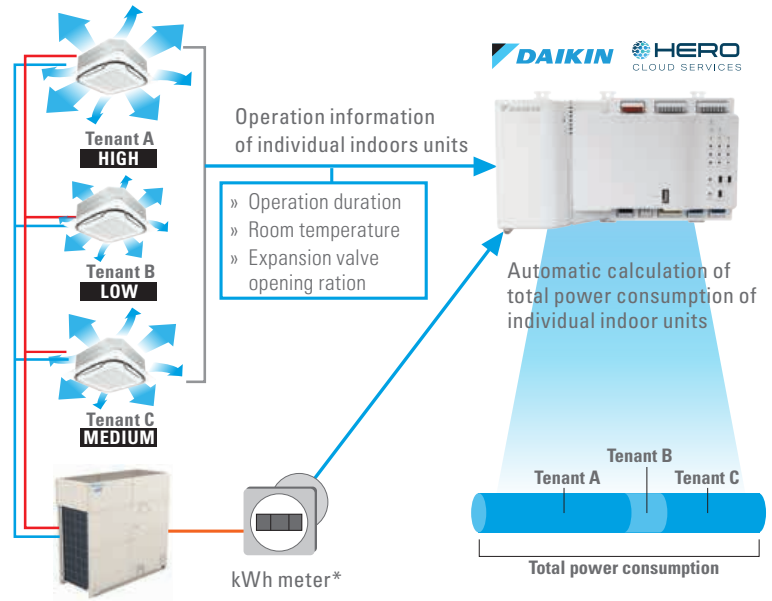

\* Pulse power meter that provides an output of 1 pulse per 1 kw and has a width of 40-400 milliseconds.

**Set Up Monthly Site and Tenant Reports**

Site logo

Choose the monthly period for your Site and Tenant Reports.

Parameters to include:  
 kWh  \$ Cost

% ODU Consumption  % Meter

It is possible to include up to six time slots with corresponding hourly energy consumption costs.  
  \$ /kWh

Export format:  
 Site Report  PDF  CSV  
 Tenant Report  PDF  CSV

Send report to:  
 Report Receiver:   
 Report Receiver:   
 Report Receiver:   
 Report Receiver:

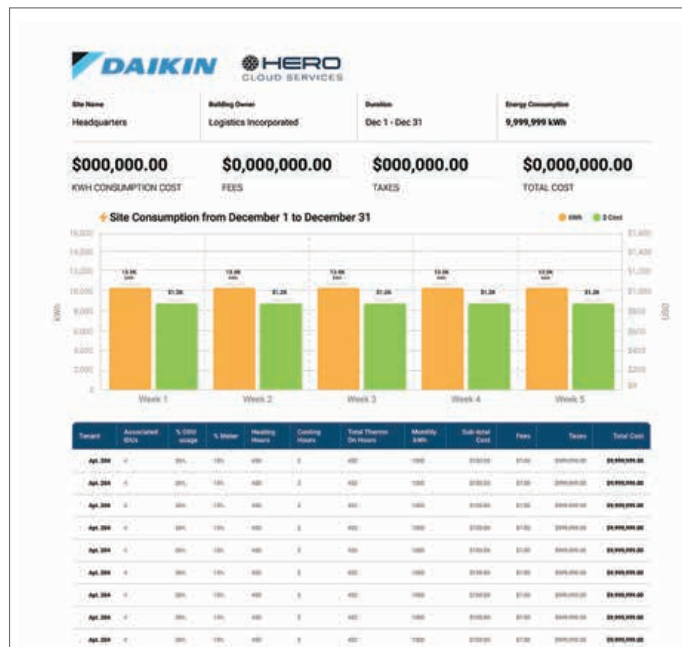

# Advanced Multi-Zone Controllers – Daikin *HERO* Pro Edge (cont.)



## BACnet® Client Option

The Daikin *HERO* Pro Edge offers an advanced and cost-effective solution for Building Management Systems (BMS) applications. The BACnet Client Option provides more flexibility to enhance the Daikin *HERO* Pro Edge's function as a mini BMS. With this option, the Daikin *HERO* Pro Edge is able to manage third party DOAS and other third party equipment through the BACnet / IP protocol. By registering equipment connected to a BACnet server as management points in the Daikin *HERO* Pro Edge, you can now monitor and control the equipment from the Daikin *HERO* Cloud Service.

## Features and Benefits:

- » Cost-effective BMS solution
- » Direct connection on Daikin *HERO* Pro Edge using the BACnet/IP Protocol
- » Integrated control on Daikin *VRV* system and Daikin Applied System
- » Monitors and controls third party equipment
- » Daikin Light Commercial rooftop units (RTU) with *iLINQ* controller. Monitor and control Daikin Light Commercial rooftop units (RTU) with *iLINQ* controller.

**BACnet Client DGE009A71 can manage up to 10 BACnet devices; while the BACnet Client DGE009A72 can manage up to 50 BACnet devices.**

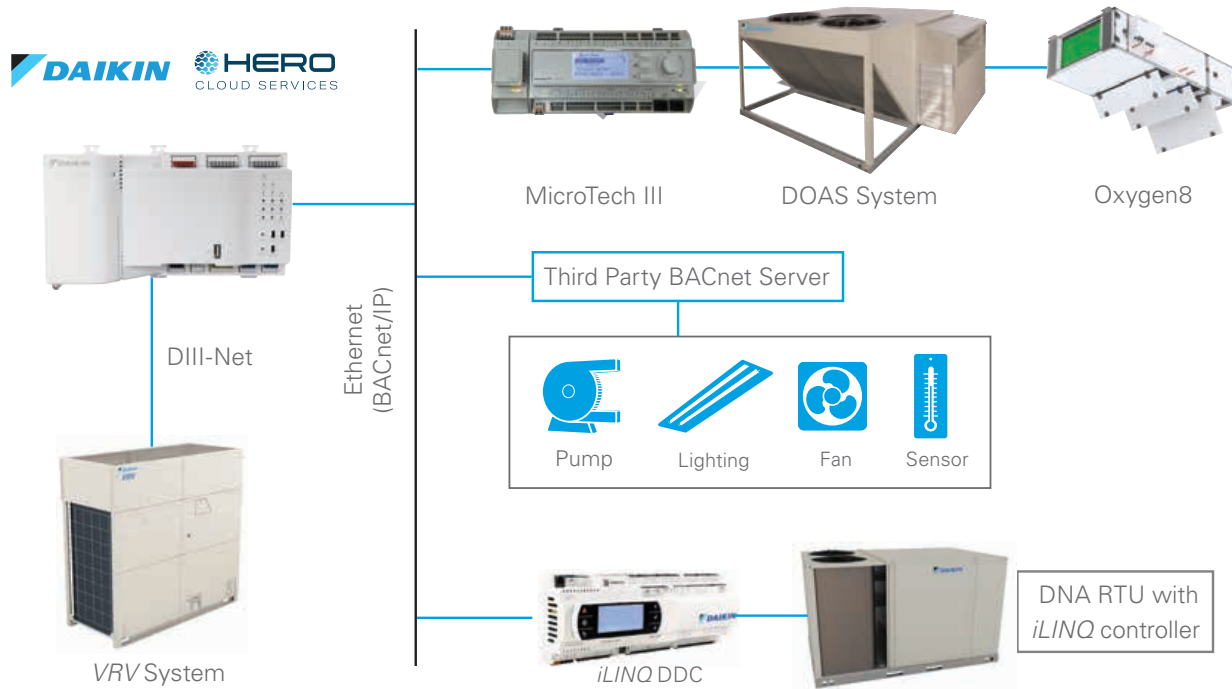

## Object Types

- » Analog Input, Analog Output, Analog Value
- » Binary Input, Binary Output, Binary Value
- » Multi-State Input, Multi-State Output, Multi-State Value

## Applications

- » Sensors, Pumps, Lights, Fans
- » AHU, Alarms, DOAS, Elevator

BACnet® is a trademark of ASHRAE.

## DCM601B71 - intelligent Touch Manager (iTM)

The *intelligent Touch Manager (iTM)* is an advanced multi-zone controller that provides the most cost-effective way to control and monitor the Daikin VRV system.

### Centralized and Advanced VRV Control

Up to 64 Indoor Unit Groups (128 actual Indoor Units) can be monitored and controlled with individual Cool and Heat Set-points, Set-point Range Limitation, Setback Set-points, and Auto changeover to meet your expectations and project requirements. Up to 512 Indoor Unit Groups (1024 actual Indoor Units) can be monitored and controlled with the addition of up to 7 optional *iTM* Plus Adaptors (DCM601A72).

### Built-in Service Tool with Remote Access

- » Operation data are stored in the *iTM* for the last 5 days:
  - Indoor unit and outdoor unit operation data
  - BACnet® Client objects
  - WAGO® I/O system data
- » Operation data can be exported through a USB drive or through the *iTM* web browser remotely
- » BMS can monitor the BACnet objects of indoor unit and outdoor unit operation data with the BACnet Server Gateway Option activated

### Ancillary Equipment Control

Integrates and/or interlocks sensors, switches, dampers, fans, pumps, and lighting with Daikin indoor units.

### Web Access and Alert E-mail

Allows daily remote monitoring and control with the Web/E-mail function that can be accessed via the facility's Local Area Network or your Internet connection. Sends Error E-mail to mobile devices with the Web/E-mail function.

### Tenant Billing

Determines energy consumption of shared condensing units based upon tenant (Indoor Unit) demand using the PPD Software option (DCM002A71).

### Features

- » 10.4" LCD touch screen, USB drive
- » Advanced, scalable and cost-effective management system
  - Up to 650 points (max 512 indoor unit groups (1024 indoor units))
  - Floor plan layout view

### Functions

- » Dual set-points or Single set-point in occupied or Setback in unoccupied
- » Set-point Range Limitation
- » Scheduling (7 day, Weekday-Weekend, Weekday-Saturday-Sunday, Everyday)



**Intelligent Manager**

- » Scheduling (7 day, Weekday-Weekend, Weekday-Saturday-Sunday, Everyday)
- » Optimum Start and Timed Override
- » Advanced Auto changeover
  - Applicable to both VRV Heat Pump and Heat Recovery systems
  - Fixed, Individual, Average and Vote methods
- » Demand Response
  - Interlock the digital input signals to provide automatic demand control functions
  - Multiple demand control functions: Indoor unit set-point shift control, Indoor unit forced thermo-off, Indoor unit on/off control and outdoor unit's capacity demand limit control
- » WAGO I/O
  - Monitor and control 3rd party equipment with DI, DO, AI and AO signals
  - Up to 512 management points
  - Interlock function with indoor units and ancillary equipment
- » Power Proportional Distribution Option (DCM002A71)
  - Calculates apportionment of outdoor unit's total power consumption to individual units on the system
- » *iTM* BACnet Client Option (DCM009A51)
  - Enabling the BACnet Client option allows the *iTM* to use the BACnet/IP protocol
  - Allows for full monitoring and control of 3rd party BACnet capable equipment
  - Up to 512 BACnet management points
- » *iTM* BACnet Server Gateway Option (DCM014A51)
  - Enable BMS to control indoor units and/or monitor outdoor unit operation via BACnet/IP (up to a total of 128 BACnet device IDs and 4000 BACnet objects)
  - Virtual router function embedded that enables individual and configurable BACnet device ID for each indoor unit group address and each outdoor unit.
- » Web (HTTP) Interface Option (DCM007A51)
  - The *iTM* Web IF (HTTP) software provides a building automation system or a home automation system the ability to monitor and control the VRV indoor units over the HTTP protocol

BACnet® is a trademark of ASHRAE.

# Advanced Multi-Zone Controllers – Intelligent Touch Manager (iTM) (cont.)



## iTM System Overview

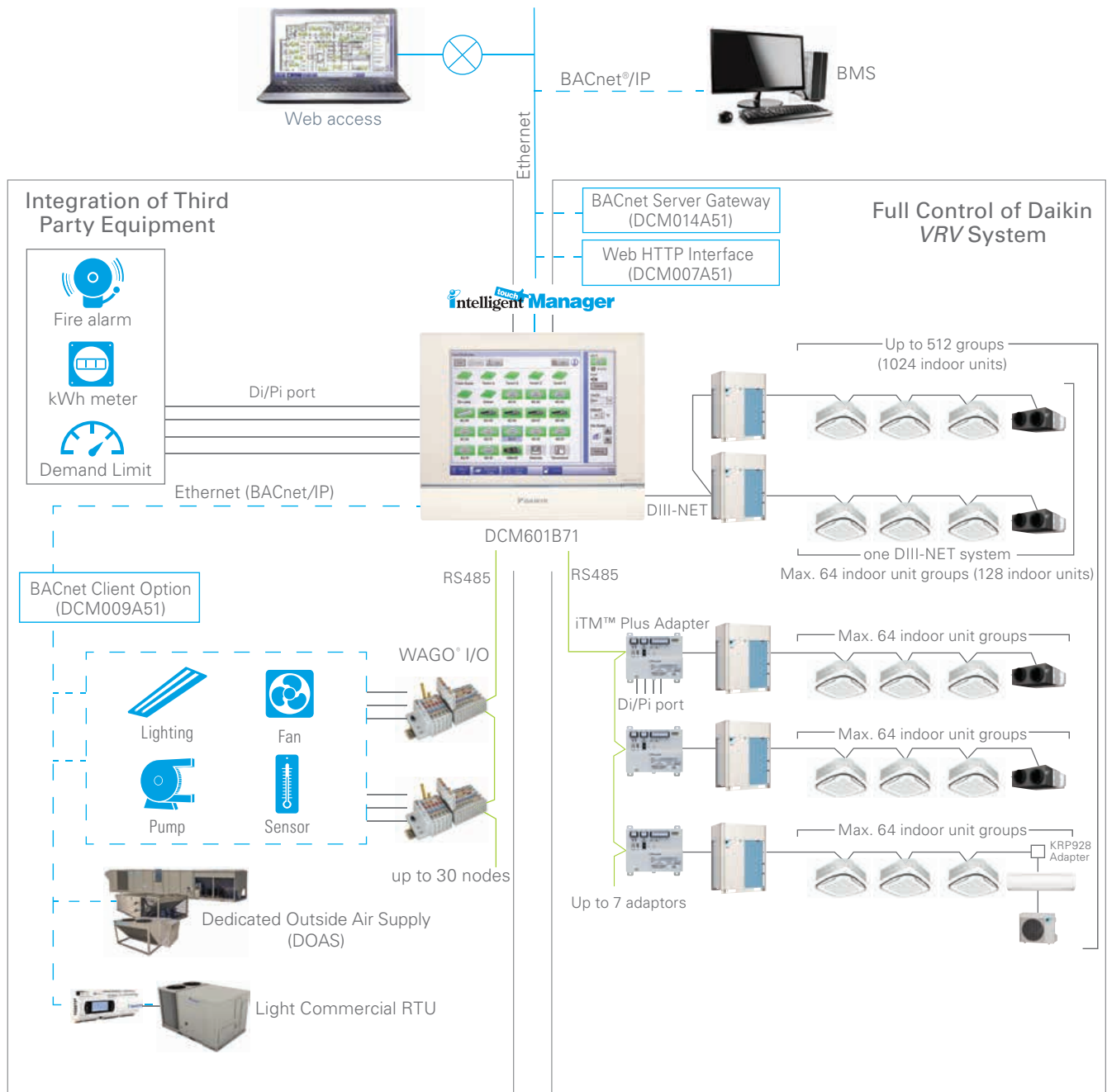

BACnet® is a trademark of ASHRAE.



### DCM009A51 - *iTM* BACnet® Client Option

The *intelligent Touch Manager (iTM)* offers an advanced and cost-effective solution for Building Management Systems (BMS) applications. The *iTM* BACnet Client Option (DCM009A51) provides more flexibility to enhance the *iTM*'s function as a mini BMS. With this option, the *iTM* is able to manage DOAS systems and other third party equipment through the BACnet/IP protocol. By registering equipment connected to a BACnet server as management points in the *iTM*, you can now monitor and control the equipment via the *iTM*.

### Features

- » Cost-effective BMS solution
- » Direct connection on *iTM* using the BACnet/IP Protocol
- » Integrated control on Daikin VRV system and Daikin Applied System
- » Monitors and controls third party equipment
- » Easy commissioning with pre-engineering Preset Tool
- » Easy monitoring with preconfigured GUI

### Intelligent Touch Manager with BACnet Client Option

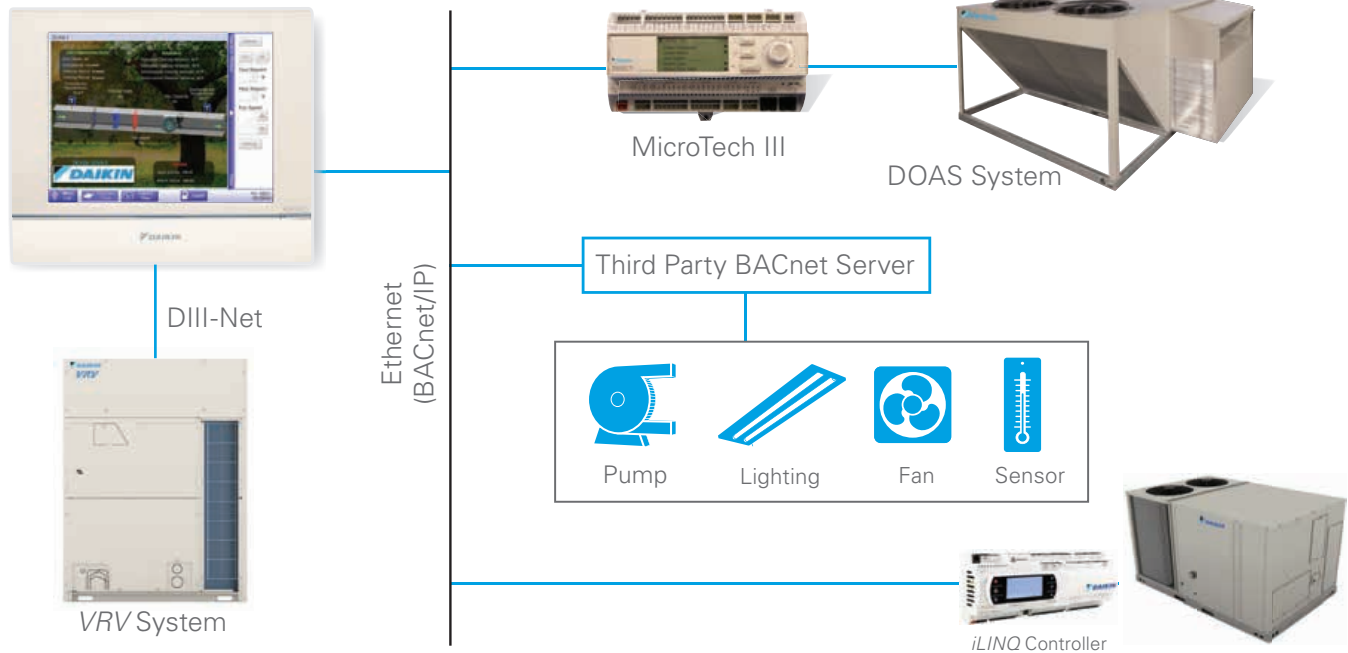

### Object Types

- » Analog Input, Analog Output, Analog Value
- » Binary Input, Binary Output, Binary Value
- » Multi-State Input, Multi-State Output, Multi-State Value

BACnet® is a trademark of ASHRAE.

### Applications

- » Simple I/O: Sensor, Pump, Light, Fan
- » Multi-State Objects: AHU, Alarm, Elevator



## DKN Plus Interface

The DKN Plus Interface (AZAI6WSPDKC) enables the energy-efficient control of Daikin air conditioners by a third-party thermostat or an automation system. With this interface, third-party devices or systems can control the VRV, SkyAir, and Daikin Single/Multi-Zone indoor units through Cloud API, Modbus®, BACnet® MS/TP, or thermostat relay contacts. This interface can be commissioned with ease through the DKN Cloud North America (NA) app via Bluetooth® Low Energy (BLE).



## Features

» Versatile interface adaptor that can integrate with a third-party thermostat/BMS through multiple approaches:

- Cloud API
- Modbus
- BACnet MS/TP
- Backup thermostat G/Y/W (Fan/Cool/Heat) relay control through thermostat wire:
  - Automatically disables thermostat relay logic when cloud API connection detected
  - Advanced control logic to maximize indoor unit efficiency

» Easy commissioning with the BLE configuration app (DKN Cloud NA app)

» Indoor unit control and monitoring points\*

- On/Off
  - Set-point
  - Room temperature
  - Mode (Auto, Cool, Heat, Fan, Dry)
  - Fan speed
  - Louver position
  - Error code
  - Interlock control with indoor unit On/Off
- » Auxiliary Heater Control
- Auxiliary heater controlled as a secondary heat source

\*Availability depends on indoor unit model

## Integration with Building Management System (BMS) or Home Automation System (HAS)

» Integration through Modbus or BACnet MS/TP

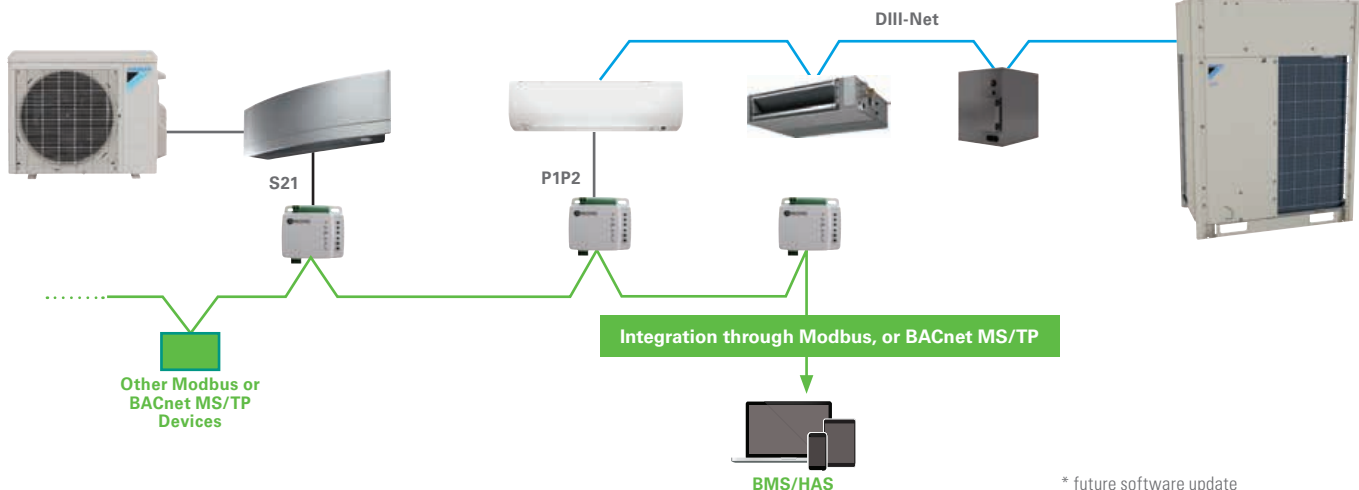

\* future software update

BACnet® is a trademark of ASHRAE.

## System Diagram

### Integration with 3rd party thermostat

» The adaptor provides 4 different approaches for a 3rd party thermostat to control the Daikin indoor units

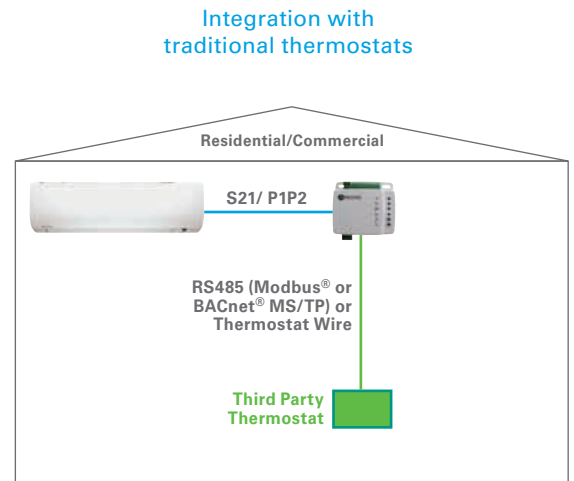
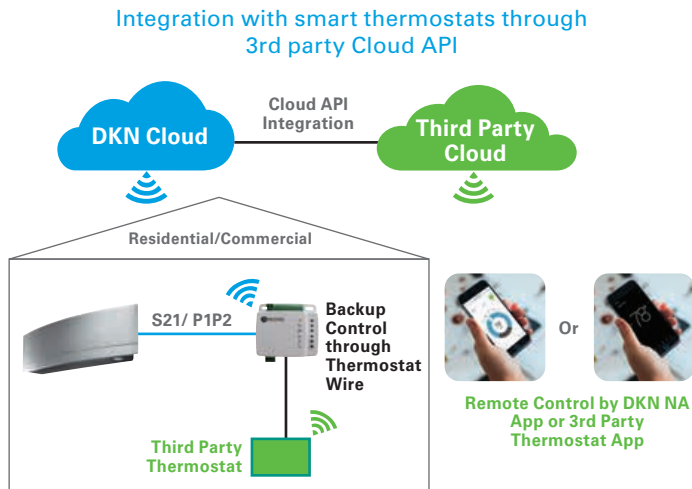

BACnet® is a trademark of ASHRAE.

» Integration through Cloud API

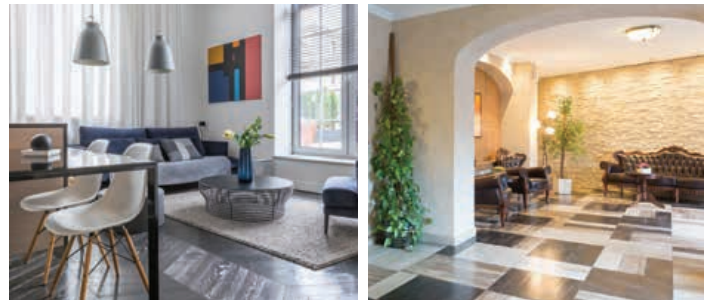
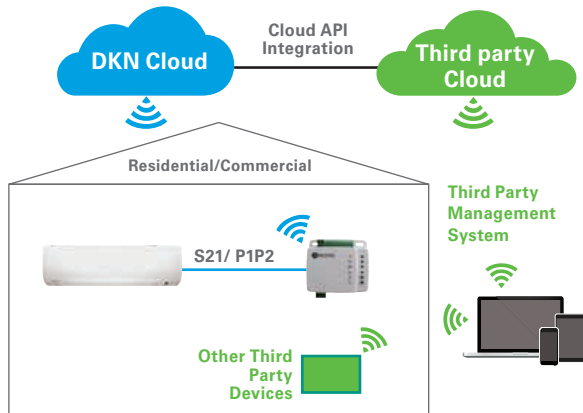

Modbus is a registered trademark of Schneider Electric USA, Inc.

BACnet® is a trademark of ASHRAE.

The Bluetooth® word mark and logos are registered trademarks owned by Bluetooth SIG, Inc., and any use of such marks are under license.

## DCM014A51 - *iTM* BACnet® Server Gateway Option

The *intelligent Touch Manager (iTM)* is capable of serving as a BACnet interface for Building Management System (BMS) integration. With the *iTM* BACnet Server Gateway Option (DCM014A51), the *iTM* provides BMS integrators with the ability to monitor and/or control the VRV indoor and outdoor units, eliminating the need for an additional hardware interface. Moreover, with the latest software update to the *iTM* 2+ (v2.06), the *iTM* is able to serve as a service tool to access indoor and outdoor unit operation data. With the *iTM* BACnet Server Gateway Option, the operation data points for both the IDU (indoor unit) and ODU (outdoor unit) are also available to the BMS through BACnet.

### Features

- » Additional service data points are now available\*:
  - 6 new IDU service data points
  - 9 new common ODU service data points and 22 new service data points for each ODU module
- » Direct connection on *iTM* using the BACnet/IP Protocol
- » Supports Change of Value (COV) notifications to the BMS

- » Configurable as a BACnet foreign device if a BBMD exist on a different subnet within a BACnet network
- » **BACnet virtual router** function implemented:
  - **Individual BACnet device ID** assigned to each indoor unit group address and each outdoor unit
  - Indoor unit group names created in the *iTM* are visible on the BMS
- » Easy commissioning using CSV file
  - Available objects can be configured for each indoor unit
- » **Independent heating and cooling set-points** for occupied and unoccupied periods
- » Individual min/max **Set-point Range Limitation** for heat and cool modes
- » The *iTM*'s **auto changeover, set-point range limitation, setback, dual set-point** logic and **schedule** can be accessed by the BMS
- » Up to 128 Device IDs (including both indoor units and outdoor units) and up to 4000 BACnet objects can be monitored and controlled by BMS.
  - When the IDU/ODU operation data is enabled a total of 128 devices and 4000 BACnet points are available
- » Up to 7 *iTM* Plus Adaptors can be connected to an *iTM* for a total of 8 DIII-Net ports

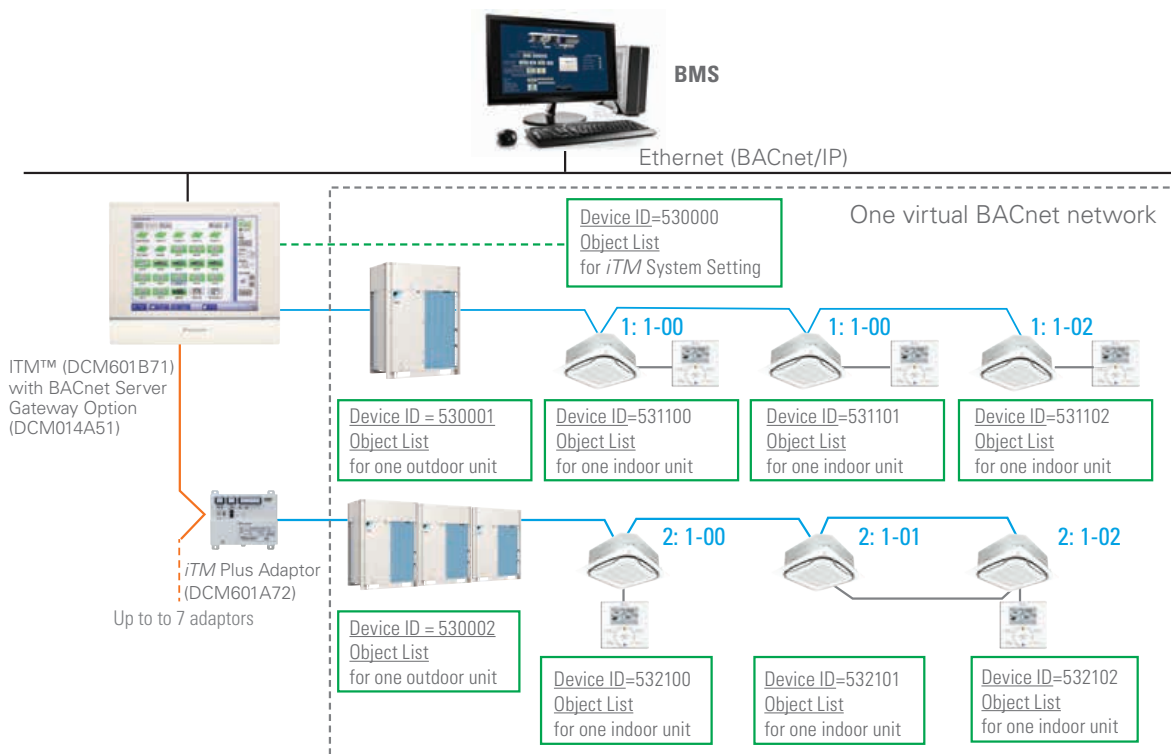

BACnet® is a trademark of ASHRAE.

## Powerful Service Tool with Indoor and Outdoor Unit Operation Data Points



- » When a problem occurs, the BMS integrators and Service Technicians can start troubleshooting remotely immediately before going to the site.
  - » Indoor and outdoor operation data trending\* by Third party BMS can benefit the VRV service process.
- \*BMS programming needed

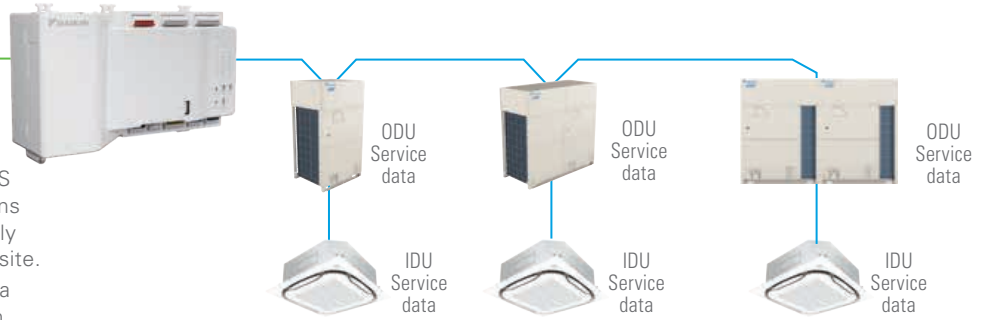

## Enhanced BMS Integration Solution for Indoor Unit Operation



**Individual Device instance number for each indoor unit (Configurable)**

Device ID (1:1-00) = 531100    Device ID (1:1-01) = 531101

**Object instance number repeated for every indoor unit point**

Occupancy Mode = MO 1 (All indoor units)  
Unit On Off Status = BI 2 (All indoor units)

### Advanced iTM BACnet® Server Gateway Points

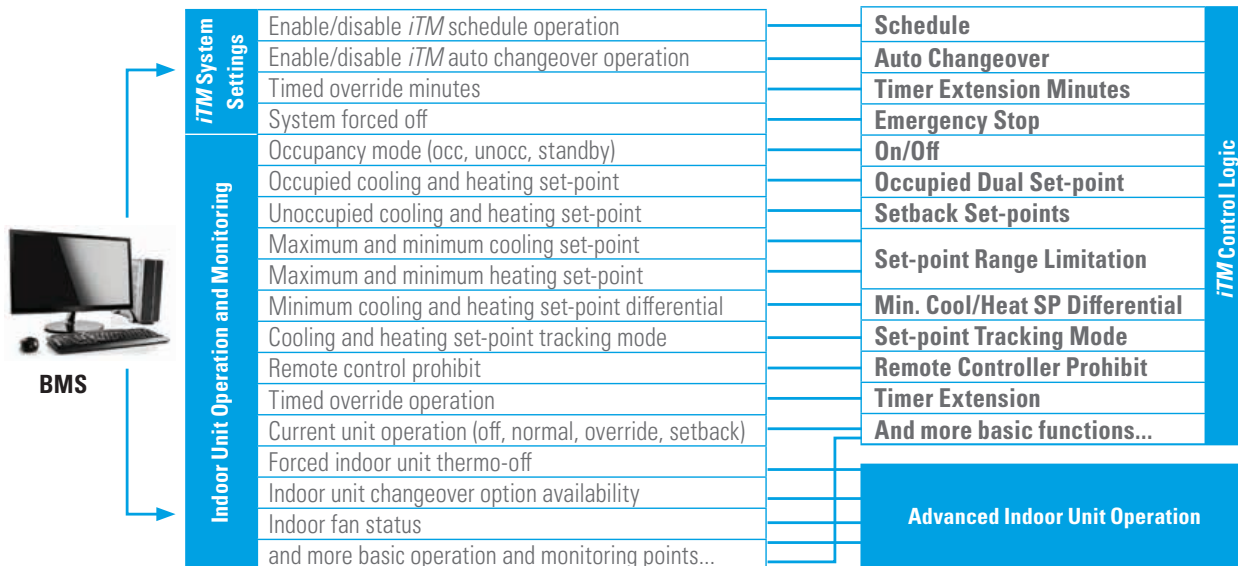

BACnet® is a trademark of ASHRAE.



## DCM007A51 - ITM Web (HTTP) Interface Option

- » Building or Home Automation Interface based on HTTP protocol
- » Interface between the DIII-Net and the HTTP automation work station.
- » Monitor and Control up to 512 Indoor units groups

## DMS502B71 - Interface for use in BACnet®

- » BACnet: Building Automation and Control Networks
  - Standard open protocol based on ANSI/ASHRAE Standard 135
- » Monitor/Control indoor unit's points
- » Monitor/Control up to 256 indoor units groups (512 indoor units)
- » Manage up to 4 DIII-Net systems
  - Option Board (DAM411B51) required

### BACnet, LonWorks and Modbus® Interface overview

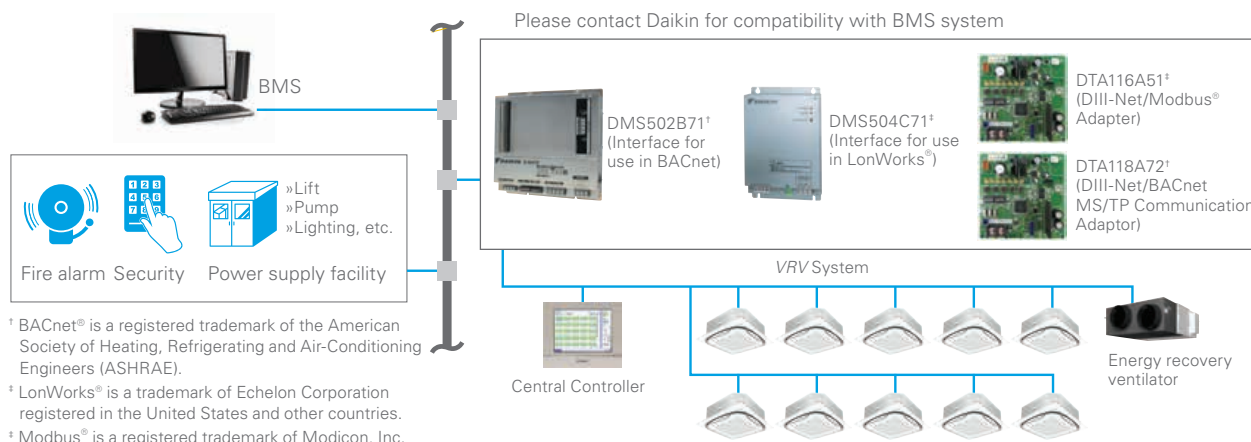

## DMS504C71 Interface for use in LonWorks®

- » BMS interface based on LonTalk
- » Interface between Daikin DIII-Net and BMS LonTalk work station
  - Manages up to 64 indoor unit groups (128 indoor units) with network variables for each group
  - Manages 1 DIII-Net system
- » Lon Interface communicates over twisted pair wire
- » External Interface File (XIF) documents device information available at [www.daikincomfort.com](http://www.daikincomfort.com)

## DTA116A51 - DIII-Net Modbus Adaptor

- » BMS interface based on Modbus (RS485)
- » Gateway between Daikin DIII-Net and BMS Modbus workstation
  - Manages up to 16 VRV indoor units connected to up to 2 outdoor units
- » Modbus interface communicates via Modbus RTU

## DTA118A72 -DIII-NET/ BACnet MSTP Communication Adaptor

- » The DIII-Net/BACnet MS/TP Communication Adaptor enables the connection of VRV systems to a compatible Building Management System (BMS).
- » The adaptor operates as a BACnet router/gateway for the VRV system.
- » With this adaptor, a third-party BMS can monitor the VRV indoor units and outdoor units, as well as control the VRV indoor units through the BACnet MS/TP protocol.
- » The adaptor can be mounted to the VRV outdoor or indoor unit.

Daikin's BACnet, LonWorks and Modbus interface units provides control for all VRV systems.



The Daikin *HERO* Simple Edge provides a connection of a Daikin *VRV*\* system to the *HERO* Cloud Services network for remote monitoring. The *HERO* Simple Edge is mounted onto the outdoor unit, and the built-in SIM card provides wireless connectivity.

Daikin *HERO* Cloud Services is a remote monitoring service for Daikin *VRV*\* systems. When integrated, data visualization of connected indoor and outdoor unit data and animated piping diagrams displaying operation status is provided. Daikin *HERO* Cloud Services also includes failure prediction for the compressors and sensors and refrigerant leak detection in the *VRV* system. In addition, *HERO* Cloud Services can help optimize the equipment operation based on outdoor ambient temperatures.

**Elevate control through remote monitoring:**

- » **Time and cost-saving opportunities** – Helps reduce unnecessary truck rolls and expand awareness of potential system issues.
- » **An owner-oriented design with a customizable dashboard** – Provides a quick overview of all connected sites and *VRV* systems.

*HERO* Cloud Services is based upon a recurring licensing fee to access site information. Licenses can be purchased in 1-year, 3-year, or 5-year increments, with no additional cost for the first-year access after the device, is activated.

\*Compatible with select Daikin *VRV* models. Please visit [daikincomfort.com](http://daikincomfort.com) to learn more.

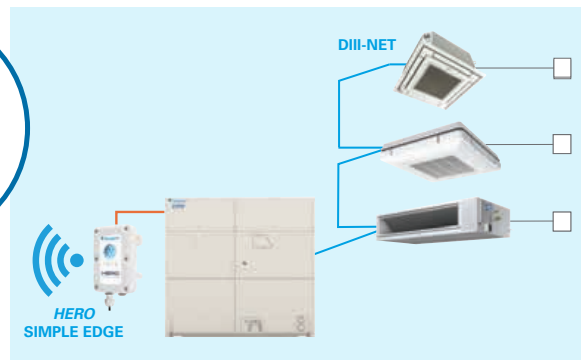
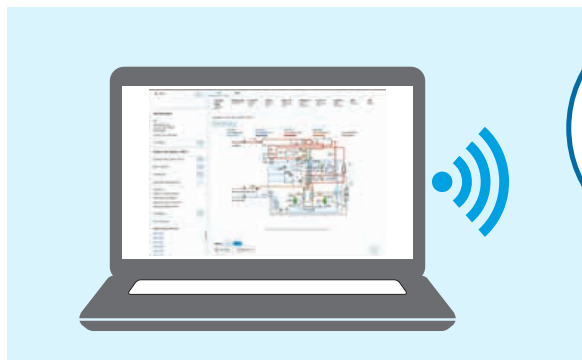



## Features and Benefits:

- » Mounts to the outdoor unit using powerful Neodymium magnets.
- » Powered by the outdoor unit and does not require separate power or panel build.
- » The built-in cellular connectivity<sup>1</sup> provides a simple connection to the cloud without burdening the building network and without the addition of expensive network gateways.
- » Connects directly to the Daikin VRV\* outdoor unit system without needing additional adaptors or centralized controllers.
- » Simple device commissioning using a QR code.



## System Capacity:

- » A maximum of the one (1) Daikin VRV\* outdoor unit system and its connected indoor units (up to 64) can be connected to the Simple Edge device.
- » Multiple Simple Edge devices can be connected on a site.
- » A single user account can monitor multiple sites.

<sup>1</sup> HERO Simple Edge uses cellphone communication. HERO Simple Edge cannot establish communication outside the service area, and it is possible, communication cannot be established even if installed within the service area but where cellphone signals are hard to reach, such as underground or on a high-rise building, etc.

\*Compatible with select Daikin VRV models. Please visit [daikincomfort.com](http://daikincomfort.com) to learn more.





Daikin HERO Pro Edge is a cloud-based VRV Centralized Controller that offers real-time remote control and monitoring, advanced analytics, and a customized dashboard. Daikin HERO Pro Edge can also control and monitor Daikin Mini-split/Multi-split, Daikin ERV (VAM), Daikin Rooftop Units, Daikin Applied Rebel, and third-party systems.

Daikin HERO Cloud Services is a remote monitoring and control service for Daikin VRV systems and other equipment connected to Daikin HERO Pro Edge. The HERO Cloud Services is based upon a recurring licensing fee to access site information. The HERO Pro Edge includes the first year HERO Cloud Services access for monitoring and control with the purchase of the hardware; licenses can be renewed in 1-year, 3-year, or 5-year increments.

### System Capacity

- » 14 Outdoor units (Expand up to 56 Outdoor units with the use of option adaptor)
- » 128 Indoor units (Expand up to 512 Indoor Units with the use of option adaptor)
- » 3 Digital Outputs and 8 Digital Inputs (Expand up to 32 Digital Inputs with the use of option adaptors)
- » 512 WAGO® Inputs and Outputs
- » 1000 Total management points
- » 50 BACnet® Devices for monitoring and control

### Software Options

- » Power Proportional Distribution (one-time license activation) (DGE002A71)
  - Calculates apportionment of outdoor unit's total power consumption to individual indoor units on the system
- » BACnet Client (One time license activation)
  - Can be purchased in 10 device (DGE009A71) or 50 device (DGE009A72) license
  - Enabling the BACnet Client option allows the Pro Edge to use the BACnet/IP protocol
  - Allows for full monitoring and control of 3rd party BACnet capable equipment
  - Up to 512 BACnet management points
- » Tenant App (one-time license activation) (HGPFETEN-01)
  - Provides remote access for tenants to their indoor units in multi-family applications

BACnet® is a trademark of ASHRAE.

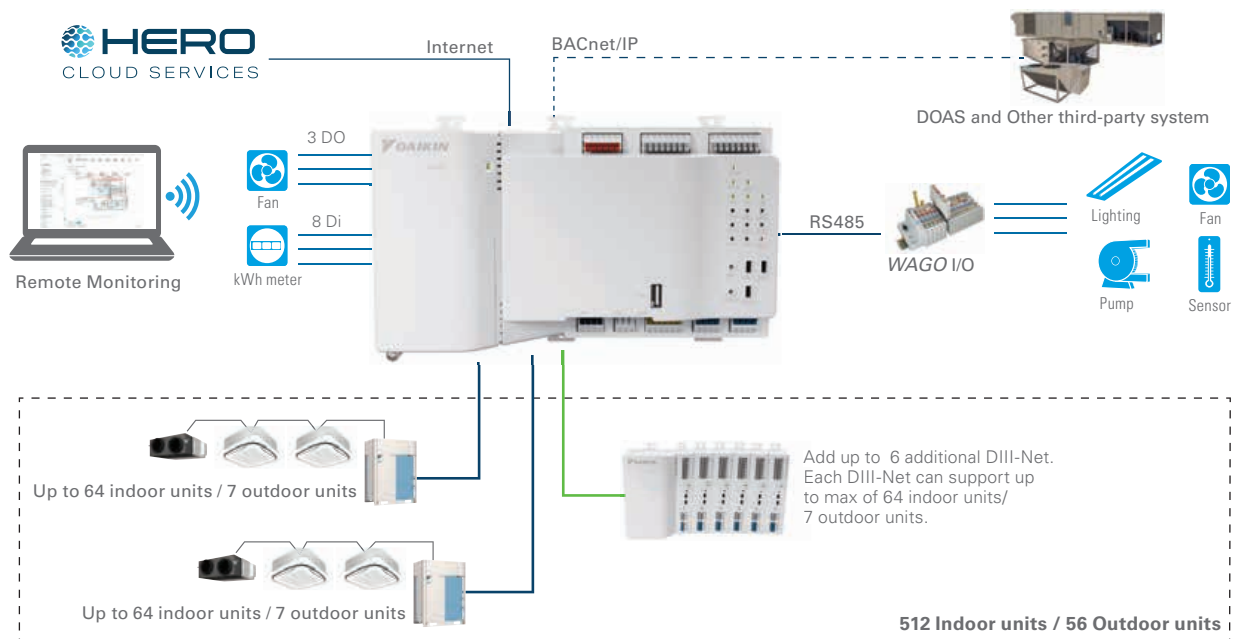

# The HERO Cloud Services and HERO Pro Edge (cont.)



## Features of HERO Cloud Services with HERO Pro Edge

- » Remote monitoring for Daikin VRV outdoor and indoor unit operation data.
- » Intuitive, customizable dashboard provides quick status of connected units and sites.
- » Animated piping diagram based on system mode of operation.
- » Download or view historical data (up to 5 years) with built-in trending capabilities.
- » Alarm dashboard with automatic email notifications when an alarm occurs.
- » The Alarm details page provides in-depth information regarding an alarm with a detailed description, possible causes, tech tips, and a comment section.
- » The Energy Management dashboard is used to view energy consumption for the outdoor units (only for Daikin VRV EMERION units).
- » User management with customizable access for the user.
- » Monitor multiple outdoor and indoor units across multiple sites with a single login.
- » Advanced scheduling with Holidays and energy-saving settings.
- » Powerful indoor unit control features such as set-point range limits, button lockouts, Setback, Auto changeover with deadband, and guard timer using Vote, Average, Individual, and Fixed methods.
- » Automatic registration of indoor units and outdoor units.
- » Tenant billing option (PPD) allows proportional billing of tenant's outdoor unit usage.
- » Control and monitor third-party equipment using WAGO® I/O
- » Control and monitor BACnet® devices such (third-party unit BACnet DDC) using the BACnet Client optional license
- » Interlock programming for automated equipment control.
- » Tenant App allows tenants in multi-family building to have individual access to their assigned indoor units via an app on their smart device.

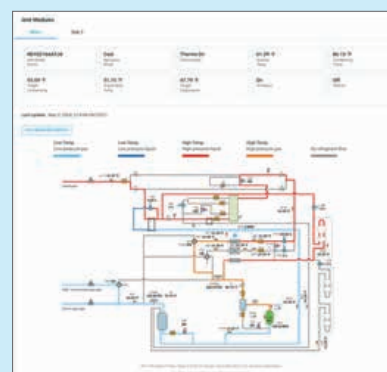
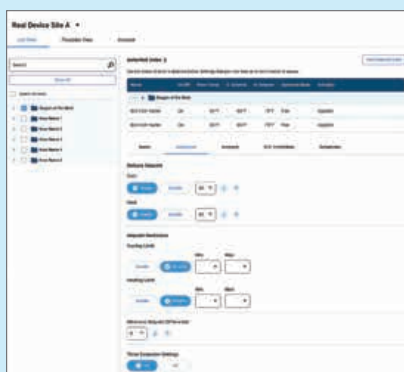

PART NUMBER	DESCRIPTION
DGE601A71	Daikin HERO Pro Edge
DGE601A72	Plus ADP for Daikin HERO Pro Edge and iTM
DGE601A53	Plus ADP Slot (For use with DGE601A72)
DGE002A71	Power Proportional Distribution (PPD) – Tennant billing
DGE009A71	Monitor up to 10 BACnet Devices
DGE009A72	Monitor up to 50 BACnet Devices
HGPFETEN-01	Allow tenant to monitor and controls assigned indoor units (no access to system data)
WAGO I/O	Monitor and control third-party units using I/O contacts.

<sup>1</sup> The power proportional distribution (PPD) feature supplies the user with a reasonably calculated apportionment of the total power consumption by the Daikin VRV system. Because input to the PPD includes measured pulses in the refrigerant system and because the VRV system includes a number of variables, including the operating temperatures and pressures, piping lengths, heat exchange rates, and so forth, no meter-type apportionment of individual user consumption can be made. However, the PPD feature provides an apportionment methodology that uses highly advanced technology and is applied to the many variables in the VRV system.

BACnet® is a trademark of ASHRAE.

Daikin *HERO* Cloud Services is a remote monitoring and system control service for Daikin *HVAC* systems and ancillary equipment. When integrated, data visualization of connected HVAC equipment and animated piping diagrams displays operation status. Daikin *HERO* Cloud Services also includes failure prediction for the compressors and refrigerant leak detection in the Daikin *VRV* System.

**Elevate control through remote monitoring:**

» **Time and cost-saving opportunities** – Helps reduce unnecessary truck rolls and expand awareness of potential system issues.

» **An owner-oriented design with a customizable dashboard** – Provides a quick overview of all connected sites and Daikin *VRV* systems.

Daikin *HERO* Cloud Services is based upon a recurring licensing fee to access site information. Licenses can be purchased in 1-year, 3-year, or 5-year increments, with no additional cost for the first-year access after the device is activated.

\* Compatible with select Daikin *VRV* models.  
Please visit [daikincomfort.com](http://daikincomfort.com) to learn more.

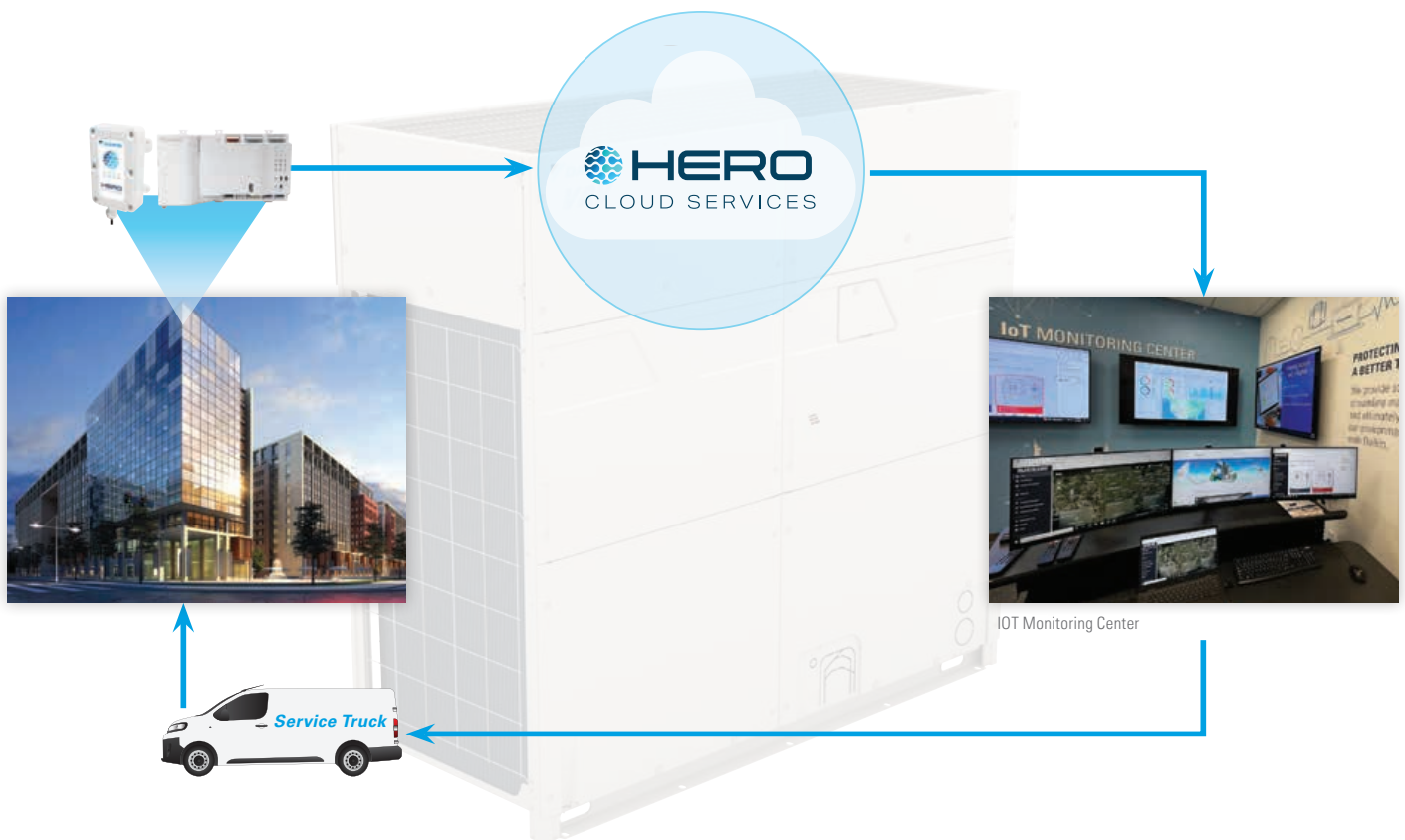

# The Daikin HERO Cloud Services (cont.)



- » Remote monitoring to help manage and diagnose system performance.
- » Uses predictive logic to notify of impending failures.
- » Visualize system performance through the integrated dashboard from a web browser or the Daikin HERO Cloud Services App.
- » Streamline service and maintenance for each site.
- » The Daikin HERO Simple Edge offers a secure cellular communication to the Daikin HERO Cloud Services use a built-in SIM card.

- » The Daikin HERO Pro Edge allows connecting to Daikin HERO Cloud Services by using the building internet (Ethernet) connection or use an optional LTE router for network free communication.

Daikin HERO Cloud Services license options: 1-year, 3-year, and 5-year licenses. Learn more at [www.daikinhero.com](http://www.daikinhero.com)

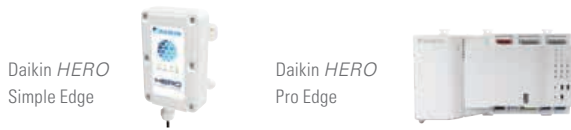

## The Daikin HERO Cloud Services benefits include advantages for building owners, contractors, and Daikin representatives:

### Building Owners

- » Peace of mind
- » Remote monitoring and control
- » Multi-site access
- » Intuitive user interface

### Daikin Representatives

- » Remote access to all buildings in your territory
- » Continuous commissioning
- » Provide a service solution to the end-user
- » Commissioning reports, maintenance check and system health check

### Contractors

- » Remotely diagnose technical issues
- » Easy troubleshooting using multiple tools, live data, graphs, history trends, alarm console, etc
- » Error prediction and notifications



Remote monitoring and control anytime, from anywhere

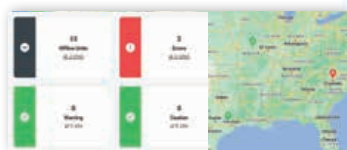

Multi-site access and map view



Energy Savings

- **Monitor and control** your building no matter where you are
- **Manage multiple sites**
- **Visualize energy consumption and benchmark** between different sites to help reduce energy costs
- **Remote diagnostic support** to help increase your systems lifetime
- **Predictive maintenance** to help prevent breakdowns
- **Remote troubleshooting** in case of malfunctions



Trending and report generation

Remote alarms for pre-diagnostics with unique predictive logic



Optimization recommendation by Daikin experts



The Daikin HERO Cloud Services dashboard offers an overview of the accessible sites and provides the status of the total number of units displaying alarms, errors, warnings, or offline. The dashboard can be customized using the “Customize” button on the top right side of the page to fit the user’s role. The Customize button allows users to add or remove the widgets (Map, Subscription, and Energy management). For example:

» The License widget will display the currently subscribed sites and the expiration date.

» The “Energy Management” widget offers customized bar chart views for the energy consumption of the selected unit. This widget will also give users a quick view of their site’s outdoor unit and indoor unit error status and mode of operation.

On the top right of the dashboard, users can switch to dark mode, check the current errors through the notification icon, request site access control through the “key icon,” and edit the user profile.



## Individual Controllers

ITEM	MODEL NO.	FUNCTION
Navigation Remote Controller	BRC1NRV71/72 (R-410A), (R-32) <b>R32</b>	Programmable zone controller
DKN Cloud Wi-Fi Adaptor	AZAI6WSDCKA	Remote control by smartphone app
Wireless Remote Controller	BRC4C82 BRC7E818 BRC7E83 BRC082A41W BRC082A42S BRC082A42W	Hand-held zone controller with infrared receiver kit
Daikin ONE+ Smart Thermostat	DTST-CWBSA-NI-B	Smart thermostat with App control
Madoka Remote Controller	BRC1H71W	Compact controller with Bluetooth® setup App
Daikin ONETouch	DTST-TOU-A	Smart thermostat with App control

## Multi-Zone Controllers and Options

ITEM	MODEL NO.	FUNCTION	
intelligent Touch Manager (iTM)	intelligent Touch Manager (iTM)	DCM601B71 Air-conditioning management system that can be controlled by touch screen or web browser to monitor and control up to 64 groups (10 outdoor units)	
	HERO Pro Edge DIII Plus Adaptor / HERO Pro Edge DIII Plus ADP Slot	DGM601A72/ DGE601A53 Up to 7 Plus adaptors can be connected to the iTM. Up to 6 Plus adaptors can be connected to the HERO Pro Edge. Each Plus Adaptor can add up to 64 additional groups (10 outdoor units)	
	iTM PPD Option	DCM002A71 Power consumption of indoor units are calculated based on operation status of the indoor unit and outdoor unit power consumption measured by kWh meter	
	iTM Web (HTTP) Interface Option	DCM007A51 The iTM Web IF (HTTP) software provides a building automation system or a home automation system the ability to monitor and control the VRV/indoor units over the HTTP protocol.	
	iTM BACnet® Client Option	DCM009A51 The BACnet Client Option enables the iTM to control and monitor equipment through the BACnet/IP protocol	
	iTM BACnet Server Gateway Option*	DCM014A51 The BACnet Server Gateway Option provide BMS integrators with the ability to monitor and control the VRV/indoor units via the BACnet/IP protocol.	
Daikin HERO Pro Edge	HERO Pro Edge	DGE601A71 Air-conditioning management system that can be controlled by the HERO Cloud to monitor and control up to 64 groups (7 outdoor units)	
	HERO Pro Edge DIII Plus Adaptors	DGE601A72/ DGE601A53 Up to 6 Plus adaptors can be connected to the Hero Pro Edge. Up to 5 DGE601A53 can be used with the DGE601A72 when combined with the HERO Pro Edge	
	HERO Pro Edge (PPD)	DCM601B71 Power consumption of indoor units are calculated based on operation status of the indoor unit and outdoor unit. The power consumption measured by kWh meter	
	HERO Pro Edge BACnet IP Client	DGE009A71	The BACnet Client Option enables the HERO Pro Edge to control and monitor equipment through the BACnet/IP protocol (Up to 10 BACnet Devices)
		DGE009A72	The BACnet Client Option enables the HERO Pro Edge to control and monitor equipment through the BACnet/IP protocol (Up to 50 BACnet Devices)
	HERO Tenant App	HGPFETEN-01 Allow tenant to monitor and controls assigned indoor units	

\*iTM BACnet Server Gateway Option is not compatible with iTM BACnet Client option.

## Hardware Interface Solutions

ITEM	MODEL NO.	FUNCTION
DKN Plus Interface	AZAI6WSPDKC	Third-party thermostat/HAS integration through cloud, Modbus®, BACnet MS/TP, or G/Y/W connection
Interface for use in BACnet	DMS502B71	Interface unit to allow communications between VRV and BMS. Operation and monitoring of air-conditioning systems through BACnet/IP communication.
Optional DIII board	DAM411B51	Expansion kit, installed on DMS502B71, to provide 2 more DIII-NET communication ports. Not usable independently.
Interface for use in LonWorks®	DMS504C71	Interface unit to allow communications between VRV and BMS. Operation and monitoring of air-conditioning systems through LonWorks communication
Interface for use in Modbus®	DTA116A51	Use of the Modbus protocol enables the connection of the VRV system with a variety of home automation and BMS systems from other manufacturers.
DIII-Net/BACnet MS/TP Communication Adaptor	DTA118A72	Interface unit to allow communications between VRV and BMS. Operation and monitoring of air-conditioning systems through BACnet/MSTP communication.

BACnet® is a trademark of ASHRAE.

## Adaptors

ITEM	MODEL NO.	FUNCTION
DIII-Net Expander Adaptor	DTA109A51	Apply to increase the number of outdoor units (up to another 10) connected in one DIII-Net system. Apply to overcome communication errors in electrically noisy environments.
External control Adaptor for Outdoor Unit	DTA104A53/61/62	Unified changeover of Cool/Heat mode. To change the mode of several outdoor units by one remote controller. Demand Control. Low Noise Control: -2 to 3 dB of outdoor unit
Group Control Adaptor	KRP4A71/72/73/74	Turn On/Off Remote Control Group. Change set-point (with resistance interface 0-135 ohm). Monitor On/Off and Error status
ABC Terminal Kit	BRP2A81	Remotely manage the operating mode of the heat pump system. Integration point for ambient thermostats to engage lock-out. BRP Adaptor and Button sensor.
Wiring Adaptor	KPR1C74/75/76/77	Thermo-on status. Fan status. AUX heater output. Humidifier output
RA Interface Adaptor for DIII-Net Use	KRP928BB2S	Mini-split can be controlled through DIII-NET
RA PCB Adaptor for Time Clock	KRP413A1S	Remotely Start / Stop for mini-split indoor units

## WAGO® I/O System

MODULE	PART NUMBER	DESCRIPTION	
Basic Kit	60359653	Bus Coupler, Connector, 24 VDC Power Supply, and End Module	
Digital Input	2 Channel DI	750-400	2 Channel Digital Input Module, 24 VDC
	4 Channel DI	750-432	4 Channel Digital Input Module, 24 VDC
	8 Channel DI	750-430	8 Channel Digital Input Module, 24 VDC
Digital Output	2 Channel DO	750-513/000-001	2 Channel Digital Output Module, without power jumper
	4 Channel DO	750-504	4 Channel Digital Output Module, 24 VDC
Analog Input	2 Channel AI	750-454	2 Channel Analog Input Module, 4-20 mA, Differential Inputs
		750-479	2 Channel Analog Input Module, ± 10 VDC, Differential Measurement Input
		750-461/020-000	2 Channel Analog Input Module, NTC 20k Ohm
	4 Channel AI	750-455	4 Channel Analog Input Module, 4-20 mA, single-ended
		750-459	4 Channel Analog Input Module, 0-10 VDC, single-ended
Analog Output	2 Channel AO	750-554	2 Channel Analog Output Module, 4-20 mA
		750-550	2 Channel Analog Output Module, 0-10 VDC
	4 Channel AO	750-555	4 Channel Analog Output Module, 4-20 mA
		750-559	4 Channel Analog Output Module, 0-10 VDC
Internal System Power Supply	750-613	24 VDC Bus Power Supply Module, Required for use after every 32 contact points connected in a node	
Passive Power Supply	750-602	24 VDC Power Supply Module, passive	
24 VDC Jumper	750-603	24 VDC Power Jumper Module, for use with 8 channel DI module	





# Support and Tools



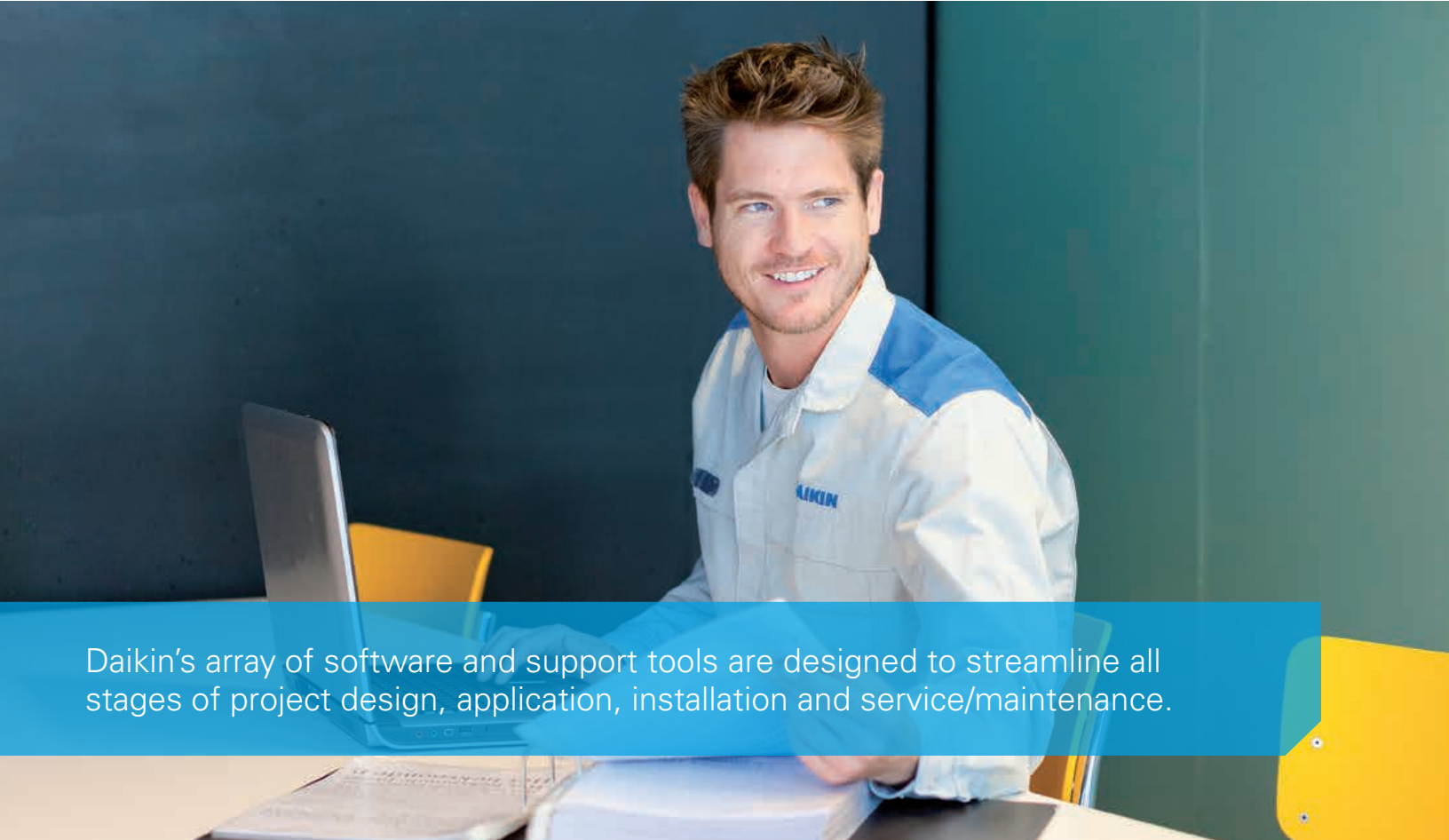









Daikin's array of software and support tools are designed to streamline all stages of project design, application, installation and service/maintenance.

Daikin provides multiple tools to aid the design, selection, analysis, submission, and general support for its line up of ductless, rooftop, light commercial split and specifically for the full line of Daikin *VRV* systems.

The tools have been designed to be simple to use, easily accessible and to address the various considerations and steps in the evolution of a residential or commercial project, aimed at helping the architect, consulting engineer, contractor, installation technician, and service company to enhance workflows and general project execution.

## Daikin VRV support and tools overview

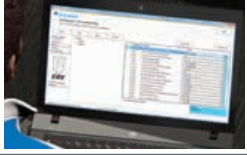
CATEGORIES		TOOLS													
		WebXpress	Ventilation Xpress	Controls Configurator	Online Energy Calculator	IES-VE Daikin VRV plug-in	Performance curves for third-party energy simulation Programs	CAD drawings	Revit models	Reference Charge Calculator	Ventilation Rate Calculator	Daikin City (including Guide Specs, IOMS etc.)	VRV Configurator	Service Checker	Online Spare Parts Bank
	Selection		■	■	■										
	Energy screening and simulation					■	■	■							
	Design and verification							■	■	■	■				
	Online and tablet reference (spec, data, submittal)											■			
	After sales and service												■	■	■

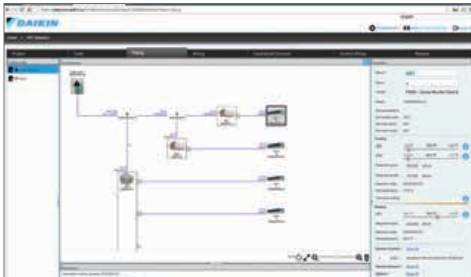

WebXpress



IES-VE plug-in for Daikin VRV



## Selection software

A key tool for Reps, Consulting Engineers and Contractors to use is the suite of **Xpress** selection software. These tools are web based and windows based EXE file designed to provide quick, easy and above all accurate selections of VRV systems and ventilation devices. Inputs can be customized to meet a variety of project needs and has the following features and benefits:

- » Fully array of software configuration settings
- » Select and customize indoor unit types with options/accessories
- » Optimize condensing unit selections based on block load characteristics
- » Define pipe sizes and lengths and both local and centralized wiring schemes
- » Define and generate selection reports in Word (DOC), Excel (XLS), or CAD (DXF) formats

As controls for variable refrigerant flow system systems become much more sophisticated at both a zone and building level, ensuring the full array of features are captured, Daikin has developed a simple **controls configurator tool** allowing the consulting engineer or contractor to capture all of the features that are needed to be utilized with the suite of controls products from Daikin so to ensure that the commissioning engineer can then set-up and configure the system appropriately at start up.



## Energy screening and simulation tools

With the continued trend in looking at building costs beyond just the 1<sup>st</sup> cost, accurately screening or simulating the performance of systems in buildings at the conceptual stage is more important than ever. Daikin recognizes this need and has developed a variety of support tools for this purpose.

### Online VRV energy calculator

- » Easy access and registration via online.
- » Free of charge and easy to use.
- » Allows for a semi-dynamic energy screening to be completed for VRV only. Provides useful information such as part load curves, estimated annualized operating costs etc.

### IES-VE plug-in for Daikin VRV

- » One of the leading Energy Simulation programs in Europe is now gaining awareness and a growing user-base in North America.
- » With the Daikin VRV plug in for IES-VE you can take advantage of the enhanced energy simulation capabilities with the IES platform and combine in a fully validated modeling methodology for Daikin VRV systems including the innovative and energy saving "VRT" function. The results of the IES-VE simulations can be utilized for LEED®, California Title 24 and other regulatory energy simulation requirements.

### Performance curve/plug-ins for 3rd party modeling software

- » Daikin have developed curves, instructions and sample building files for a variety of other 3rd party energy simulation software programs such as:
  - eQuest
  - Energy Pro
  - Trace 700
  - Energy Plus (VRV HP only)
  - HAP

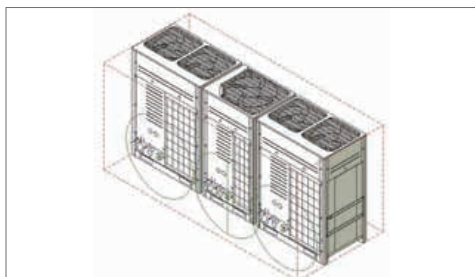

Revit



## Design and verification

Equipment Selection and Energy Simulation only reflect the early stages of a project evolution. At Daikin we recognize the importance of additionally providing resources to the Engineer and Architect community as well as contractors as follows:

- » **CAD** files for all products in multiple formats (DWG and DXF), etc.
- » **Revit** files for BIM architecture for all products
- » **Refrigerant Charge Calculator**
  - Quick check of the total refrigerant charge in a VRV System based on applied pipe-lengths and combination ratio's etc
  - Quick check of the minimum room volume (occupied space) that system charge can be utilized in per ASHRAE Standard 15-2010 and ASHRAE Standard 34-2010.
- » **Ventilation Rate Calculator**
  - Easy to use calculator to determine ventilation rates required for different room sizes and applications in accordance with ASHRAE Standard 62.1-2013.



www.daikincity.com



## Online and tablet reference material

**Daikin City** serves as the multi-functional portal for all disciplines interested in or already using Daikin products and technologies for a project. More than just a typical website, Daikin City provides:

- » Energy-saving characteristics of VRV systems in various vertical market buildings
- » Product videos and feature summaries via the communications center
- » A fully stocked library of information simply arranged for ease of finding any piece of Daikin information you may need such as IOM's, brochures, engineering data, and application guides etc (registration required).
- » Easy access to the suite of sales tools that Daikin offer (registration required).
- » An easy to use product specification library to quickly verify any spec item required, or to generate a submittal data sheet, guide spec or confirmation of the available accessories and options for a specific product (registration required).



Get Instant Product Info and Support—Anywhere, Anytime.

With the new Daikin **TECH HUB** app, essential technical and service information can be at your fingertips — helping you troubleshoot, service, and support Daikin, Amana® Brand, and Goodman equipment with confidence and speed.

App is available in three languages: English, French, and Spanish



SCAN THE QR CODE OR VISIT [WWW.DAIKINCOMFORT.COM](http://WWW.DAIKINCOMFORT.COM) TO LEARN MORE AND WATCH EXCLUSIVE DAIKIN **TECH HUB** APP VIDEOS!

App Store is a registered trademark of Apple Inc. Google Play and the Google Play logo are trademarks of Google LLC.





Daikin VRV Configurator



Daikin's online spare parts databank



## After sales and service

With a strong commitment to sales tools to help design and apply the product is equally supported with a strong commitment on after-sales and service tools aimed at the service contractor or maintenance technician.

- » **Daikin VRV Configurator** is a PC based software tool that allows an installing contractor to “set-up” the operating parameters and field settings of the VRV IV outdoor units off-site and then use a handy USB connection to upload those settings during the commissioning process. This helps save time and ensure that projects with multiple systems can be set up correctly and error free. The Configurator tool also allows for up to 48hrs of operation data from an installed system to be downloaded to a laptop computer for analysis if needed.
- » **Daikin VRV Service Checker** is a PC based software tool that facilitates a connection to the system and monitors all components of the system including temperatures, pressures, compressor and fan speeds, and may other items and can be utilized to understand operational trends with the system and what is happening in the system at a specific

time. This tool is very helpful when troubleshooting a system in the event of error or diagnostic notification.

- » **Daikin's online spare parts databank** (registration required) is an easy to use graphically driven means of identifying what spare or replacement part might be needed during the life cycle of the VRV equipment. Using this resource will help you identify the part number, applicable model, any alternative part options, and the availability of the part both locally and globally.
- » **Daikin University** offers Daikin's customers a variety of quality training programs designed to provide the tools and resources needed for our customers to be successful.
  - Our courses are designed by training professionals around specific objectives based on industry needs and job task analysis. We offer a choice of instructional settings based on the program goals and our students' needs including: online/on-demand web-based training, instructor led webinars, on-site training, and instructor-led classroom training at one of our many Daikin Authorized training facilities.

## Notes

---

---

---

---

---

---

---

---

---

---

---

---

---

---

---

---

---

---

---

---

---

---

---

---

---

---

---

---

---





# Notes

---

---

---

---

---

---

---

---

---

---

---

---

---

---

---

---

---

---

---

---

---

---

---

---

---

---

---

---

---





## About Daikin:

Daikin Industries, Ltd. (DIL) is a Fortune 1,000 company with more than 100,000 employees worldwide and a leading indoor comfort solutions provider. Daikin Comfort Technologies North America, Inc. (DNA) is a subsidiary of DIL, providing Daikin, Goodman, Amana Brand, and Quietflex brand products. DNA and its affiliates manufacture heating and cooling systems for residential, commercial, and industrial use that are sold via independent HVAC contractors. DNA engineering and manufacturing is headquartered at Daikin Texas Technology Park near Houston, TX. For additional information, visit [www.daikincomfort.com](http://www.daikincomfort.com).



### ADDITIONAL INFORMATION

Before purchasing this appliance, read important information about its estimated annual energy consumption, yearly operating cost, or energy efficiency rating that is available from your retailer.

Our continuing commitment to quality products may mean a change in specifications without notice.

© 2026 DAIKIN COMFORT TECHNOLOGIES NORTH AMERICA, INC.

Houston, Texas · USA · [www.daikincomfort.com](http://www.daikincomfort.com)

® / TM 2026 Amana. Manufactured under license by Daikin Comfort Technologies North America, Inc., Limited warranty provided by the manufacturer.

CT-VRV\_02-26